



**DAVIES,
CRAIG** PTY. LTD.

INNOVATION - QUALITY - RANGE

Electric Water Pumps

EWP ELECTRIC
WATER PUMP
Replaces belt-driven water pumps



Electric Booster Pumps
Digital Controller
EWP® Header Adaptor Kits
Thermatic® Switches
Low Coolant Alarm

2
YEAR
WARRANTY



Australian Made





Replaces belt-driven water pumps

Product Selection Guide

Application	Pump Model	Pump Kit		Pump Combo		Controller / Switch	
		Part # 12 V	Part # 24 V	Part# 12 V	Part # 24 V	Part # 12 V	Part # 24 V
Motorbike up to 500cc (Standard)	EBP®15	9001				0444 or 0455	
Motorbike 500cc - 1000cc (Std)	EBP®23	9050				0444 or 0455	
Motorbike 1000cc - 2000cc (Std)	EBP®25	9005				0444 or 0455	
Vehicle Heater System (Standard)	EBP®23	9050				0444 or 0455	
LPG (Butane) System (Standard)	EBP®23	9050				0444 or 0455	
Intercooler (depending on capacity)	EBP®23	9050					
	EBP®25	9005					
	EBP®40	9040	9041			0444 or 0455	0444 or 0455
	EWP®80	8005		8807			
Engines up to 2.0L (Standard)	EWP®80	8005		8807		8000	8000
Engines up to 2.0L - 3.5L (Standard)	EWP®115	8025 or 8040	8026 or 8041	8830 or 8850	8831 or 8851	8000	8000
Engines up to 3.5L - 5.0L (Standard)	EWP®130	8080	8081	8890	8891	8000	8000
Engines 5.0L or greater (Standard)	EWP®150	8060	8061	8870	8871	8000	8000
Modified Engines Supercharged/Turbo	EWP®150	8060	8061	8870	8871	8000	8000
Drag Racing, Drifting & Speedway	EWP®150	8060	8061	8870	8871	8000	8000
Off Road / 4WDs	EWP®130	8080	8081	8890	8891	8000	8000
Solar Hot Water Systems (depending on size)	EBP®15	9001				0444 or 0455	
	EBP®23	9050				0444 or 0455	
	EBP®25	9005				0444 or 0455	
	EBP®40	9040	9041			0444 or 0455	0444 or 0455



Pump Summary

Pump Model		At a glance				Page	
		Operating Voltage	Max. Current	Max Flow Rate	Operating Temperature		
EWP®150		12 Volt (#8060)	3 V - 15 V DC	10 Amps	150 L/min 39.63 US gal/min	-40° - 130° C -40° - 266° F	9
		24 Volt (#8061)	20 V - 27 V DC	5.5 Amps	150 L/min 39.63 US gal/min		
EWP®130		12 Volt (#8080)	3 V - 15 V DC	10 Amps	130 L/min 34.34 US gal/min	-40° - 130° C -40° - 266° F	11
		24 Volt (#8081)	20 V - 27 V DC	5,5 Amps	130 L/min 34.34 US gal/min		
EWP®115 Alloy or Nylon	 ALLOY	12 Volt (#8040)	3 V - 15 V DC	10 Amps	115 L/min 30.38 US gal/min	-40° - 130° C -40° - 266° F	13
		24 Volt (#8041)	20 V - 27 V DC	5.5 Amps	115 L/min 30.38 US gal/min		
	 NYLON	12 Volt (#8025)	3 V - 15 V DC	10 Amps	115 L/min 30.38 US gal/min	-40° - 130° C -40° - 266° F	15
		24 Volt (#8026)	20 V - 27 V DC	5.5 Amps	115 L/min 30.38 US gal/min		
EWP®80		12 Volt (#8005)	3 V - 15 V DC	7.5 Amps	80 L/min 21.13 US gal/min	-40° - 130° C -40° - 266° F	17
EBP®40		12 Volt (#9040)	9 V - 15 V DC	4.6 Amps	40 L/min 10.5 US gal/min	-40° - 120° C -40° - 248° F	18
		24 Volt (#9041)	20 V - 27 DC	2.5 Amps	40 L/min 10.5 US gal/min	-40° - 120° C -40° - 248° F	
EBP®25		12 Volt (#9005)	9 V - 15 V DC	3.5 Amps	25 L/min 6.6 US gal/min	-40° - 120° C -40° - 248° F	19
EBP®23		12 Volt (#9050)	9 V - 15 V DC	1.3 Amp	23 L/min 6 US gal/min	-40° - 120° C -40° - 248° F	20
EBP®15		12 Volt (#9001)	9 V - 15 V DC	1.3 Amp	15 L/min 4 US gal/min	-40° - 120° C -40° - 248° F	21

EWP[®] ELECTRIC WATER PUMP

Replaces belt-driven water pumps

The revolutionary range of Davies, Craig's patented Electric Water Pumps are unique performance enhancement accessories suitable for most makes of 12V and 24V engines.

There are four models available:

- EWP[®]80 – 80 litres [21.13 US gal] per minute: suitable for engines up to 2.0L (2000cc)
- EWP[®]115 – 115 litres [30.38 US gal] per minute: for engines 2.0L to 3.5L (2000cc to 3500cc)
- EWP[®]130 – 130 litres [34.34 US gal] per minute: recommended as a replacement for the EWP[®]80 and for engines 3.5L to 5.0L (3500cc to 5000cc) and 4WDs
- EWP[®]150 – 150 litres [39.63 US gal] per minute: to satisfy those larger and higher horsepower, turbocharged, supercharged and 'worked' engines which develop excessive heat that must be tamed!

The EWP[®] is designed to replace a vehicle's existing mechanical belt-driven water pump. All models are simple, fit-it-yourself electric water pumps – lightweight, compact, more powerful design suitable for small, medium, large, plus high-performance cars and 4WD vehicles. The EWPs are vital performance enhancement products that improve engine cooling management while giving more power and torque and evenly dissipating heat soak.

All deliver 3% to 5% improved fuel economy while lowering environmental impact by reducing emissions.

The EWPs are ideal as a 'booster' for your current mechanical pump within your existing cooling system.

Options for pump control

1. Use in conjunction with LCD EWP[®]/Fan Digital Controller

The Digital Controller has a micro-processor which will run the EWP[®] at exactly the right flow rate maintaining your set, targeted engine temperature.

2. Use in conjunction with a Thematic[®] Switch Combine the EWP[®] with an adjustable Thematic[®] Switch to add a cooling boost to an overheating mechanical pump cooling system.

3. Continuous Running

Wire the pump to the ignition for maximum cooling – suitable for race vehicles, very hot climates and chronically overheating engines.

Electric Water Pump Kits are supplied with everything you need for DIY installation, including easy-to-understand instructions.

4. The LCD EWP[®]/Fan Digital Controller is supplied in "Combo Kits" (see pages 8, 10, 12, 14 and 16) or can be purchased separately (see page 7).

5. Thematic[®] Switches are sold separately – see pages 22-23 for details.



EWP[®]150, EWP[®]130,
EWP[®]115 (Alloy and Nylon)
and EWP[®]80

Questions? Please see "frequently-asked questions" on our website: www.daviescraig.com.au

The many benefits of the EWP[®] include:

- increased power and torque
- increased cooling capability
- eliminating heat soak
- better control of engine temperature
- flexible options for pump control.

There are four Electric Booster Pumps (EBP®) to choose to suit your specific requirements.

EBPs are robustly constructed brushless, high-flow, magnetically-driven booster pumps. The EBP® series of brushless motor-powered booster pumps have fewer moving parts and the impellor floats in the liquid being pumped! The booster pump's internal chamber is hermetically sealed for trouble-free operation and long life.

Our EBP® are lightweight, robust, fully-sealed units. Installation can be carried out with ease. Low-current draw, high-flow capacity and long life make these EBP® ideal for a range of automotive, motorcycle, intercooler, marine and solar applications to name a few.

The EBP® kits (part #9001 and #9050) includes the EBP®15 and all accessories needed to fit it to the engine's heater hose to boost coolant flow, including easy to understand, do-it-yourself fitting instructions.

EBP®40 is available in 12V (#9040) and 24V (#9041) which includes the wiring loom and mounting bracket.

EBP®25 is available as a Kit, (#9005) which includes the wiring loom; "Short" (#9105) includes the pump only.

EBP®23 is available as a Kit (#9050), "Short" (#9051) which includes the wiring loom and mounting bracket.

EBP®15 is available as a Kit (#9001), "Short" (#9002).

See pages 18-21 for full details.



EBP®40



EBP®25



EBP®23

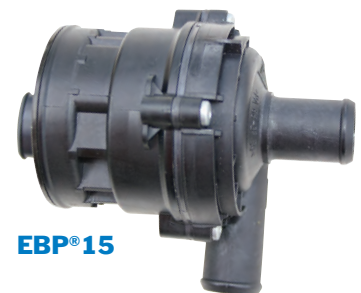

EBP®15

The many EBP® applications include:

- booster for car heater and LPG systems
- solar and marine applications
- water-cooled motorcycle and go-kart engines
- turbo air/water intercoolers
- caravans and motor homes
- household irrigation.

Questions? Please see "frequently-asked questions" on our website: www.daviescraig.com.au

EWP® Header Adaptor Kits

EWP® Header-Adaptor Kits are simply designed to complement the fitment of your EWP® Combo Kit.

If you've purchased an EWP® Combo Kit, then you will have an LCD EWP®/Fan Digital Controller with a built-in switch that will thermatically control the new electric Thematic® Fan in unison with your new EWP®.

Simple, easy-to-follow installation instructions are supplied to ensure the Davies, Craig EWP® Electric Water Pump Combo and Header

Adaptor Kit are assembled, mounted and perform in accordance with the product's design.

A video outlining the installation is also available for viewing on the Davies Craig website, www.daviescraig.com.au.

LS Series
(Part #8650) shown



EWP ELECTRIC
WATER PUMP
Replaces belt-driven water pumps

See page 24 for EWP® Header Adaptor Kit details.

LCD EWP® / Fan Digital Controller 12 Volt & 24 Volt

For optimum control of Davies, Craig 12 Volt and 24 Volt Electric Water Pumps.

Suits EWP®80, EWP®115, EWP®130, EWP®150 and Thematic® Fans.

The LCD EWP®/Fan Digital Controller has two specific functions.

This unique Digital Controller will manage the operation of the EWP® by varying the speed of the pump in response to the coolant temperature and manage control of your electric engine fan.



The Controller has a push-button to lock in any one of the nine targeted/set temperatures. It's highly recommended you set/target the Controller to closely match your engine's existing thermostat temperature.

Generally, higher engine temperature will offer improved fuel efficiency and lower engine temperature more power. The Digital Controller will operate the engine's electric fan automatically once the engine has reached 3°C (5.4°F) above the targeted (set) temperature. Another significant benefit is that the Controller allows the EWP® to run on after ignition shutdown to eliminate heat soak.

Technical Specifications

Voltage range	12V DC to 29V DC		
Display LCD size	110mm (4.33") x 80mm (3.14")		
Maximum current	12A		
Warning alarm	High & low Temp., Above set temp., Sensor short circuit, Pump error, High & low voltage and Sensor open circuit		
Targeted (set) temperatures	60°C (140°F)	65°C (150°F)	70°C (160°F)
	75°C (165°F)	80°C (175°F)	85°C (185°F)
	90°C (195°F)	95°C (205°F)	100°C (212°F)
Fan cut-in temp.	3°C (5.4°F) above the targeted (set) temperature		
Controller type	PCB with micro-processor		
Sensor type	Thermister in housing		
Overrun/shutdown	10°C (14°F) below set/target temperature or 3 minutes		
Indicators	Temperature, power, EWP, test, fan, high & low temp, voltage, above set temperature (with alarm)		
Weight	100 grams (3.5 oz)		
Dimensions	95mm (l) (3.7")	130mm (w) (5.1")	25mm (d) (1")

EWP DIGITAL CONTROLLER OPERATION

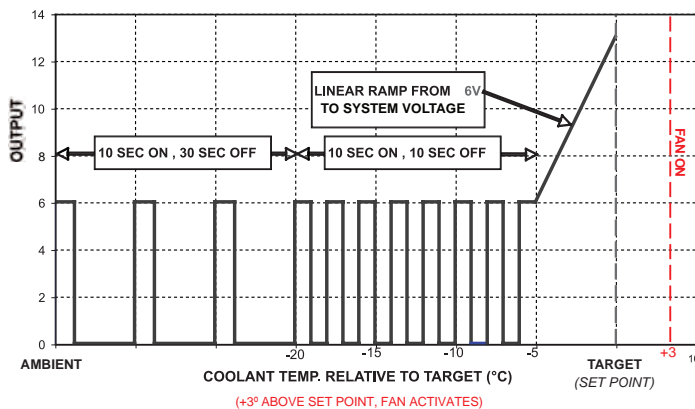

Kit Contents

Part #	Description	Qty
18000	LCD EWP®/Fan Digital Controller (only)	1
	Installation instructions	1
8411	Wiring harness	1
10415	In-line temperature sensor adaptor	1
8510	Rubber adaptor sleeve - 3mm (1/8")	2
8512	Hose clamp	2
8415	Sensor - Coolant temp. 1/4" NPT	1
	Assorted hardware	

EWP[®] 150 Alloy/Digital Controller Combo

12V - Part # 8870
24V - Part # 8871

EWP[®] 150 Alloy/Digital Controller Combo

150 Litres per minute

12 & 24 Volt

Muscle up your engine cooling system with the Davies Craig EWP[®] 150 alloy Electric Water Pump and the LCD EWP[®]/Fan Digital Controller.

Like all EWPs, this advanced unit is designed for remote mounting in the engine bay to satisfy those higher horsepower, turbocharged, supercharged and 'worked' engines which develop excessive heat.

The compact EWP[®]150 alloy unit is manufactured with AN-16 internal inlet and outlet threads for neat, tight screw-in fitting applications.

This rugged alloy hi-flow electric water pump is designed to complement or replace the engine's existing mechanical water pump. This essential performance accessory increases power to your vehicle's drive wheels and improves coolant temperature control.



The EWP[®]150 is a universal, do-it-yourself, easy installation fitment to engines up to seven litres.

By removing the parasitic power losses of belt-driven water pumps, the EWP[®]150 releases up to 10kW (1.3hp) of extra power, increased torque and fuel savings.

Combine it with the LCD EWP[®]/Fan Digital Controller and the pump continues to run after you've switched off, eliminating "heat soak" and extending engine life.

The EWP[®]150 and LCD EWP[®]/Fan Digital Controller Combo Kit is the most economical way to increase horsepower and save on fuel consumption whilst caring for your engine.

A Davies, Craig EWP[®] header adaptor kit can replace the mechanical water pump completely. See page 24.

Muscle up cooling your engine

- ✓ universal fit
- ✓ more power
- ✓ more cooling
- ✓ increase fuel efficiency
- ✓ extend engine life
- ✓ world-leading technology
- ✓ lightweight alloy



Questions? Please see "frequently-asked questions" on our website: www.daviescraig.com.au

EWP® 150 Electric Water Pump - Alloy

12V - Part # 8060
24V - Part # 8061

EWP® 150 Electric Water Pump 12 & 24 Volt



EWP 150

Kit Contents

Description	12V	24V	Qty
EWP®150 Alloy 24 Volt Pump		✓	1
EWP®150 Alloy 12 Volt Pump	✓		1
Wiring harness	✓	✓	1
Sleeve 3mm (1/8") rubber adaptors	✓	✓	2
Hose Clamps	✓	✓	2
Assorted Hardware bag includes 12 Volt relay #0533	✓		1
Assorted Hardware bag includes 24 Volt relay #0534		✓	1

Kit Options (12V & 24V)

Part #	Description	Qty
8505	90° rubber hose adaptor - 38mm (1½") ID	1*
1025	Alloy adaptor AN-16	1*
1024	Alloy swivel adaptor AN-16	1*
8511	Sleeve 6mm rubber adaptor	1*

* 2 required if using at both ends

The EWP® is a recirculating pump which is ideal for a 'closed system' similar to an automotive cooling system; it is not 'self-priming'.

The world's first universal-fit, automotive Electric Water Pump goes one better with the EWP®150.

Suitable for all makes and models - will excel on large six-cylinder engines, V8 engines, heavy duty 4WDs and most engines over 400 HP.

The EWP®150 is a practical alternative to the mechanical belt-driven pump or fitted as an auxiliary pump.

Technical Specifications

	12 Volt Pump	24 Volt Pump
Operating voltage	3V DC to 15V DC	20V DC to 27V DC
Maximum current	10A @ 13V	5.5A @ 24V
Flow rate (max)	150 L/min (39.63 US gal/min) @ 13V DC	150 L/min (39.63 US gal/min) @ 24V DC
Operating temp.	-40° to 130°C (-40° to 266°F)	-40° to 130°C (-40° to 266°F)
Pump design	Clockwise centrifugal with volute chamber	Clockwise centrifugal with volute chamber
Pump weight	1,170 grams (2.6 lb)	1,170 grams (2.6 lb)
Pump material	Aluminium (powder coated)	Aluminium (powder coated)
Burst pressure	500 kPa (72.5 psi)	500 kPa (72.5 psi)
Seal	Ceramic face seal	Ceramic face seal
Fits hose sizes	35mm to 51mm (1⅜" to 2") Internal thread - inlet: AN-16 - outlet: AN-16	35mm to 51mm (1⅜" to 2") Internal thread - inlet: AN-16 - outlet: AN-16

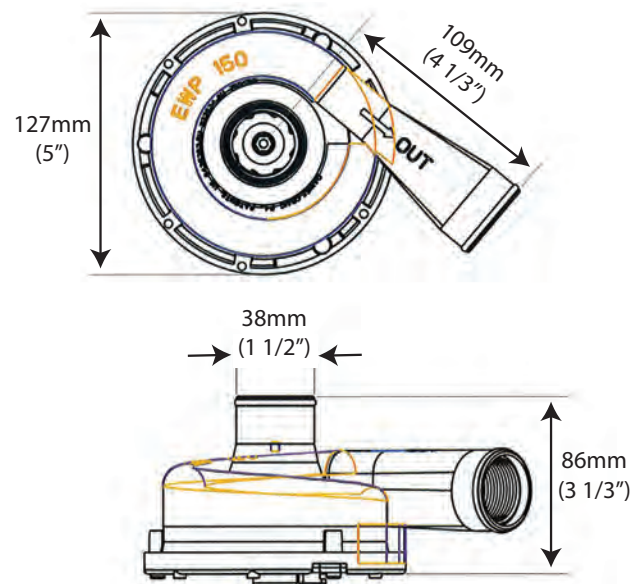

EWP® 130 Alloy/Digital Controller Combo

12V - Part # 8890

24V - Part # 8891

EWP® 130 Alloy/Digital Controller Combo

130 Litres per minute

12 & 24 Volt

Turbocharge your engine cooling with the Davies, Craig EWP® 130 alloy Electric Water Pump and your choice of Thematic® Fan and an LCD EWP®/Fan Digital Controller.

Like all the EWPs, this unit is designed for universal engine fitment, to satisfy those larger and higher horsepower, turbocharged, super-charged and 'worked' engines which develop excessive heat.

The EWP® 130 configuration mirrors the highly successful EWP® 80 which offers a numerous selection of attachment options, including elbow and straight adaptors which can be bolted on to both the inlet and outlet for simple remote engine mounting.

The EWP® 130 will be supplied with one each of the 35mm (1 3/8") straight and elbow alloy adaptors, 'O' rings and mounting hardware along with two 3mm (1/8") rubber adaptor sleeves. The respective 38 mm (1 1/2") alloy adaptors and 6mm (1/4") rubber adaptor sleeves are optional.

This rugged alloy hi-flow electric water pump is designed to complement or replace the engine's existing mechanical water pump. This essential performance accessory increases power to your vehicle's drive wheels and improves coolant temperature control.

The EWP® 130 is a universal, do-it-yourself, easy installation fitment to engines up to five litres.

EWP 130

By removing the parasitic power losses of belt-driven water pumps, the EWP® 130 releases up to 10kW (13hp) of extra power, increased torque and fuel savings.

Combine it with the LCD EWP®/Fan Digital Controller and the pump continues to run after you've switched off, eliminating "heat soak" and extending engine life.

The EWP® 130 and LCD EWP®/Fan Digital Controller Combo Kit is the most economical way to increase horsepower and save on fuel consumption whilst caring for your engine.

The Davies, Craig EWP® header adaptor kit can replace the mechanical water pump completely.

Turbocharge your engine cooling management

- ✓ universal fit
- ✓ more power
- ✓ more cooling
- ✓ increase fuel efficiency
- ✓ extend engine life
- ✓ world-leading technology
- ✓ lightweight alloy



Questions? Please see "frequently-asked questions" on our website: www.daviescraig.com.au

EWP® 130 Electric Water Pump - Alloy

12V - Part # 8080
24V - Part # 8081

EWP® 130 Electric Water Pump 12 & 24 Volt



The world's first universal fit / remote mount Electric Water Pump. Suitable for naturally-aspirated and turbo/supercharged engines up to 5 litres.



Technical Specifications

	12 Volt Pump	24 Volt Pump
Operating voltage	3V DC to 15V DC	20V DC to 27V DC
Maximum current	10A @ 13V	5.5A @ 24V
Flow rate (max)	130 L/min (34.34 US gal/min) @ 13V DC	130 L/min (34.34 US gal/min) @ 24V DC
Operating temp.	-40° to 130°C (-40° to 266°F)	-40° to 130°C (-40° to 266°F)
Pump design	Clockwise centrifugal with volute chamber	Clockwise centrifugal with volute chamber
Pump weight	1,226 grams (2.7 lb)	1,226 grams (2.7 lb)
Pump material	Aluminium (powder coated)	Aluminium (powder coated)
Burst pressure	500 kPa (72.5 psi)	500 kPa (72.5 psi)
Seal	Ceramic face seal	Ceramic face seal
Fits hose sizes	35mm to 51mm (1 3/8" to 2")	35mm to 51mm (1 3/8" to 2")

Kit Contents

Description	12V	24V	Qty
EWP®130 Alloy 24 Volt Pump		✓	1
EWP®130 Alloy 12 Volt Pump	✓		1
Alloy elbow adaptor - 35mm (1 3/8")	✓	✓	1
Alloy straight adaptor - 35mm (1 3/8")	✓	✓	2
Hose Clamps	✓	✓	2
Rubber adaptor sleeve - 3mm (1/8")	✓	✓	1
O ring	✓	✓	2
Wiring harness	✓	✓	1
Hose clamps	✓	✓	2
Assorted hardware bag - includes 12V relay #0533	✓		1
Assorted hardware bag - includes 24V relay #0534		✓	1

Kit Options (12V & 24V)

Part #	Description	Qty
8304	Alloy straight adaptor - 38mm (1 1/2")	1*
8303	Alloy elbow adaptor - 38mm (1 1/2")	1*
8505	90° rubber hose adaptor - 38mm (1 1/2") ID	1*
8511	Rubber adaptor sleeve 6mm (1/4")	1*
1025	Alloy adaptor AN-16	1*
1026	Alloy adaptor - 1 1/4" NPT	1*
1027	Alloy adaptor straight - 25mm (1")	1*
1028	Alloy adaptor straight - 19mm (3/4")	1*

* 2 required if using at both ends

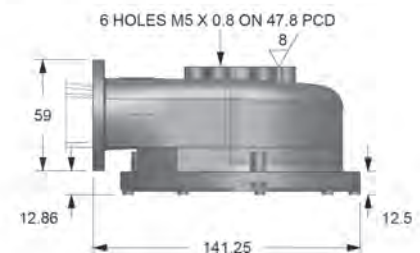
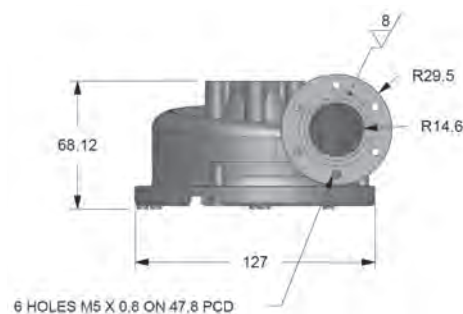

EWP® 115 Alloy/Digital Controller Combo

12V - Part # 8050
24V - Part # 8051

EWP® 115 Alloy/Digital Controller Combo

115 Litres per minute

12 & 24 Volt

Take total control of your engine cooling with the Davies Craig EWP® 115 Alloy Electric Water Pump and LCD EWP®/Fan Digital Controller. The Controller will also manage the operation of your Thermatic® Fan.

The EWP®115 (115 litres per minute) pump is suitable for small, medium, large, high-performance and 4WD vehicles. It's a performance accessory that improves engine cooling control and capacity whilst giving you more power and torque and improved fuel economy.

Mechanical belt-driven water pumps run directly off the motor and sap engine power ... the EWP®115 is hardwired into your electrical system, by-passing the engine and releasing up to an additional 10kw (13hp).

Combined with the LCD EWP®/Fan Digital Controller, the pump continues to run after you've switched off, eliminating "heat soak" and extending engine life.

Davies, Craig's revolutionary, Australian-designed EWP® pumps are made from rugged Alloy and are universal fit, allowing for easy mounting into the bottom radiator hose.

Our kits come with easy-to-understand DIY instructions and everything you need for easy installation, including different adaptors to fit various hose sizes and all necessary electrical wiring.

The EWP®115 and LCD EWP®/Fan Digital Controller Combo Pack is the most economical way to increase horsepower and save on fuel consumption whilst caring for your engine.

The Davies, Craig EWP® header adaptor kit can replace the mechanical water pump completely. See page 24.

The world's most advanced total engine cooling management

- ✓ universal fit
- ✓ more power
- ✓ more cooling
- ✓ increase fuel efficiency
- ✓ extend engine life
- ✓ world-leading technology
- ✓ lightweight alloy

Please refer opposite for EWP® specifications and page 7 for LCD EWP®/Fan Digital Controller specifications.



Questions? Please see "frequently-asked questions" on our website: www.daviescraig.com.au

EWP® 115 Electric Water Pump - Alloy

12V - Part # 8040
24V - Part # 8041

EWP® 115 Electric Water Pump 12 & 24 Volt



The world's first universal-fit, automotive Electric Water Pump. Suitable for all makes and models – will excel on large six-cylinder engines.

The EWP® 115 is a practical alternative to the mechanical belt-driven pump or fitted as an auxiliary pump.

Technical Specifications

	12 Volt Pump	24 Volt Pump
Operating voltage	3V DC to 15V DC	20V DC to 27V DC
Maximum current	10A @ 13V	5.5A @ 24V
Flow rate (max)	115 L/min (30.38 US gal/min) @ 13V DC	115 L/min (30.38 US gal/min) @ 24V DC
Operating temp.	-40° to 130°C (-40° to 266°F)	-40° to 130°C (-40° to 266°F)
Pump design	Clockwise centrifugal with volute chamber	Clockwise centrifugal with volute chamber
Pump weight	1,101 grams (2.43 lb)	1,101 grams (2.43 lb)
Pump material	Aluminium (powder coated)	Aluminium (powder coated)
Burst pressure	500 kPa (72.5 psi)	500 kPa (72.5 psi)
Seal	Ceramic face seal	Ceramic face seal
Fits hose sizes	35mm to 51mm (1 3/8" to 2") - inlet: AN-16 - outlet: AN-16	35mm to 51mm (1 3/8" to 2") - inlet: AN-16 - outlet: AN-16

Kit Contents

Description	12V	24V	Qty
EWP® 115 Alloy 24 Volt Pump		✓	1
EWP® 115 Alloy 12 Volt Pump	✓		1
Wiring harness	✓	✓	1
Rubber adaptor sleeve - 3mm (1/8")	✓	✓	2
Hose Clamps	✓	✓	2
Assorted hardware bag - includes 12V relay #0533	✓		1
Assorted hardware bag - includes 24V relay #0534		✓	1

Kit Options (12V & 24V)

Part #	Description	Qty
8505	90° rubber hose adaptor - 38mm (1 1/2") ID	1*
1025	Alloy adaptor AN-16	1*
1024	Alloy adaptor - AN-16	1*
8511	Sleeve 6mm (1/4") rubber adaptor	1*

* 2 required if using at both ends

The EWP® is a recirculating pump which is ideal for a 'closed system' similar to an automotive cooling system; it is not 'self-priming'.

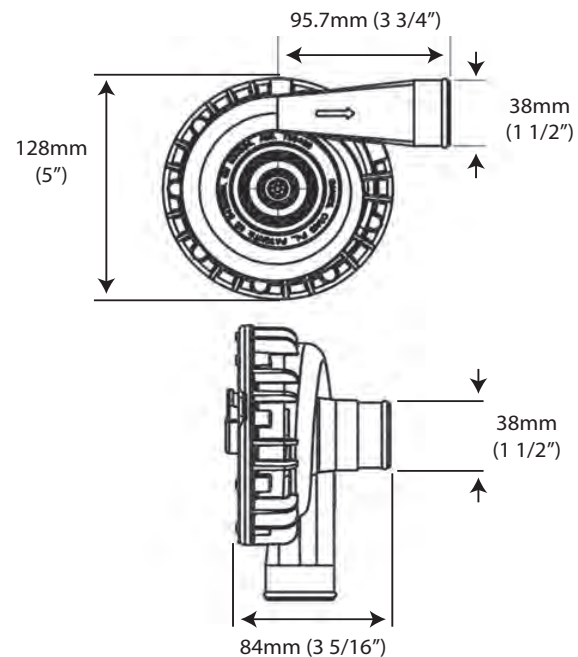

EWP® 115 Nylon/Digital Controller Combo

12V - Part # 8830
24V - Part # 8831

EWP® 115 Nylon/Digital Controller Combo

115 Litres per minute

12 & 24 Volt

Take total control of your engine cooling with the Davies Craig EWP® 115 Nylon Electric Water Pump and LCD EWP®/Fan Digital Controller. The Controller will also manage the operation of your Thermanic® Fan.

The EWP®115 (115 litres per minute) pump is suitable for small, medium, large, high-performance and 4WD vehicles. It's a performance accessory that improves engine cooling control and capacity whilst giving you more power and torque and improved fuel economy.

Mechanical belt-driven water pumps run directly off the motor and sap engine power ... the EWP®115 is hardwired into your electrical system, by-passing the engine and releasing up to an additional 10kw (13hp).

Combined with the LCD EWP®/Fan Digital Controller, the pump continues to run after you've switched off, eliminating "heat soak" and extending engine life.

Davies, Craig's revolutionary, Australian-designed EWP® pumps are made from anti-corrosive, lightweight nylon reinforced with fibreglass. Universal fit allows for easy mounting into the bottom radiator hose.

Our kits come with easy-to-understand DIY instructions and everything you need for easy installation, including different adaptors to fit various hose sizes and all necessary electrical wiring.

The EWP®115 and LCD EWP®/Fan Digital Controller Combo Pack is the most economical way to increase horsepower and save on fuel consumption whilst caring for your engine.

The Davies, Craig EWP® header adaptor kit can replace the mechanical water pump completely. See page 24.

The world's most advanced total engine cooling management

- ✓ universal fit
- ✓ more power
- ✓ more cooling
- ✓ increase fuel efficiency
- ✓ extend engine life
- ✓ world-leading technology
- ✓ lightweight Nylon

Please refer opposite for EWP® specifications and page 7 for LCD EWP®/Fan Digital Controller specifications.



Questions? Please see "frequently-asked questions" on our website: www.daviescraig.com.au

EWP® 115 Electric Water Pump - Nylon

12V - Part # 8025
24V - Part # 8026

EWP® 115 Electric Water Pump 12 & 24 Volt



The world's first universal-fit, automotive Electric Water Pump. Suitable for all makes and models – will excel on large six-cylinder engines,.

The EWP® 115 is a practical alternative to the mechanical belt-driven pump or fitted as an auxiliary pump.

Technical Specifications

	12 Volt Pump	24 Volt Pump
Operating voltage	3V DC to 15V DC	20V DC to 27V DC
Maximum current	10A @ 13V	5.5A @ 24V
Flow rate (max)	115 L/min (30.38 US gal/min) @ 13V DC	115 L/min (30.38 US gal/min) @ 24V DC
Operating temp.	-40° to 130°C (-40° to 266°F)	-40° to 130°C (-40° to 266°F)
Pump design	Clockwise centrifugal with volute chamber	Clockwise centrifugal with volute chamber
Pump weight	920 grams (2.03 lb)	920 grams (2.03 lb)
Pump material	Nylon 66 - 30% glass filled	Nylon 66 - 30% glass filled
Burst pressure	500 kPa (72.5 psi)	500 kPa (72.5 psi)
Seal	Ceramic face seal	Ceramic face seal
Fits hose sizes	35mm to 51mm (1 3/8" to 2")	35mm to 51mm (1 3/8" to 2")

Kit Contents

Description	12V	24V	Qty
EWP® 115 Nylon 24 Volt Pump		✓	1
EWP® 115 Nylon 12 Volt Pump	✓		1
Wiring harness	✓	✓	1
Rubber adaptor sleeve - 3mm (1/8")	✓	✓	2
Hose Clamps	✓	✓	2
Assorted hardware bag - includes 12V relay #0533	✓		1
Assorted hardware bag - includes 24V relay #0534		✓	1

Kit Options (12V & 24V)

Part #	Description	Qty
8505	90° rubber hose adaptor - 38mm (1 1/2") ID	1*
8511	Sleeve 6mm (1/4") rubber adaptor	1*

* 2 required if using at both ends

The EWP® is a recirculating pump which is ideal for a 'closed system' similar to an automotive cooling system; it is not 'self-priming'.

Please see pages 24-25 for EWP® header adaptors and accessories.

Please see page 26 for pressure vs flow chart.

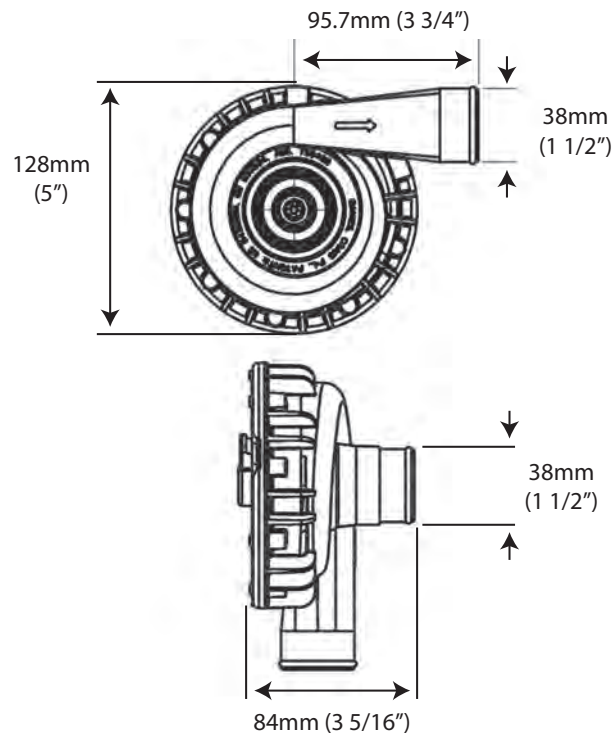

EWP® 80/Digital Controller Combo

80 Litres per minute

12 Volt only

The EWP®80 Electric Water Pump and LCD EWP®/Fan Digital Controller Combo – simple, do-it-yourself, easy to install, designed to complement or replace your existing belt-driven, mechanical water pump and engine thermostat, and operate your Thematic® Fan.

The EWP®80 will fit most vehicle makes and models fitted with naturally-aspirated or turbo engines up to two litres.

The revolutionary, Australian-designed EWP®80 is made from anti-corrosive, lightweight, heat-resistant, glass-filled nylon and incorporates a ceramic faced seal for long-life durability.

The EWP®80 greatly enhances engine cooling control while giving you added power and improved fuel economy.

By removing the parasitic power losses of a belt-driven, mechanical water pump the EWP® can provide up to 10kW (13hp) of extra power and increased torque.

The LCD EWP®/Fan Digital Controller will manage both the EWP® and Thematic® fan operation. The Digital Controller will vary the speed of the EWP® in response to the engine's coolant temperature. Multiple temperature settings are provided on the Controller for either maximum power or fuel efficiency.

The Thematic® Fan/s will be activated automatically once the engine coolant rises 3 °C (5.4 °F) above the targeted (set) temperature. The Digital Controller will automatically run on for three minutes (or to 10 °C / 14 °F below the set temperature) after engine shut down, eliminating 'heat soak' and extending engine life.

The EWP®80 Digital Controller Combo is supplied in a do-it-yourself kit with everything you need for fitment to your vehicle's engine, including an easy-to-follow DIY instruction booklet.

The world's most advanced total engine cooling management system

- ✓ universal fit
- ✓ more power
- ✓ more cooling
- ✓ increase fuel efficiency
- ✓ extend engine life
- ✓ world-leading technology
- ✓ lightweight Nylon



EWP® 80 Electric Water Pump - Nylon

Part # 8005
(12 Volt only)

EWP® 80 Electric Water Pump - Nylon 12 Volt only



Technical Specifications

	12 Volt Pump
Operating voltage	3V DC to 15V DC
Maximum current	7.5A @ 13V
Flow rate (max)	80 L/min (21.13 US gal/min) @ 13V DC
Operating temp.	-40° to 130°C (-40° to 266°F)
Pump design	Clockwise centrifugal with volute chamber
Pump weight	900 grams (2.0 lb)
Pump material	Nylon 66, 30% glass-filled
Burst pressure	350 kPa (50 psi)
Seal	Ceramic face seal
Fits hose sizes	32mm to 51mm (1 3/8" to 2")

Please see pages 24-25 for EWP® header adaptors and accessories.
Please see page 26 for pressure vs flow chart.

The world's first universal-fit, automotive Electric Water Pump. Suitable for all makes and models with an engine size up to 2 litres, and is a practical alternative to the mechanical belt-driven pump or fitted as an auxiliary pump.

Kit Contents

Description	Qty
EWP®80 Pump	1
Straight adaptor	1
Elbow adaptor	1
O ring	2
Wiring Harness	1
Rubber adaptor sleeve - 3mm (1/8")	2
Hose Clamps	2
Assorted hardware bag - includes relay #0533	1

Kit Options

Part #	Description	Qty
1025	Alloy adaptor - AN-16	1*
1026	Alloy adaptor - 1 1/4" NPT	1*
1027	Alloy adaptor straight - 25mm (1")	1*
1028	Alloy adaptor straight - 19mm (3/4")	1*
8301	Alloy elbow adaptor - 35mm (1 3/8")	1*
8302	Alloy straight adaptor - 35mm (1 3/8")	1*
8303	Alloy elbow adaptor - 38mm (1 1/2")	1*
8304	Alloy straight adaptor - 38mm (1 1/2")	1*
8511	Sleeve 6mm (1/4") rubber adaptor	1*

* 2 required if using at both ends

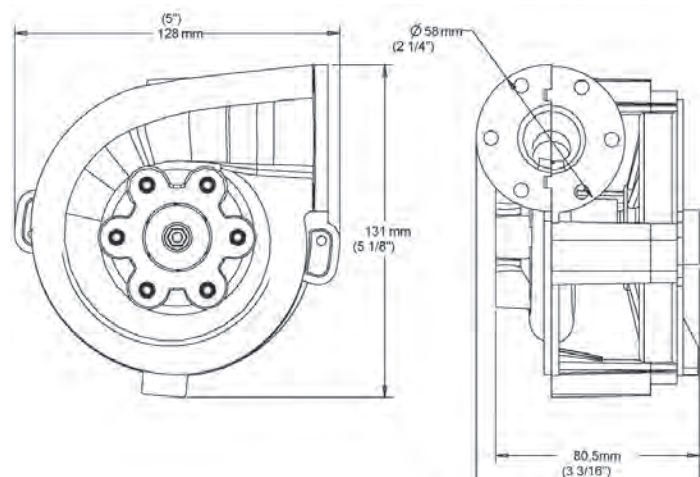

EBP[®] 40 Electric Booster Pump

12V - Part # 9040
24V - Part # 9041

EBP[®] 40 Electric Booster Pump

37 Litres per minute

12 & 24 Volt

A high-performance brushless motor, magnetic-drive pump. Compact and versatile pump for a range of applications.

This high-performance 37 litre per minute, brushless, magnetically-driven EBP[®] has drawn high acclaim globally for its diversity of applications. These include booster for car heater and LPG systems, solar and marine applications, water-cooled motorcycle, go-kart engines, turbo air/water intercoolers, caravans, motor homes and domestic irrigation.

The EBP[®]40 is offered in both 12 and 24 Volt.

Technical Specifications

	12 Volt Pump	24 Volt Pump
Motor	12 Volt Brushless	24 Volt Brushless
Operating voltage	9V DC to 15V DC	20V DC to 27V DC
Maximum current	4.6A @ 12V	2.5A @ 24V
Flow rate (max)	37 L/min (9.8 US gal/min)	37 L/min (9.8 US gal/min)
Maximum Pump Pressure	0.88 Bar (12.76 psi)	0.88 Bar (12.76 psi)
Operating temp.	-40° to 120°C (-40° to 248°F)	-40° to 120°C (-40° to 248°F)
Pump design	Recirculating centrifugal	Recirculating centrifugal
Pump weight	570 grams (1.26 lb)	570 grams (1.26 lb)
Pump material	PPS / PA66	PPS / PA66
Burst pressure	250 kPa (36 psi)	250 kPa (36 psi)
Fits hose sizes	19mm (¾")	19mm (¾")

The EBP[®] is a recirculating pump which is ideal for a 'closed system' similar to an automotive cooling system; it is not self priming'.

For optimum coolant flow control, use either of the Davies, Craig Thermatic Switches (#0400, #0444 or #0455). See pages 22-23.

Please see page 27 for pressure vs flow chart.



Kit Contents

Description	12V	24V	Qty
EBP [®] 40 24 Volt Electric Booster Pump		✓	1
EBP [®] 40 12 Volt Electric Booster Pump	✓		1
Mounting bracket	✓	✓	1

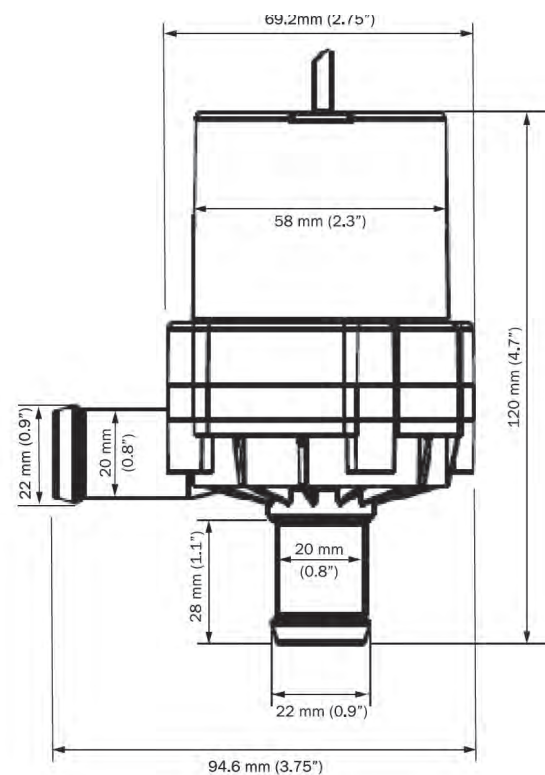

EBP® 25 Electric Booster Pump

Part # 9005
(12 Volt only)

EBP® 25 Electric Booster Pump

25 Litres per minute

12 Volt only

A high-performance brushless motor, magnetic-drive pump. Compact and versatile 12V pump for a range of applications.

This high-performance 25 litre per minute, 12 volt, brushless, magnetically-driven EBP has drawn high acclaim globally for its diversity of applications.

The many EBP® applications include use as a booster for car heater and LPG systems, solar and marine applications, water-cooled motorcycle, go-kart engines, turbo air/water intercoolers, caravans, motor homes and domestic irrigation.

Technical Specifications

	Description
Motor	12 Volt Brushless
Operating voltage	9V DC to 15V DC
Maximum current	3.5A
Flow rate (max)	25 L/min (6.6 US gal/min) @ 10 kPa
Maximum Pump Pressure	0.41 Bar (5.95 psi)
Operating temp.	-40° to 120° C (-40° to 248° F)
Pump design	Recirculating centrifugal
Pump weight	995 grams (2.19 lb)
Pump material	Nylon 66, 30% glass-filled
Burst pressure	250 kPa (36 psi) minimum
Fits hose sizes	19mm (3/4")



Kit Contents

Description	Qty
EBP®25 Electric Booster Pump	1
Wiring Harness	1

Optional

Part #	Description	Qty
9105	EBP®25 Electric Booster Pump only	1

The EBP® is a recirculating pump which is ideal for a 'closed system' similar to an automotive cooling system; it is not self priming'.

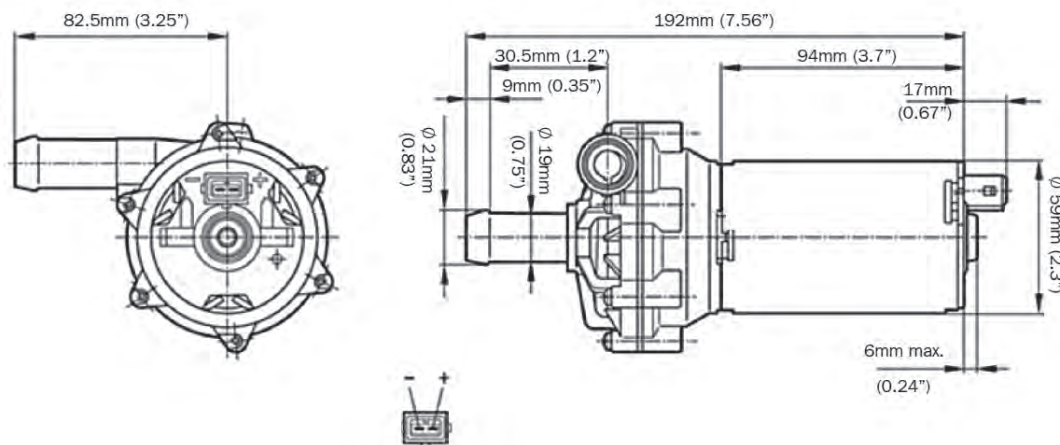

For optimum coolant flow control, use either of the Davies, Craig Thematic Switches (#0400, #0444 or #0455). See pages 22-23.

Please see page 27 for pressure vs flow chart.

EBP® 23 Electric Booster Pump

Part # 9050
(12 Volt only)

EBP® 23 Electric Booster Pump

23 Litres per minute

12 Volt only

A high-performance brushless motor, magnetic-drive pump. Compact and versatile 12V pump for a range of applications.

The EBP®23 is a 'brushless' 12 volt, high-flow (23 litres/6.08 US gallons per minute), magnetically-driven water pump.

The EBP® motor has no brushes to wear out. The pump is magnetically driven by the motor, which means that no shaft sealing is required.

The many EBP® applications include use as a booster for car heater and LPG systems, solar and marine applications, water-cooled motorcycle, go-kart engines, turbo air/water intercoolers, caravans, motor homes and domestic irrigation.



Technical Specifications

	Description
Motor	12 Volt Brushless
Operating voltage	9V DC to 15V DC
Maximum current	1.5A
Flow rate (max)	23 L/min (6 US gal/min) @ 20 kPa
Maximum Pump Pressure	0.25 Bar (3.63 psi)
Operating temp.	-40° to 120°C (-40° to 248°F)
Pump design	Recirculating centrifugal
Pump weight	364 grams (0.8 lb)
Pump material	Nylon 66, 30% glass-filled
Burst pressure	250 kPa (36 psi) minimum
Fits hose sizes	12.5mm to 19mm (½" to ¾") using stepped adaptors

Kit Contents

Description	Qty
EBP®23 Electric Booster Pump	1
Adaptor - stepped: 19mm (¾"), 15mm, 12.5mm (½")	2
Hose Clamps	4
Hose	2
Mounting bracket	1
Fitting instructions	1

Optional

Part #	Description	Qty
9051	EBP®23 Electric Booster Pump with mounting Bracket	1

For optimum coolant flow control, use either of the Davies, Craig Thematic Switches (#0400, #0444 or #0455). See pages 22-23.

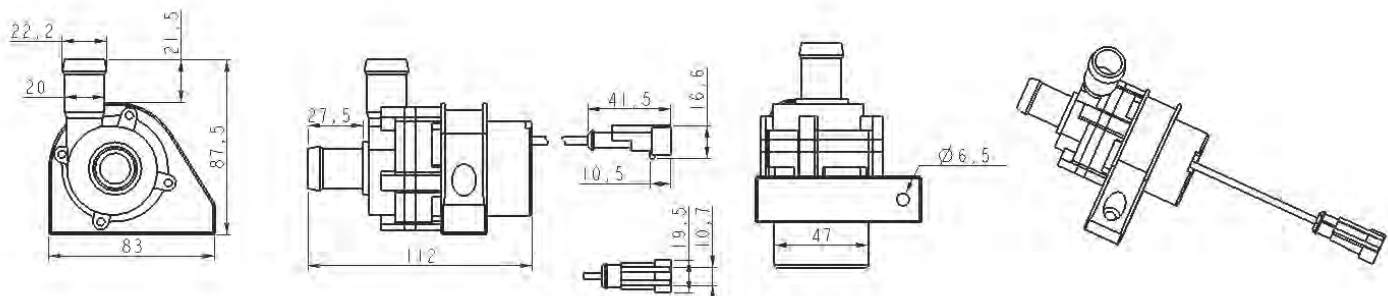

Please see page 27 for pressure vs flow chart.

EBP® 15 Electric Booster Pump

Part # 9001
(12 Volt only)

EBP®15 Electric Booster Pump

15 Litres per minute

12 Volt only

A high-performance brushless motor, magnetic-drive pump. Compact and versatile 12V pump for a range of applications.

Davies, Craig developed the Electric Booster Pump (EBP®15), designed for use with either an EWP® or a conventional mechanical water pump to enhance the heater and LPG systems.

This high-performance 15 litre per minute, 12 volt, brushless, magnetically-driven EBP® has drawn high acclaim globally for its diversity of applications. These include booster for car heater and LPG systems, solar and marine applications, water-cooled motorcycle, go-kart engines, turbo air/water intercoolers, caravans, motor homes and domestic irrigation.



Technical Specifications

	Description
Motor	12 Volt Brushless
Operating voltage	9V DC to 15V DC
Maximum current	1.3A
Flow rate (max)	15 L/min (4 US gal/min) @ 10 kPa
Maximum Pump Pressure	0.2 Bar (2.9 psi)
Operating temp.	-40° to 120°C (-40° to 248°F)
Pump design	Recirculating centrifugal
Pump weight	245 grams (0.54 lb)
Pump material	Nylon 66, 30% glass-filled
Burst pressure	250 kPa (36 psi) minimum
Fits hose sizes	12.5mm to 19mm (½" to ¾") using stepped adaptors

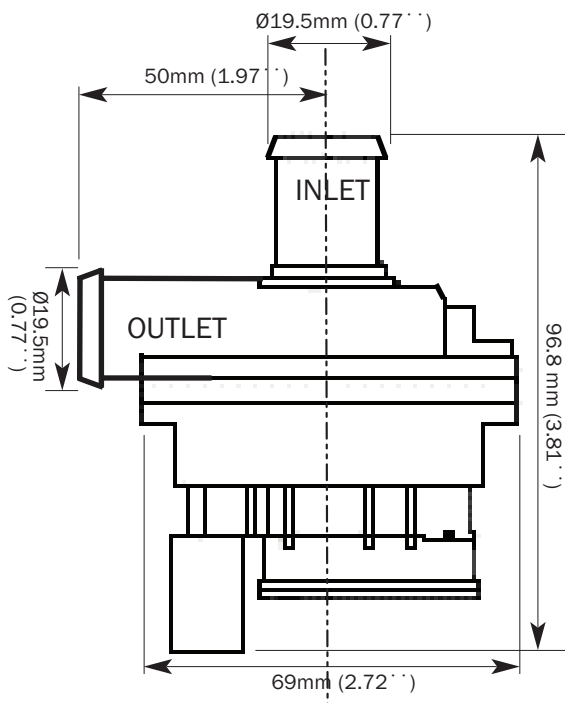

The EBP® is a recirculating pump which is ideal for a 'closed system' similar to an automotive cooling system; it is not self priming'.

For optimum coolant flow control, use either of the Davies, Craig Thematic Switches (#0400, #0444 or #0455). See pages 22-23.

Please see page 27 for pressure vs flow chart.

Kit Contents

Description	Qty
EBP®15 Electric Booster Pump	1
Adaptor - stepped: 19mm (¾"), 15mm (9/16"), 12.5mm (½")	2
Hose clamps	4
Hose	2
Wiring harness	1
Fitting instructions	1

Optional

Part #	Description	Qty
9002	EBP®15 Electric Booster Pump with wiring harness	1

Thermatic® Switches

Davies, Craig offers three types of Thermatic® Switches:

- Part #0444 senses air temperature near the top radiator hose as it passes through the radiator or senses coolant temperature (with #0409) for EWP® single or twin fan operation.
- Part #0455 Premium Thermatic Switch senses both air or coolant temperatures (with #0409), EWP® single or twin fan operation, attractive dashboard mounted monitor.
- Part #0401 senses the coolant temperature after it passes through the engine block prior to entering the radiator.

Part #0400 is a combination of the unit #0401 (opposite) and the #0409 Hose Adaptor (opposite), offering probe placement in the top radiator hose.

Part #0444

Digital Thermatic® Switch

12 & 24 Volt

The Digital Thermatic® Switch can sense air or coolant temperature to automatically activate single or twin fans or a fan and/or EWP® at your set/targeted temperature when extra cooling is required.

With dual relays, the switch provides dual fan activation up to 50 Amps at an engine temperature range of 40 °C to 110 °C (104 ° to 230 °F). Equipped with a proven sensor positioned for accurate temperature readings.

Simple, convenient DIY fitting.

Note: #0409 must be used for top radiator hose fitment.



All Thermatic® Switches feature:

- automatically activate the EWP® at the set/targeted temperature when cooling is required;
- can be adjusted over a wide temperature range by simply turning a knob located on the control switch (#0401).
Push-button scrolling through the 40 °C to 110 °C temperature range (#0444 & #0455);
- can be employed to operate the Electric Water Pump when operated as an auxiliary pump to the mechanical water pump;
- are ideal for dual-fan operation (#0444 & #0455).

Part #0455

Premium Digital Thermatic® Switch

12 & 24 Volt

The Premium Digital Thermatic® Switch automatically activates single or twin fans or a fan and/or EWP® at your set/targeted temperature when extra cooling is required.

Attractive compact dashboard, driving compartment mounting LED display module, this state-of-the-art switch can also operate your air conditioning fan.

- **Temperature Set LED**
- **Seperate LED indicators for each fan**
- **Air Conditioning override LED**
- **Temperature Sensor short circuit display**

The 5mm probe can be placed in the fins at the top of the radiator sensing air or in the top radiator hose (with #0409) to sense the engine coolant temperature.



Questions? Please see "frequently-asked questions" on our website: www.daviescraig.com.au

Thermatic® Switches

Part #0401

Mechanical Thermatic® Switch 12V & 24V

The Mechanical Thermatic® Switch is adjustable from 40° to 100°C (104° to 212°F).

The Thermatic® Switch is mounted near the radiator and the stainless steel probe fitted inside the radiator hose.

The Thermatic® Switch is then connected to the ignition circuit for operation.



Part #0400

Thermatic® Switch Combo 12 & 24 Volt

The thermal switch is adjustable from 40° to 100°C (104° to 212°F). No need to squeeze the probe of the Mechanical Thermal Switch between the radiator inlet and radiator hose. This simple kit allows easy fitting directly into the radiator hose.



Part #0404

Mechanical Thermatic® Switch (12V & 24V) plus Relay for Air Conditioning

The Mechanical Thermatic® Switch is adjustable from 40° to 100°C (104° to 212°F).

The Thermatic® Switch is mounted near the radiator and the stainless steel probe fitted inside the radiator hose. The Thermatic® Switch is then connected to the ignition circuit for operation.

The Thermatic® Switch and relay kit enables a fan to operate both thermally and also when the air conditioning is running.



Part #0409

Temperature Sensor Adaptor Kit

No need to squeeze the probe of the Mechanical Thermatic® Switch between the radiator inlet and radiator hose, or the radiator fins.

This simple, economical Adaptor Kit allows easy fitting directly into the top radiator hose. Just fit the probe into the compression fitting, remove about 17mm (2/3") of radiator hose, fit the adaptor between each hose and secure the hose clamps. The kit comes complete, as shown, for a watertight and effective probe installation. Extra rubber sleeves are supplied to enable fitment to radiator hose sizes from 32mm to 40mm (1¼" to 1½") diameter.

Suits all temperature sensors with either a 5mm (3/16") or a 6mm (1/4") outside diameter and temperature gauge senders with 6mm (1/4") NPT thread.

Note: This is an accessory for use with #0401, #0404, #0444 and #0455 Thermatic® Switches.



EWP[®] Header Adaptors Kits

Davies, Craig's EWP[®] Header Adaptor Kits are designed for use with an EWP[®] Electric Water Pump Combo Kits to replace your existing belt-driven mechanical water pump. Choose the Header Adaptor Kit that suits your engine:

Chevrolet BB/SB engines

Part #	Contents
8610	EWP [®] Header Adaptor Kit - BLUE colour Suits small block Chev.
8611	EWP [®] Header Adaptor Kit - BLACK colour Suits small block Chev.
8620	EWP [®] Header Adaptor Kit - BLUE colour Suits big block Chev.
8621	EWP [®] Header Adaptor Kit - BLACK colour Suits big block Chev.



Ford BB engines

Part #	Contents
8630	EWP [®] Header Adaptor Kit (blue hose)
8631	EWP [®] Header Adaptor Kit (black hose)



Ford Coyote 5.0 Litre Engines

Part #	Contents
8660	EWP [®] Header Adaptor Kit



Holden V8 Engines

Part #	Contents
8600	EWP [®] Header adaptor kit - suits Holden 253 / 308



LS Series Engines

Part #	Contents
8650	EWP [®] Header Adaptor Kit - black hose



Ford Windsor V8 Engines

Part #	Contents
8640	EWP [®] Header Adaptor Kit



EWP[®] Accessories

EWP[®] Nylon Adaptors

Part #	Contents
8307	Straight adaptor 35mm (1 $\frac{3}{8}$ ")
8309	Elbow adaptor 35mm (1 $\frac{3}{8}$ ")
8510	3mm ($\frac{1}{8}$ ") sleeves rubber adaptor
8511	6mm ($\frac{1}{4}$ ") sleeves rubber adaptor
8509	O ring



#8380

EWP[®] Alloy Heater Return Kit

Part #	Contents
8380	EWP [®] Heater Return Kit Components: #8318 and #8532.



Part #8700

EWP[®] Mounting Bracket

The Davies Craig EWP[®] Mounting Bracket can be used with the EWP[®]15(EWP[®]130 and EWP[®]115 (both nylon and alloy versions). The mounting bracket offers greater flexibility and assists with the hard mounting of the EWP[®] to the engine bay by providing a rubber dampener to minimise vibrator



Part #8505

90° Hose adaptor

Fits all EWP[®] Water Pumps

Part #	Contents
8505	90 Hose adaptor 38mm (1 $\frac{1}{2}$ ")



EWP[®] Alloy Adaptors

Part #	Contents
1024	EWP [®] 90° Alloy Swivel Elbow adaptor
1025	Alloy adaptor - AN-16
1026	Alloy adaptor - 1 $\frac{3}{4}$ NPT
1027	Alloy straight adaptor - 25mm (1")
1028	Alloy straight adaptor - 19mm ($\frac{3}{4}$ ")
8301	Alloy adaptor elbow - 35mm (1 $\frac{3}{8}$ ")
8302	Alloy adaptor straight - 35mm (1 $\frac{3}{8}$ ")
8303	Alloy adaptor elbow - 38mm (1 $\frac{1}{2}$ ")
8304	Alloy adaptor straight - 38mm (1 $\frac{1}{2}$ ")



Part #1035

Low Coolant Level Alarm - 12 & 24 Volt

The Davies, Craig Low Coolant Level Alarm monitors coolant levels in engines to help prevent overheating and consequential failure.

It simply fits to your engine's top radiator hose and alerts you to the loss of engine coolant.

This kit's module, mounted in the driving compartment, will sound an audible alarm and flash a bright red LED when the engine coolant level drops.

This situation can occur when a radiator hose splits or frays and starts to lose the engine's coolant, or if the vehicle's radiator were to spring a leak in the core.



EWP[®] - Pressure Vs Flow



EWP[®] Pressure Vs Flow

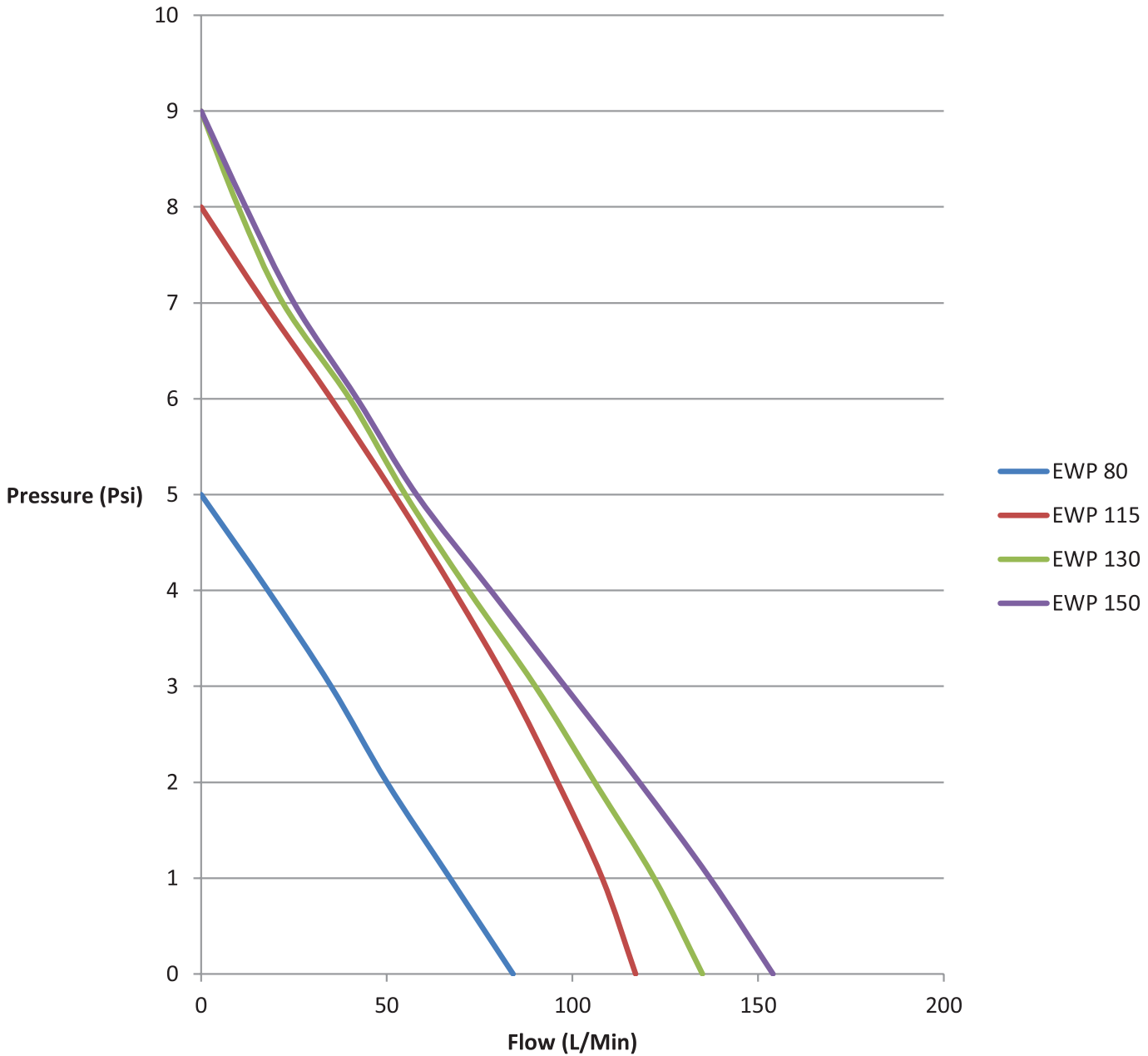

EBP[®] - Pressure Vs Flow



EBP[®] Pressure Vs Flow

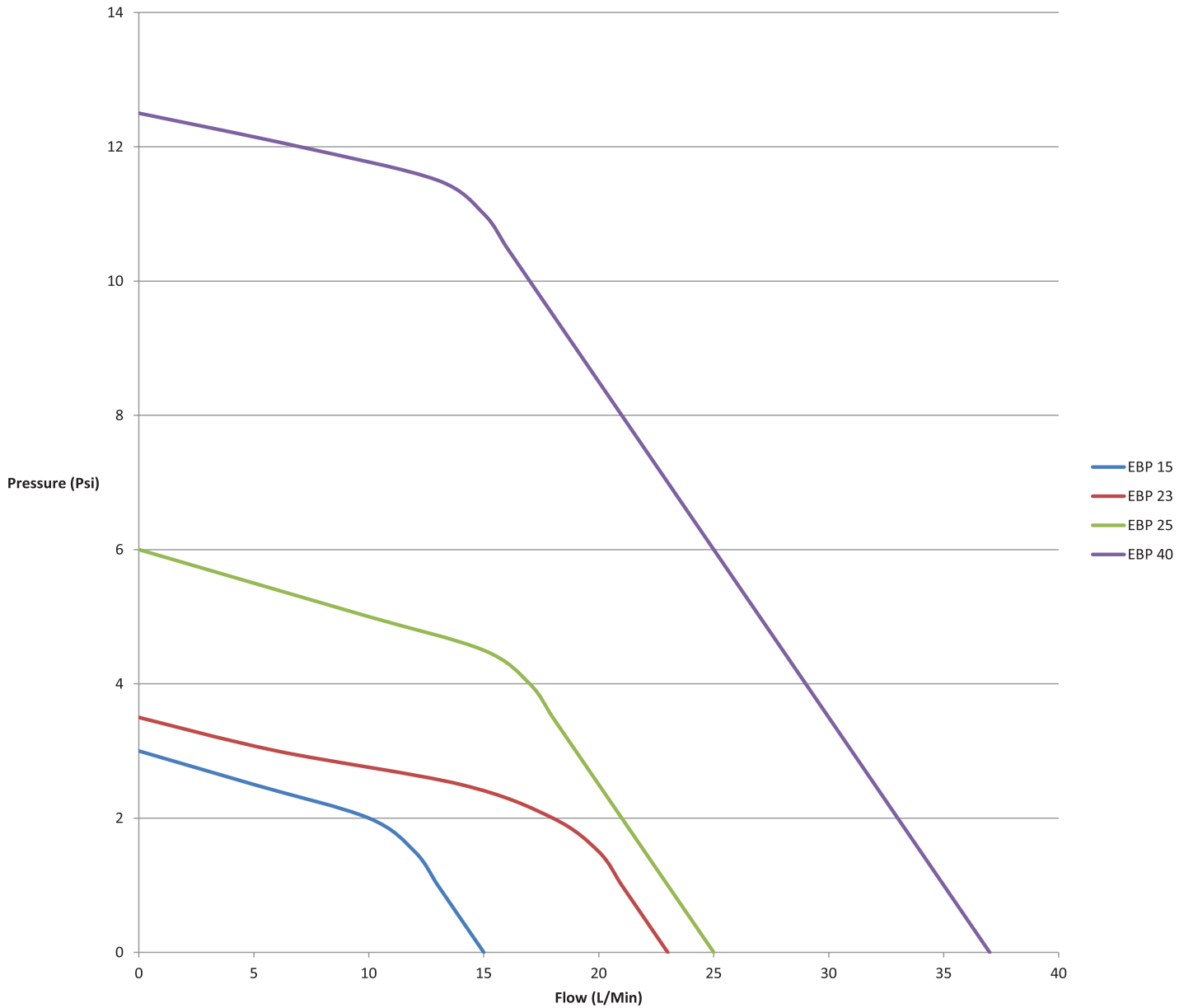

WARRANTY



Davies, Craig Pty Ltd hereby warrants these products for a period of two (2) years, 40,000km or 2000 hours continuous running (whichever is the lesser) from the date of purchase. Davies, Craig Pty Ltd shall carry out any repairs/replacement to the Electric Water Pump, EWP[®]/Fan Digital Controller and/or EWP[®] Header-Adaptor Kit free of cost provided that such fault is directly attributable to a defect in the workmanship or materials used in the manufacture of the Davies, Craig products supplied. Labour and consequential costs excluded.



REPLACES BELT-DRIVEN WATER PUMPS

Electric Water Pumps
Thermatic® Fans
Digital Controller

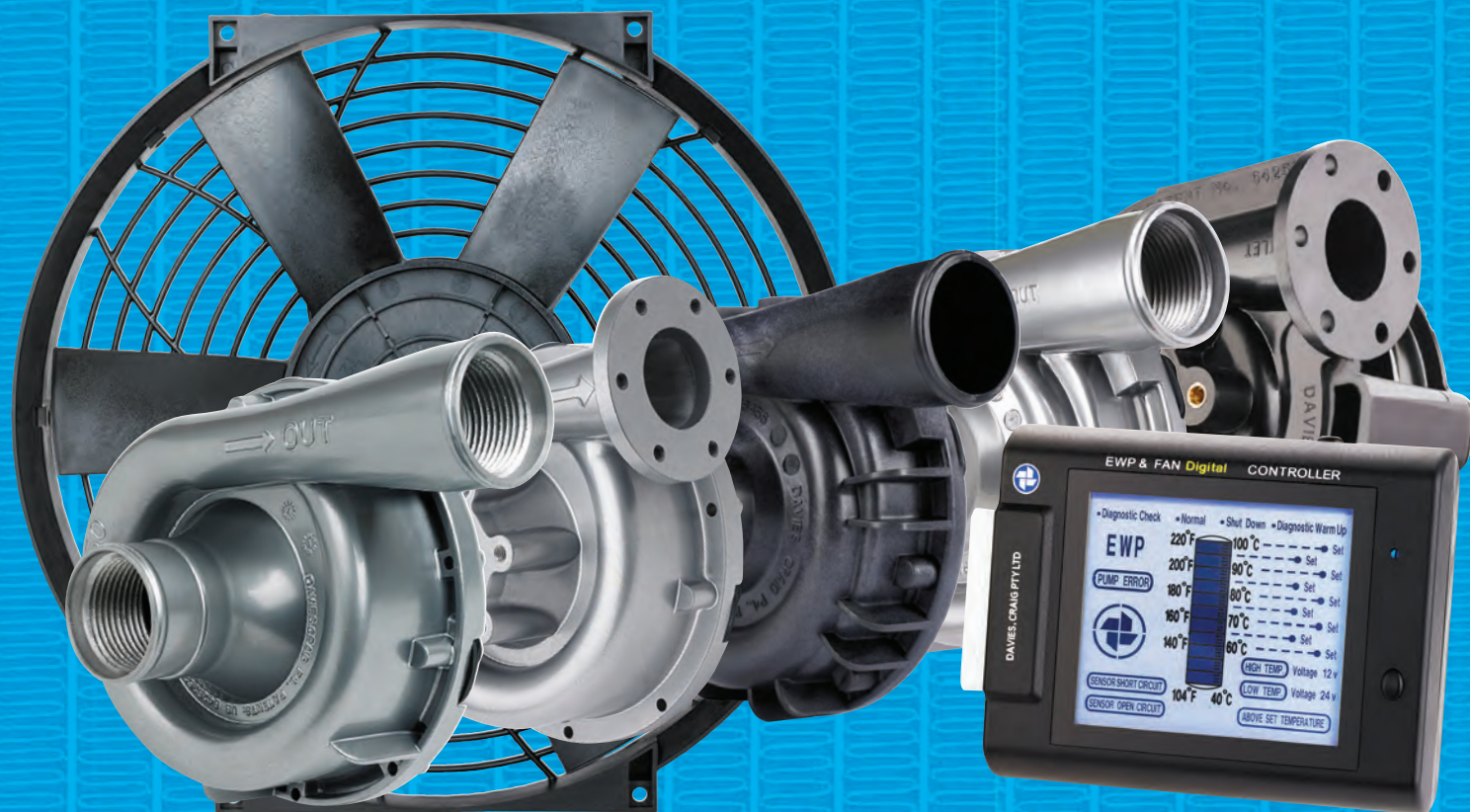

Shop online for all your automotive cooling needs: www.daviescraig.com.au

or call +61 3 9369 1234 for your nearest outlet

- **Electric Water Pumps** ● **Digital Controller** ● **Thermatic® Fans** ● **Transmission & Power Steering Oil Coolers**

DISTRIBUTORS – see www.daviescraig.com.au for distributors' details



**DAVIES,
CRAIG** PTY. LTD.

INNOVATION - QUALITY - RANGE

Davies, Craig Pty Ltd ABN 71 004 918 825

Registered Office:

77 Taras Ave, Altona North VIC 3025 Australia

PO Box 363, Altona North VIC 3025 Australia

Ph: +61 3 9369 1234 Fax: + 61 3 9369 3456

Email: info@daviescraig.com.au

www.daviescraig.com.au

2
YEAR
WARRANTY



Australian Made

Your local stockist is:

