



*QUALITY... PLAIN & SIMPLE®*

---

CATALOG 27

---



# Contents

## Automatic Transmission Shifters

TRANSMOUNT AUTOMATIC TRANSMISSION SHIFTER	2
TAIL MOUNT AUTOMATIC TRANSMISSION SHIFTERS	2
BELL CRANK KITS	2
FLOOR MOUNT AUTOMATIC TRANSMISSION SHIFTERS	3
CABLE OPERATED AUTOMATIC TRANSMISSION SHIFTERS	4
MUSCLE CAR AUTOMATIC TRANSMISSION SHIFTERS	5
SHIFTER LEVER STYLE & LENGTH OPTIONS	6
IDENTIFYING THE LOKAR SHIFTER (PART NUMBER DESIGNATIONS)	7
TRANSMISSION PAN IDENTIFICATION CHART	7

## Shifter Knobs & Adapters

ALUMINUM SHIFTER KNOBS	8
LOKAR SHIFTER KNOB ADAPTER	9
MUSCLE CAR SHIFTER KNOB ADAPTER	9
KNOBS FOR LOKAR SHIFTER KNOB ADAPTER	9

## Automatic Transmission Accessory Parts

COLUMN CABLE SHIFT LINKAGE	10
BACK-UP LIGHT OR NEUTRAL SAFETY SWITCH KIT	10
GM & FORD ADJUSTABLE COLUMN SHIFT LINKAGE	11
FORD AOD SELECTOR SHAFT & ARM	12
BILLET ALUMINUM ADJUSTABLE TRANS SHIFT ARM	12
LEVER CONVERSION KITS	12
SPARE SHIFTER COMPONENT PARTS	12

## Electronic Shifters

AUTOMATIC ELECTRONIC SPORT MODE SHIFTER	13
---	----

## Manual Transmission Accessories

MANUAL TRANSMISSION SHIFTER KNOBS	14
MANUAL SHIFT LEVER ADAPTER	14
MANUAL TRANSMISSION SHIFT LEVERS	15

## Shifter Boots, Bezels, & Ring Sets

SHIFTER BOOT & RING SETS	16
HI-TOP & DELUXE TOP SHIFTER BOOTS & BEZELS	17

## Shift Indicators & Speedometer Cables

BILLET ALUMINUM LED DASH INDICATORS	18
BILLET ALUMINUM LED BOOT INDICATORS	19
CABLE OPERATED LED SHIFT INDICATOR SENSOR KITS	20
"U-CUT-TO-FIT" SPEEDOMETER CABLE KITS	21

## Interior Products

OVAL BILLET ALUMINUM DASH INSERTS	22
GOOLSBY EDITION BILLET ALUMINUM DASH INSERTS	23
GOOLSBY EDITION 1932 FORD DOOR SILLS	23
BILLET ALUMINUM COLUMN WARE™	24
BILLET ALUMINUM DOOR PULLS	24
GOOLSBY EDGE EDITION DOOR PULLS	24
OVAL BILLET ALUMINUM INTERIOR DOOR HANDLES	25
UNIVERSAL DOOR LATCH CABLE RELEASE KIT	25
BILLET ALUMINUM DOOR HANDLES, WINDOW CRANKS, & VENT WINDOW CRANKS	26
LAKESTER™ DOOR HANDLES, WINDOW CRANKS, & VENT WINDOW CRANKS	27
HOOD & TRUNK RELEASE CABLE KITS	28
ADJUSTABLE-LEVEL SELF-LOCKING HOOD & TRUNK PROP	28

## Emergency Brakes & Cables

FLOOR MOUNT EMERGENCY HAND BRAKE	29
EMERGENCY BRAKE WARNING INDICATOR SWITCH KIT	29
HAND BRAKE BOOT SETS	29
UNDER-THE-DASH HAND OPERATED EMERGENCY BRAKE	30
TRANSMOUNT EMERGENCY HAND BRAKE	30
UNDER-THE-DASH FOOT OPERATED EMERGENCY BRAKE	31

## Emergency Brake Cables & Connector Cables

UNIVERSAL EMERGENCY BRAKE CABLES	32
TRANSMOUNT EMERGENCY BRAKE CABLES	33
U-CUT-TO-FIT REAR BRAKE CABLE KIT FOR 42 TO 54 CHEVY TRUCKS	33
CONNECTOR CABLES FOR ORIGINAL FACTORY UNDER-THE-DASH HAND BRAKES	34
CONNECTOR CABLES FOR UNDER-THE-DASH EMERGENCY BRAKES	34
REAR BRAKE CLEVIS KITS	34

## Exterior Products

BILLET ALUMINUM OVAL LED TAILLIGHTS	35
ANCHOR-TIGHT® HEADLIGHT BRAIDS	35
GOOLSBY EDITION BILLET 12V EXTERIOR DOOR HANDLES	36
EARLY FORD RADIATOR CAP	36
GOOLSBY EDITION BILLET ALUMINUM HOOD VENTS	37
GOOLSBY EDITION BILLET ALUMINUM EXHAUST TIPS	37

## Throttle Cables & Kickdowns

HI-TECH THROTTLE CABLES	38
POLISHED HI-TECH THROTTLE CABLES	39
DUO-PAK KITS	39
HI-TECH BLOWER DRIVE THROTTLE CABLES & KICKDOWNS	40
HI-TECH KICKDOWNS	41
THROTTLE BODY & CARB END FITTINGS	42
KICKDOWN END FITTINGS	42
SPARE THROTTLE CABLE COMPONENT PARTS	42
HI-TECH TH400 ELECTRIC KICKDOWN KIT	43
TH350 STAINLESS KICKDOWN BRACKET & CABLE	43
"U-CUT-TO-FIT" CRUISE CONTROL CABLES	44

## Throttle Cable Bracket & Spring Kits

STAINLESS STEEL CARBURETOR BRACKET & RETURN SPRINGS	45
TUNED-PORT BRACKETS	45
LT1 & LT4 BRACKETS	45
LSI BRACKETS	46
RAM JET BRACKETS	46
THROTTLE/KICKDOWN CABLE BRACKET FOR EDELBROCK PRO-FLO® XT	46
EFI BRACKET	47
TRI-POWER BRACKET & SPRING KIT	47
THROTTLE/KICKDOWN CABLE MOUNTING BRACKET FOR STROMBERG® STYLE CARBURETORS	47
THROTTLE CABLE MOUNTING BRACKET & SPRING RETURN KIT FOR 4150 SERIES CARBURETORS	48
THROTTLE/KICKDOWN CABLE MOUNTING BRACKET FOR STREET DEMON™ CARBURETORS	48
BILLET THROTTLE/KICKDOWN BRACKET FOR BARRY GRANT SIX SHOOTER	48
BILLET ALUMINUM THROTTLE/KICKDOWN BRACKET & SPACER KIT FOR EDELBROCK PRO-FLO® FUEL INJECTION	49
BILLET THROTTLE/KICKDOWN CABLE MOUNTING BRACKET FOR EDELBROCK 4-BARREL	49
BILLET PROGRESSIVE LINKAGE SYSTEM	49

## Drive-By-Wire Throttle Assemblies

BILLET DRIVE-BY-WIRE ELECTRONIC THROTTLE CONTROL PEDAL ASSEMBLIES	50
DRIVE-BY-WIRE PEDAL OPTIONS	51
DIRECT FIT DRIVE-BY-WIRE THROTTLE PEDAL PADS	51

## Throttle Assemblies & Pedal Pads

STANDARD BILLET THROTTLE ASSEMBLIES & PEDAL PADS	52
XL SERIES BILLET THROTTLE ASSEMBLIES & PEDAL PADS	53
ELIMINATOR FLOOR MOUNT THROTTLE PEDALS	54
BILLET ALUMINUM ADJUSTABLE FOOT RESTS	54
OVAL BILLET THROTTLE ASSEMBLIES & PEDAL PADS	55
COMPETITOR™ SERIES THROTTLE ASSEMBLIES	56
LAKESTER™ SERIES THROTTLE ASSEMBLIES	56
STEEL THROTTLE ASSEMBLIES & PEDAL PADS	57
STEEL SPOON THROTTLE ASSEMBLIES & PEDAL PADS	57
GOOLSBY EDGE EDITION THROTTLE ASSEMBLY & PEDAL PADS	58
GOOLSBY EDITION THROTTLE PEDAL ASSEMBLY & PEDAL PADS	58

## Direct Fit Pedals & Pads

GOOLSBY EDITION BRAKE & CLUTCH ARMS	59
BILLET DIRECT FIT BRAKE & CLUTCH PEDAL ARMS	59
55-57 CHEVY PEDALS & PADS	60
67-69 CAMARO/FIREBIRD PEDALS & PADS	62
64-67 CHEVELLE THROTTLE PEDAL ASSEMBLIES & PADS	63
CHEVY/GMC C-10 PEDALS & PADS	64
LATE CHEVY TRUCK THROTTLE, BRAKE, & E-BRAKE PADS	65
62-72 CHEVY II/NOVA THROTTLE PEDAL ASSEMBLIES & PADS	66
58-62 CORVETTE BRAKE/CLUTCH PADS	66
58-65 FULL SIZE CHEVY CURVED BRAKE & CLUTCH PADS	66
67-69 DART/CUDA COMPETITOR™ SERIES THROTTLE ASSEMBLIES & PEDAL PADS	67
64-70 MUSTANG THROTTLE PEDAL ASSEMBLIES & PEDAL PADS	68
EARLY FORD BRONCO THROTTLE, BRAKE, & CLUTCH PADS	69
BILLET DIRECT FIT JEEP THROTTLE, BRAKE, & CLUTCH PADS	69

## Transmission & Engine Dipsticks

HI-TECH FLEXIBLE BRAIDED TRANSMISSION DIPSTICKS	70
ANCHOR-TIGHT® LOCKING FLEXIBLE TRANSMISSION DIPSTICKS	71
FLEXIBLE ENGINE DIPSTICKS	73
BIG BLOCK FLEXIBLE ENGINE DIPSTICKS	74
LS/COYOTE GAUGE TO FIT ENGINE DIPSTICKS	74
ANCHOR-TIGHT® LOCKING FLEXIBLE ENGINE DIPSTICKS	75
PREMIUM BILLET ALUMINUM DIPSTICK HANDLES	76

## Lokar Motorsports - Drag Racing Products

INTERIOR BATTERY DISCONNECT LEVER KIT	77
DIAL-IN BOARD MOUNTING BRACKETS	78
BILLET ALUMINUM SAFETY LED TAILLIGHT	78
4500/4150 SERIES CARBURETOR BRACKETS & SPRING RETURN KITS	79

## Lokar Wear

T-SHIRTS & HOODIE SWEATSHIRTS	80
-------------------------------	----





# Automatic Transmission Shifters

For nearly three decades, automotive enthusiasts have experienced and enjoyed the superior craftsmanship, design and safety features of Lokar Automatic Transmission Shifters. When Lokar builds a shifter, whether it's for a hot rod, street rod, truck, muscle car or off-road vehicle, safety is the first and foremost consideration.

The Lokar Collection of Shifters is designed to prevent accidental shifting from the Park position into Reverse, Drive, and Low gears with our Exclusive Safety Lock-Out Button. When adjusted properly, the Safety Lock-Out Button is flush with the knob and is virtually undetectable. Lokar also offers Shifter Knob Adapters for individuals who wish to personalize their shifter with a custom knob (See Page 9).

Lokar prides itself in the design and versatile mounting capabilities of their shifters. With Lokar's exclusive and innovative main plate and side brackets the shifters can be mounted in a number of positions front to rear, allowing the use of an existing floor opening or to create a unique location.

## FEATURES

- Positive Lock-Out in Park and Neutral
- Neutral Safety Switch
- Operates with solid adjustable linkage
- Utilizes high quality rod ends
- Gold iridited main plate and brackets
- All hardware included
- Lever adjustments for dash and seat clearance
- 360 degree lever rotation for extra leg space
- Teflon®-lined shifter knob buttons for smooth operation
- Easy to remove shifter knobs for simple boot installation
- Available for GM, Ford and Chrysler Automatic Transmissions\*
- Levers available in chrome-plated or black powder coat finish
- Levers available in 23", 16", 12", 10", 8" and 6" lengths\*
- Choice of Original Mushroom, Black Anodized Mushroom, Hi-Tech, Lokar or Black Anodized Lokar Knob factory installed with shifters\*
- Accessory knobs available separately
- Shifter Boots sold separately

**\*Please specify transmission type, lever length and knob style when ordering**

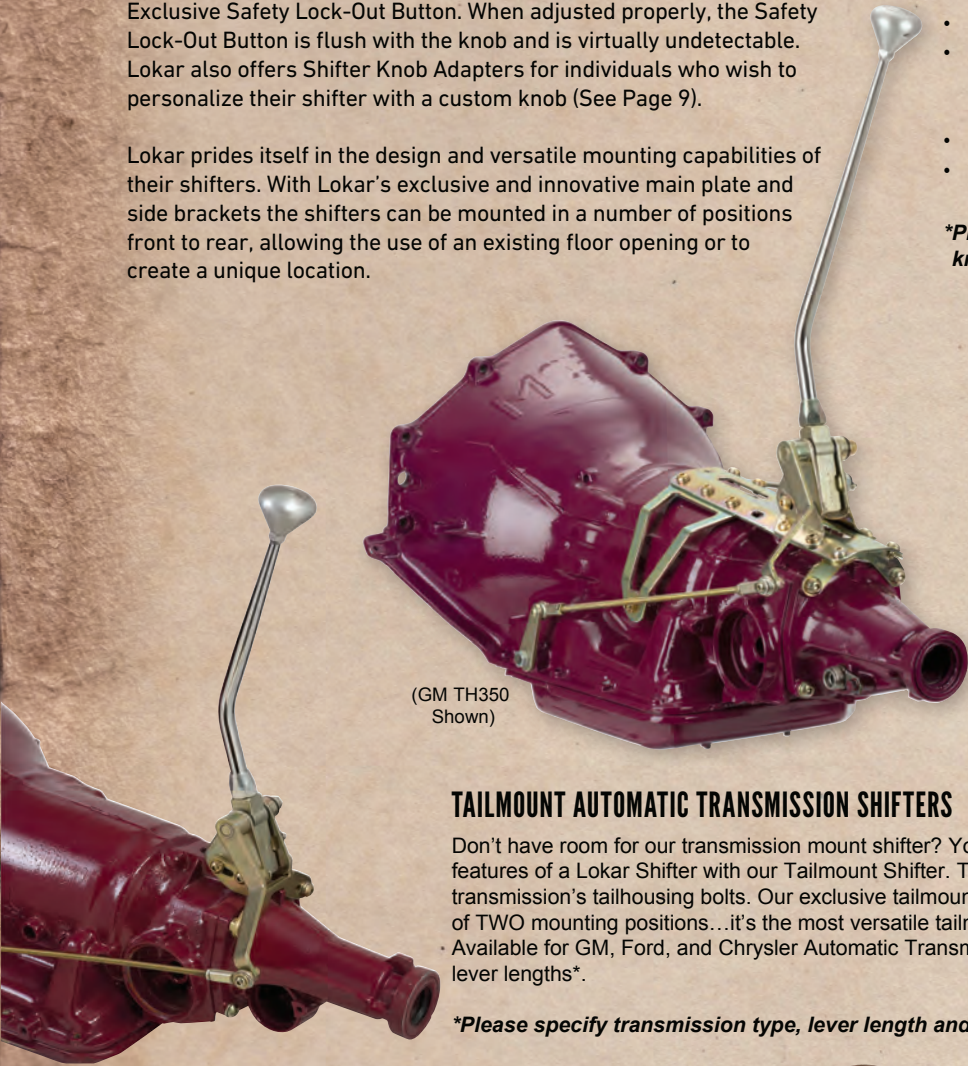

(GM TH350 Shown)



Black Powder Coated



Neutral Safety Switch

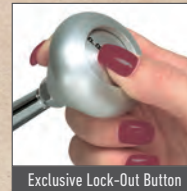

Exclusive Lock-Out Button



Can be mounted facing either forward or rear.

## TAILMOUNT AUTOMATIC TRANSMISSION SHIFTERS

Don't have room for our transmission mount shifter? You can have the safety and features of a Lokar Shifter with our Tailmount Shifter. This design mounts to the transmission's tailhousing bolts. Our exclusive tailmount bracket gives you a choice of TWO mounting positions...it's the most versatile tailmount shifter available.

Available for GM, Ford, and Chrysler Automatic Transmissions in 12", 10", 8" and 6" lever lengths\*.

**\*Please specify transmission type, lever length and knob style when ordering**

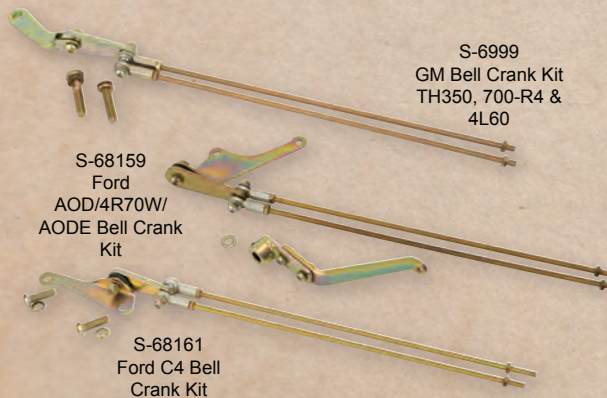

S-6999  
GM Bell Crank Kit  
TH350, 700-R4 &  
4L60

S-68159  
Ford  
AOD/4R70W/  
AODE Bell Crank  
Kit

S-68161  
Ford C4 Bell  
Crank Kit



Identifying the Lokar Shifter Part # (See Page 7)

## LOKAR BELL CRANK KITS

Lokar Bell Crank Kits are designed for use with Lokar Automatic Transmission Shifters when mounting the shifter all the way forward on the main plate. These kits come complete with all the necessary installation hardware.

PART NO.	DESCRIPTION
S-6999	GM TH350, 700-R4 and 4L60 Bell Crank Kit
S-68159	Ford AOD, 4R70W, AODE Bell Crank Kit
S-68161	Ford C4 Bell Crank Kit
S-7162	Bell Crank Arm Kit



# Floor Mount Automatic Transmission Shifters

Is your tunnel space too limited to use Lokar's transmission mounted shifter? Consider our Floor Mount Automatic Transmission Shifter. As its name implies, the shifter mounts to the floor on the transmission tunnel using our exclusive mounting brackets. But that's not all, in the name of versatility, Lokar includes three arms for offset mounting (especially helpful when mounting through existing consoles). Better yet, it retains all the same outstanding features of our transmission mounted shifter. When selecting a shifter boot, Lokar recommends one of our rectangular style Shifter Boots with a floor mount shifter.



## FEATURES

- Positive Lock-Out in Park and Neutral
- Neutral Safety Switch
- Operates with solid adjustable linkage
- Utilizes high quality rod ends
- Gold iridited main plate and brackets
- All hardware included
- Lever adjustments for dash and seat clearance
- 360 degree lever rotation for extra leg space
- Teflon®-lined shifter knob buttons for smooth operation
- Easy to remove shifter knobs for simple boot installation
- Available for GM, Ford and Chrysler Automatic Transmissions\*
- Levers available in chrome-plated or black powder coat finish
- Levers available in 32", 23", 16", 12", 10", 8" and 6" lengths\*
- Choice of Original Mushroom, Black Anodized Mushroom, Hi-Tech, Lokar, or Black Anodized Lokar Knob factory installed with shifters\*
- Accessory knobs available separately
- Shifter Boots sold separately
- Floor Mount Shifters available in Nostalgia style.

**\*Please specify transmission type, lever length and knob style when ordering**

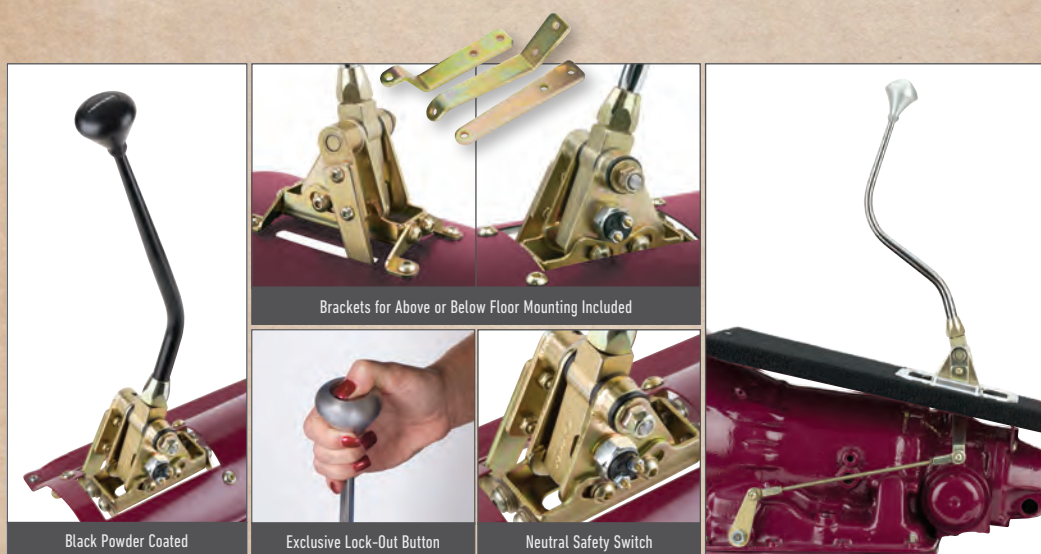

Black Powder Coated

Brackets for Above or Below Floor Mounting Included

Exclusive Lock-Out Button

Neutral Safety Switch



Tailmount, Floor Mount, and Cable Operated Shifters DO NOT offer the capability of mounting our Transmount Hand Brake.





# Cable Operated Automatic Transmission Shifters

Astounding versatility best describes this style of the Lokar Collection of Shifters. Lokar's versatile Floor Mount Shifter is paired with our high quality push/pull cable, offering mounting in virtually any location. This is especially useful when obstructions or personal preference for location are the driving factors upon installation. The use of a durable 1/4" inner cable and spherical rod ends bring this shifter to the next level of quality. User friendly mounting brackets and hardware yields a truly universal product.



Black Powder Coated

## Features

- All the same features of our versatile Floor Mount Design\*
- Operates with high quality 4' push/pull cable with durable 1/4" inner cable
- Spherical rod ends
- Many mounting options
- Cable Operated Shifters available in Nostalgia style

**\*Please specify transmission type, lever length and knob style when ordering.**



**ORDERING TIP**

Use Lokar's Floor Mount Hand Brake or Under-the-Dash Hand / Foot Brake with the Tailmount, Floor Mount, and Cable Operated Shifters. (See Pages 29-31)

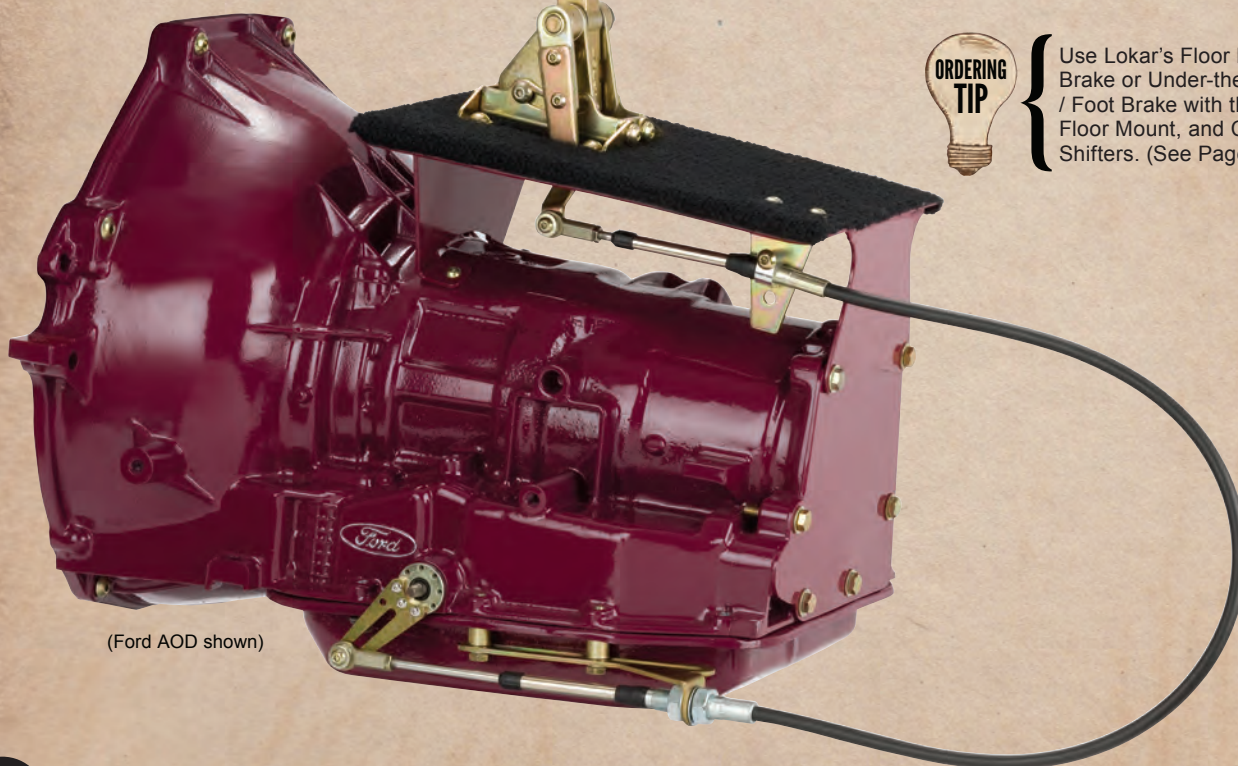

(Ford AOD shown)



# Muscle Car Automatic Transmission Shifters

Enjoy the look and feel of a classic 4-Speed Muscle Car Shifter by ordering one of our shifters with a pre-installed muscle car shift knob adapter. This shifter will give you the same "pull up to shift" tactile feel as the early Corvette shifter.

## FEATURES

- Positive Lock-Out in Park and Neutral
- Neutral Safety Switch
- Operates with solid adjustable linkage
- Utilizes high quality rod ends
- Gold iridited main plate and brackets
- All hardware included
- Lever adjustments for dash and seat clearance
- 360 degree lever rotation for extra leg space
- Teflon®-lined shifter knob buttons for smooth operation
- Easy to remove shifter knobs for simple boot installation
- Available for GM, Ford and Chrysler Automatic Transmissions\*
- Levers available in chrome-plated or black powder coat finish
- Levers available in 6", 8", and 16" bench bend lengths\*
- Choice of round knob in black, white, or brite finish.
- Accessory knobs available separately
- Shifter Boots sold separately
- Available in Nostalgia style.

**\*Please specify transmission type, lever length and knob color when ordering**

*Knobs available in Black, White, or Brite.*



*Engagement design looks and feels like factory GM muscle car shifters of the 1960's.*

**All Ford AOD Shifters  
require the use of a Lokar  
Kickdown Kit.**

Automatic Transmission Shifters



# Lever Style And Length Options

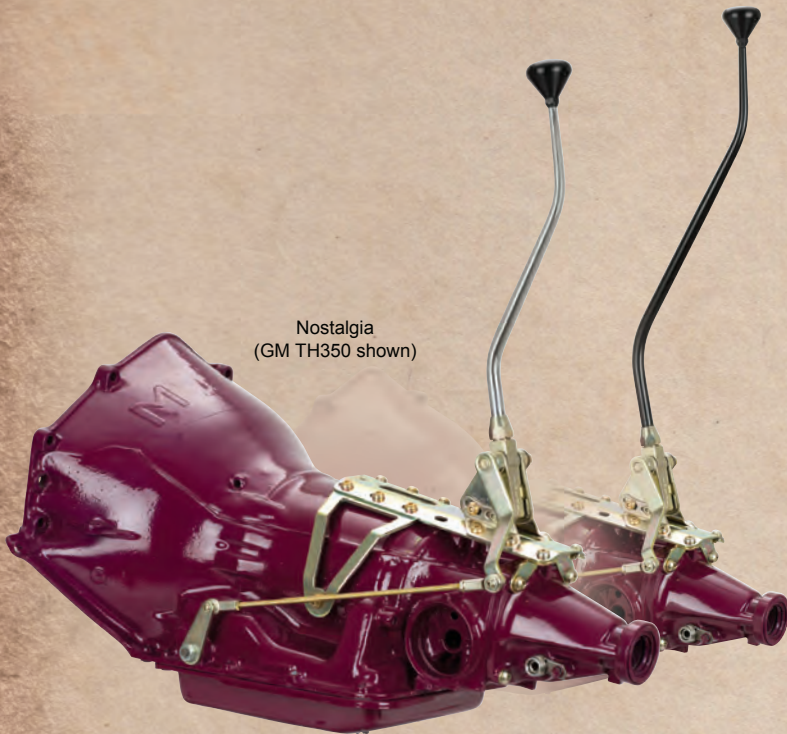

Nostalgia  
(GM TH350 shown)



## 16" BENCH BEND AUTOMATIC TRANSMISSION SHIFTERS

This shifter lends itself to vehicles with bench seats such as pickup trucks and muscle cars. The 16" Bench Bend Shifter is available in our transmission mount, floor mount, tailmount and cable operated shifter applications for GM, Ford, and Chrysler Automatic Transmissions in chrome or black finish.

## NOSTALGIA AND "RADICAL 32" AUTOMATIC TRANSMISSION SHIFTERS

Lokar Nostalgia Shifters are reminiscent of the early days of hot rodding. The classic double bend chromed lever and Black Mushroom knob gives you a "Blast to the Past" and is another exceptional example of Lokar's quality. Available in both 16" and 23" lever lengths and shares all of the same outstanding features of our single bend shifters.

The "Radical 32" Automatic Transmission Shifter provides an amazing 3 feet of shifter at your fingertips! It satisfies the need for extreme, without sacrificing the exceptional features provided in all Lokar shifters. "Radical 32" is available in a classic double bend or our standard single bend chromed lever and is equipped with our Black Mushroom knob.

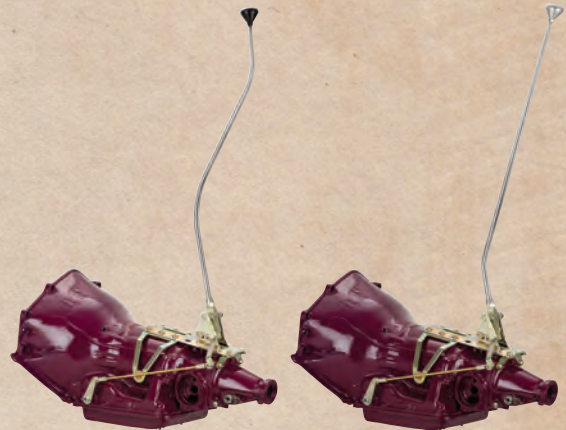

Radical Double Bend

Radical Single Bend

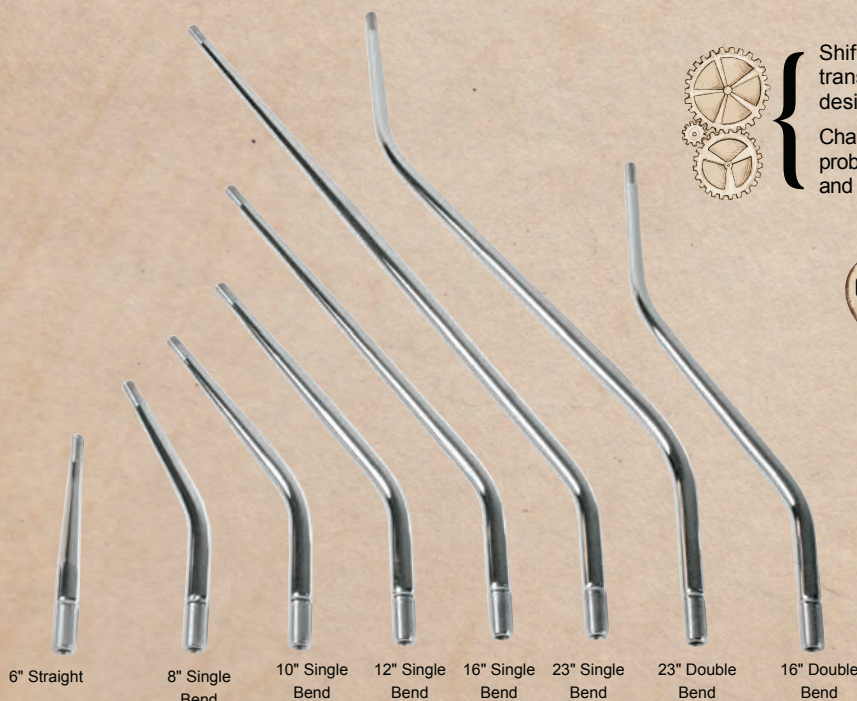

6" Straight

8" Single Bend

10" Single Bend

12" Single Bend

16" Single Bend

23" Single Bend

23" Double Bend

16" Double Bend



Shifter lever lengths start 3-1/2" above the top of the transmission. Use this measurement to determine the desired shifter lever length for your vehicle.

Changing from one type of transmission to another? No problem. Lokar offers Conversion Kits for your convenience and savings. Give us a call for your specific needs.



**ORDERING TIP**

Any shifter lever can be ordered in black using an "X" in front of the part number.



# Identifying The Lokar Shifter

Lokar's precision engineered shifters are available in an almost unlimited number of combinations, ensuring that you can make your build as unique as you want to. To determine the item number for your shifter, use the following guide.

## X ATS 6 350 B M

INDICATES BLACK    SHIFTER TYPE    PRODUCT CATEGORY    TRANS TYPE    LEVER LENGTH    KNOB TYPE

- 1 Specify the make of your car (Ford, GM, Chrysler, etc). Lokar shifters are categorized this way.
- 2 Next, indicate Automatic (ATS), Floor Mount (FMS), Cable Operated (COS), Muscle Car Shifter (MCS), or Electronic Sport Shifter (ESS).
- 3 Then Product Category. '6' indicates it is a shifter.
- 4 Determine the transmission type (350, OC6, etc).
- 5 Then the lever length is listed based on the chart below.
- 6 If this is a Tailmount Shifter, TM is then listed in the product number.
- 7 Finally, the knob type will be listed as determined by the chart below.

Any shifter can be ordered in black by using an 'X' in front of the part number.

If you need additional assistance with selecting your shifter, please phone or email our Tech Department at 877.469.7440 or tech@lokar.com

### LEVER LENGTHS

A=23"  
B=16"  
C=12"  
D=10"  
E=8"  
F=6"

G=16" Bench Bend  
R2=32" Double Bend  
R1=32" Single Bend  
AN=23" Nostalgia  
BN=16" Nostalgia

### KNOBS

M=Mushroom  
MP=Mushroom Polished  
B=Black Anodized Mushroom  
L=Lokar Hi-Tech  
LP=Lokar Polished  
LB=Lokar Black Hi-Tech  
PP=Polished Piston  
P=Piston  
8=Eight Ball  
S=Skull

### FACTORY INSTALLED KNOB OPTIONS

Each Lokar shifter can be ordered with your choice of one of the below knobs at no additional cost. All Nostalgia Shifters, Radical 32", and Black Powder Coated equipped with Black Billet Mushroom Knobs unless otherwise specified when ordering.



**M** Original Brushed Billet Aluminum Mushroom



**B** Black Billet Aluminum Mushroom



**L** Hi-Tech Lokar Brushed Billet Aluminum



**LB** Black High-Tech Lokar Billet Aluminum

### TRANSMISSION IDENTIFICATION

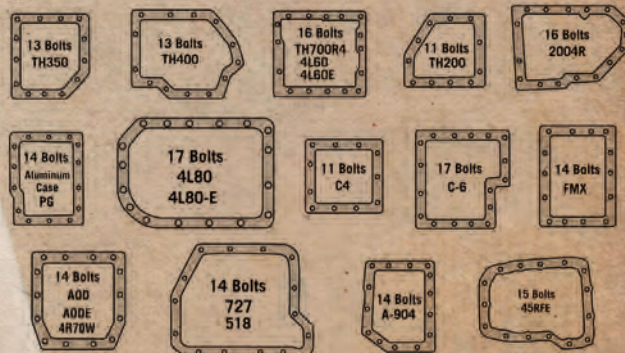

All Ford AOD Shifters require the use of a Lokar Kickdown Kit.

NOTE: All Powerglide Shifters are designed for aluminum cases only - cast iron not available.



# Lokar Aluminum Shifter Knobs

Smooth operation is guaranteed with our Safety Lock-Out Teflon®-lined button. These easy-to-remove shifter knobs have been designed for simple boot installation. Specify transmission type when ordering to ensure the correct shift pattern\* is provided. Knobs operate with Lokar Shifters only.

\* Engraved shift pattern on knob meets NSRA safety requirements.



PART NO.	DESCRIPTION
SK-6838	3-Speed Automatic Brushed Mushroom Knob
SK-6839	3-Speed Automatic Black Mushroom Knob
SK-6840	3-Speed Automatic Brushed Lokar Knob
SK-6904	3-Speed Automatic Black Lokar Knob
SK-6841	GM 4-Speed Overdrive Brushed Mushroom Knob
SK-6842	GM 4-Speed Overdrive Black Mushroom Knob
SK-6843	GM 4-Speed Overdrive Brushed Lokar Knob
SK-6906	GM 4-Speed Overdrive Black Lokar Knob
SK-6844	Powerglide Brushed Mushroom Knob
SK-6845	Powerglide Black Mushroom Knob
SK-6846	Powerglide Brushed Lokar Knob
SK-6909	Powerglide Black Lokar Knob
SK-6847	Ford AOD, 4R70W, AODE Brushed Mushroom Knob
SK-6848	Ford AOD, 4R70W, AODE Black Mushroom Knob
SK-6849	Ford AOD, 4R70W, AODE Brushed Lokar Knob
SK-6908	Ford AOD, 4R70W, AODE Black Lokar Knob

## PREMIUM LOKAR ALUMINUM SHIFTER KNOBS

All Premium Shifter Knobs are designed with our Safety Lock-Out Teflon® lined button and function with the same smooth operation as our original factory installed knobs. All Premium Shifter Knobs are available with a plain button. Engraved shift pattern available on button for skull and piston knobs. \*8-Ball Shifter Knob is machined from Delrin® and is not available with an engraved shift pattern. Premium Knobs operate with Lokar Shifters only.

### PISTON KNOBS

PART NO.	DESCRIPTION
SK-6857	3-Speed Piston Knob – Polished
SK-6856	GM 4-Speed Overdrive Piston Knob – Polished
SK-6859	Ford AOD, 4R70W, AODE Piston Knob – Polished
SK-6858	Powerglide Piston Knob – Polished
SK-6851	3-Speed Piston Knob – Brushed
SK-6852	GM 4-Speed Overdrive Piston Knob – Brushed
SK-6854	Ford AOD, 4R70W, AODE Piston Knob – Brushed
SK-6853	Powerglide Piston Knob – Brushed

### SKULL KNOBS

SK-6862	3-Speed Skull Knob – Polished
SK-6863	GM 4-Speed Overdrive Skull Knob – Polished
SK-6865	Ford AOD, 4R70W, AODE Skull Knob – Polished
SK-6864	Powerglide Skull Knob – Polished
SK-6861	Skull Knob w/Plain Button – Polished

### MUSHROOM KNOBS

SK-6860	3-Speed Auto Mushroom Knob – Polished
SK-6855	GM 4-Speed Overdrive Mushroom Knob – Polished
SK-6887	Ford AOD, 4R70W, AODE Mushroom Knob – Polished
SK-6880	Powerglide Mushroom Knob – Polished

### LOKAR HI-TECH SHIFT KNOB

SK-6867	3-Speed Lokar Knob – Polished
SK-6905	GM 4-Speed Overdrive Lokar Knob – Polished
SK-6907	Ford AOD, 4R70W, AODE Lokar Knob – Polished
SK-6850	8-Ball Shifter Knob

### PREMIUM LOKAR ALUMINUM SHIFT KNOBS

SK-6920	2" Solid Round Satin Shift Knob w/Plain Button
SK-6921	2" Solid Round Black Shift Knob w/Plain Button
SK-6922	2" Solid Round Polished Shift Knob w/Plain Button
SK-6923	2" Venetian Satin Shift Knob with Plain Button
SK-6924	2" Venetian Black Shift Knob with Plain Button
SK-6925	2" Venetian Polished Shift Knob with Plain Button
SK-6926	2" Deco Satin Shift Knob with Plain Button
SK-6927	2" Deco Black Shift Knob with Plain Button
SK-6928	2" Deco Polished Shift Knob with Plain Button



2" Deco Shift Knobs with Plain Button



2" Solid Shift Knobs with Plain Button



2" Venetian Shift Knobs with Plain Button



Plain buttons available



# Lokar Shifter Knob Adapters

Shifter Knobs & Adapters

While personal style is important, at Lokar "Safety is Never an Extravagance."

To fill the void between personal preference and personal safety, Lokar developed a Shifter Knob Adapter which allows you to express yourself with highly custom knobs, yet still retain all of the safety features and benefits of a Lokar Shifter, including the positive lock-out in Park and Neutral. (See page 2 for all the safety features of our shifters)

After thoughtful consideration and careful planning, Lokar invented a Shifter Knob Adapter with hidden functional parts and a sleek design which will install on ANY Lokar Shifter without modification and allow the use of virtually anything as a knob.

The Adapter is offered with common 3/8"-16 or 3/8"-24 thread sizes and is available in either a chrome or black finish. We also offer a muscle car shifter knob adapter to replicate the feel of an original muscle car shifter.

PART NO.	DESCRIPTION
SK-6878	Shifter Knob Adapter for 3/8"-16 Knob
XSK-6878	Black Shifter Knob Adapter for 3/8"-16 Knob
SK-6879	Shifter Knob Adapter for 3/8"-24 Knob
XSK-6879	Black Shifter Knob Adapter for 3/8"-24 Knob
SK-68MCB	Shift Knob Adapter with Black Muscle Car Knob
SK-68MCT	Shift Knob Adapter with Brite Muscle Car Knob
SK-68MCW	Shift Knob Adapter with White Muscle Car Knob



Muscle Car Shifter Knob Adapter

Black, White, and Polished Knobs Available.



## KNOB FOR LOKAR SHIFTER KNOB ADAPTER

- Offered in 2-1/4" diameter
- Plain design (no shift pattern)

PART NO.	DESCRIPTION
SK-6882	*2-1/4" Plain Ivory Shift Knob 3/8"-16 & 3/8"-24
SK-6883	*2-1/4" Plain White Shift Knob 3/8"-16 & 3/8"-24
SK-6884	*2-1/4" Plain Black Shift Knob 3/8"-16 & 3/8"-24
SK-6885	*2-1/4" Black 8-Ball Shift Knob 3/8"-16 & 3/8"-24
SK-6886	*2-1/4" Ivory & Red 8-Ball Shift Knob 3/8"-16 & 3/8"-24
SK-6888	*2-1/4" Transparent Red Flamed Shift Knob 3/8"-16 & 3/8"-24
SK-6912	2" Solid Round Satin Shift Knob 3/8" -24 Thread
SK-6913	2" Solid Round Black Shift Knob 3/8" -24 Thread
SK-6914	2" Solid Round Polished Shift Knob 3/8" -24 Thread
SK-6918	2" Venetian Satin Shift Knob 3/8" -24 Thread
SK-6916	2" Venetian Black Shift Knob 3/8" -24 Thread
SK-6919	2" Venetian Polished Shift Knob 3/8" -24 Thread

\*Includes aluminum 3/8"-16 & 3/8"-24 thread inserts and polished jam nuts.

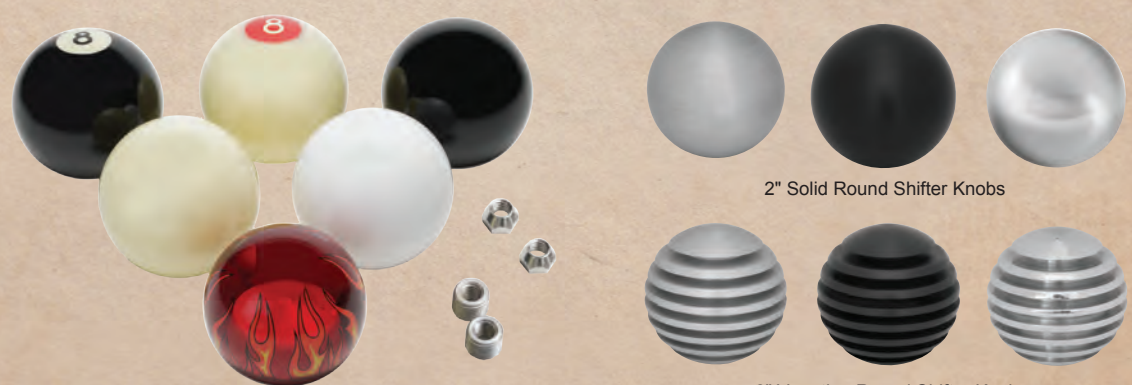

2 1/4" Shifter Knobs

2" Solid Round Shifter Knobs

2" Venetian Round Shifter Knobs





(GM TH350 shown)

# Column Cable Shift Linkage

Lokar's Column Cable Shift Linkage is the ultimate answer to interference issues when you are unable to use factory or Lokar's hard column linkage. The flexibility of the cable allows you to route it around the transmission, cross-members, and brake pedals. Our exclusive Billet Aluminum Mounting Arm can be used on either side of the column. Lokar's Column Cable Shift Kit allows you to use our shift indicator kits. It can also be used in conjunction with our Back-Up Light or Neutral Safety Switch Kit (BL-1400U) for most GM Transmissions. Available in black housing, designed with specially extruded liner for extended life of the cable, and stainless inner wire measuring 6 feet in length. Ready-to-install hardware and brackets included in kit – no cutting or measuring – simply bolts on. Longer cables are available upon request.

\*Kits are available for TH350, TH400, 700-R4, TH200, 200-4R, 4L60 and 4L80E (short selector shaft only).

PART NO.	DESCRIPTION
ACA-1804	2" aftermarket GM style columns and most GM factory columns*
ACA-1805	2 1/4" aftermarket columns*

\*For all GM Transmissions except Powerglide, 4L60E, 4L70E, and newer transmissions. Does not fit Ford or Chrysler Transmissions.



If you have a direct line of sight from column shift arm to transmission shift arm, we suggest using our adjustable column shift linkage. (See page 11). To determine column diameter, measure the lower outer column tube.

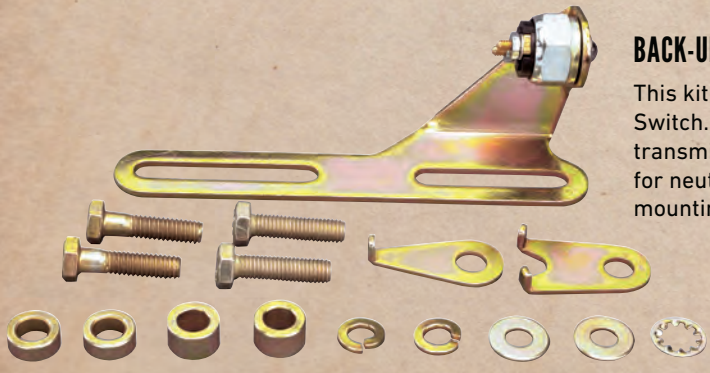

## BACK-UP LIGHT OR NEUTRAL SAFETY SWITCH KIT

This kit offers the choice of Back-Up Light Switch OR Neutral Safety Switch. Fits TH350, TH400, 700-R4, TH200, 200-4R, and 4L60 transmissions. Single trigger for back-up light switch, or double trigger for neutral safety switch. KIT WILL NOT PERFORM BOTH FUNCTIONS. All mounting hardware included.

PART NO.	DESCRIPTION
BL-1400U	Back-Up Light or Neutral Safety Switch Kit TH350, TH400, 700-R4, TH200, 200-4R, and 4L60



## GM & FORD C4/C6 ADJUSTABLE COLUMN SHIFT LINKAGE

Simplify connecting your column shift to your transmission with a Lokar machined billet aluminum Adjustable Column Shift Linkage Kit. Works with all GM style factory or aftermarket columns. Our rigid, clean line design allows the proper ratio adjustment between the transmission and the indicator on the column.

### FEATURES

- Billet aluminum offers rigidity
- 3/4"-48 spline designed for 360° rotation allowing proper ratio
- Both 3/8"-16 and M10x1.5 threaded nuts for mounting electrical accessories
- Kit includes all hardware, including column bushing and rod ends
- "U-Cut-to-Fit" Stainless Connecting Rod
- Stainless steel connecting rod can be bent for clearance around some obstacles
- No threading necessary
- Fits GM TH350, TH400, 700-R4, TH200, 200-4R, 4L60, 4L60E and 4L80E transmissions
- Fits Ford C4 and C6 transmissions
- Aluminum Adjustable Trans Shift Arms also sold separately

PART NO.	DESCRIPTION
ACA-1800	Adjustable Column Shift Linkage TH350, TH400, 700-R4, TH200, 200-4R, 4L60, 4L60E and 4L80E
ACA-1801	Adjustable Column Shift Linkage Ford C4/C6
ACA-1809	Adjustable Column Shift Linkage GM 6L80



GM Adjustable Billet Column Arm Kit



**ORDERING TIP** You can use our BL-1400U Backup-Light or Neutral Safety Switch Kit with GM Column Shift Linkage, except for 400, 700R, 4L60E, and 4L80E transmissions.



If you don't have a direct line of sight between the column shift arm and the transmission shift arm, consider using a column cable shift linkage (See page 10) with the Tailmount, Floor Mount, and Cable Operated Shifters.

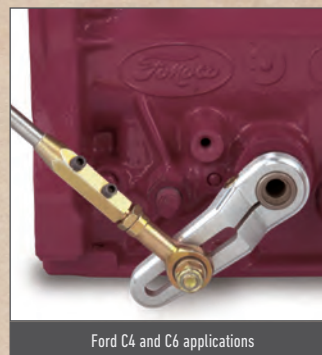

Ford C4 and C6 applications

GM TH350, TH400, 700-R4, TH200, 200-4R, 4L60, 4L60E and 4L80E applications

## FORD AOD/4R70W/AODE ADJUSTABLE COLUMN SHIFT LINKAGE

### FEATURES

- Works with GM style factory or aftermarket columns
- Allows proper ratio adjustment between transmission and indicator on the column
- Kit includes Lokar AOD or 4R70W/AODE Selector Shaft and Arm
- Kit includes all hardware, including bushings and rod ends
- "U-Cut-to-Fit" stainless steel connecting rod
- Stainless steel connecting rod can be bent for clearance around some obstacles
- No threading necessary
- All steel parts are zinc plated
- AOD Selector Shaft and Arm also available separately (See page 12)

PART NO.	DESCRIPTION
ACA-1807	Ford AOD Adjustable Column Shift Linkage
ACA-1808	Ford 4R70W/AODE Adjustable Column Shift Linkage



(Ford AOD shown)

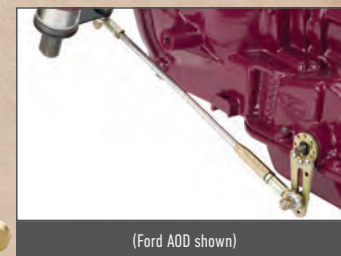



# Automatic Transmission Accessory Parts

## FORD AOD SELECTOR SHAFT AND ARM

Lokar's Ford AOD Selector Shaft and Arm is the solution to hunting for the right part. By standardizing the shift linkage for aftermarket applications, Lokar has eliminated the guess work, saving you time and money. This fully adjustable shaft and arm finally allows for installation on numerous applications.

### FEATURES

- Replaces factory selector shaft and arm
- Adjustable arm simplifies finding the proper ratio between the shifter and the transmission
- Arm designed to be installed in any 360 degree position for versatility
- Kickdown seal installed in selector shaft
- Zinc plated with stainless steel hardware
- Can be used with many aftermarket shifters
- Detailed instructions

All Ford AOD Shifters require the use of a Lokar Kickdown Kit.

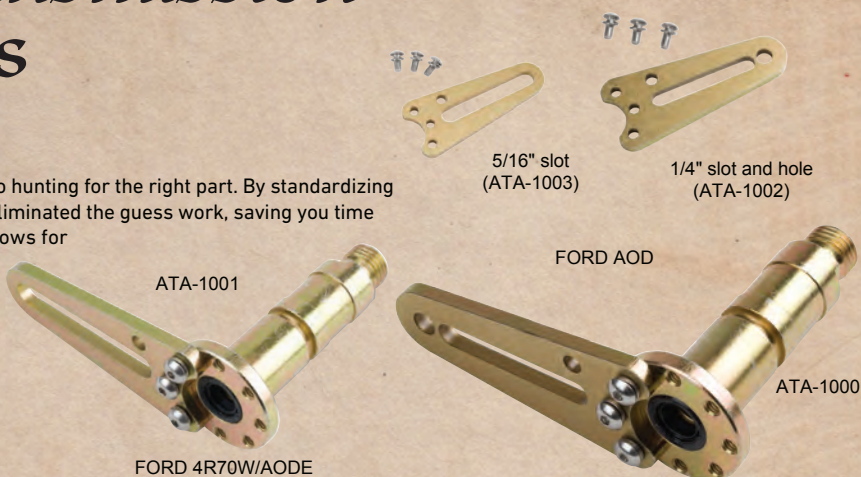

### PART NO. DESCRIPTION

PART NO.	DESCRIPTION
ATA-1000	Ford AOD Selector Shaft and Arm 1/4" slot and hole
ATA-1001	Ford AOD Selector Shaft and Arm 5/16" slot
ATA-1002	Ford 4R70W/AODE Selector Flange and Arm 1/4" slot and hole
ATA-1003	Ford 4R70W/AODE Selector Flange and Arm 5/16" slot
ATA-1004	Ford 4R70W/AODE Selector Shaft, Flange and Arm 1/4" slot and hole
ATA-1005	Ford 4R70W/AODE Selector Shaft, Flange & Arm 5/16" slot



## BILLET ALUMINUM ADJUSTABLE TRANS SHIFT ARMS

### PART NO. DESCRIPTION

ACA-1802	Billet Aluminum Adjustable Trans Shift Arm Only TH350, TH400, 700-R4, TH200, 200-4R, 4L60, 4L60E and 4L80E
ACA-1803	Billet Aluminum Adjustable Trans Shift Arm Only Ford C4/C6
ACA-1810	Billet Aluminum Adjustable Trans Shift Arm Only GM 6L80

ACA-1802  
GM TH350, TH400,  
700-R4, TH200,  
200-4R, 4L60,  
4L60E and 4L80E



## LEVER CONVERSION KITS

DESCRIPTION	CHROME	BLACK POWDER COATED
23" Shifter Lever & Inner Rod	S-68144	XS-68144
23" Nostalgia Shifter Lever & Inner Rod	S-68145	XS-68145
16" Shifter Lever & Inner Rod	S-68146	XS-68146
16" Nostalgia Shifter Lever & Inner Rod	S-68147	XS-68147
12" Shifter Lever & Inner Rod	S-68148	XS-68148
10" Shifter Lever & Inner Rod	S-68149	XS-68149
8" Shifter Lever & Inner Rod	S-68150	XS-68150
6" Shifter Lever & Inner Rod	S-68151	XS-68151
32" Single Bend Shifter Lever & Inner Rod	S-68152	XS-68152
32" Double Bend Shifter Lever & Inner Rod	S-68153	XS-68153
16" Bench Bend Shifter Lever & Inner Rod	S-68188	XS-68188



## SPARE SHIFTER SHIFTER COMPONENT PARTS



Rod Ends 5/16" - 24 and  
1/4" - 28  
(Sold in Pairs)  
Part # S-68155 1/4" - 28  
Part # S-68156 5/16" - 24



# Electronic Shifters

## AUTOMATIC ELECTRONIC SPORT MODE SHIFTER

Lokar's new electronic sport mode shifter allows you to take control of your automatic transmission whenever you desire. Just shift your lever from overdrive into sport mode and begin bumping through the gears. With this new shifter Lokar has maintained all of the safety features from our traditional automatic transmission shifters.

### FEATURES

- Positive Lock-out in Park & Neutral
- Neutral Safety Switch
- Floor Mount Design, Cable Operated
- Standard Automatic with integrated "Sport Shift" Mode
- Integrated Lokar indicator sensor output
- Works with all current Lokar Knobs & Adapters
- Available in lever lengths of 6", 8", 10", 12", 16", and 16" Nostalgia
- Applications: 6L80, 6R80, 4L80, 4L60E, AOD, and 4R70W
- Works with most aftermarket controllers

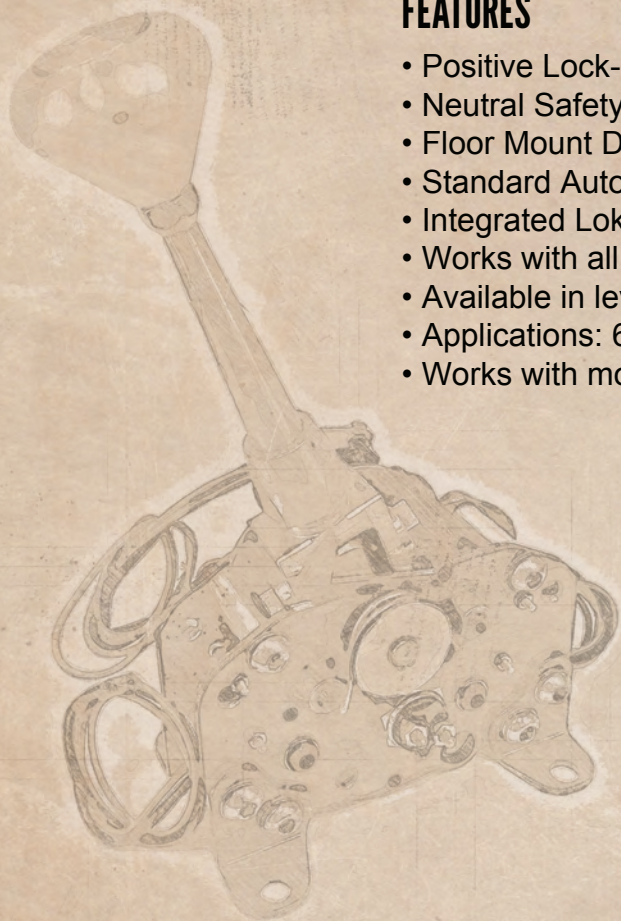

P  
R  
N  
D — S  
UP  
↑  
DOWN  
↓



Sport Mode Shifter does not include boot & ring. Please see page 16 for Boots, Rings & Bezels.



# Manual Transmission Accessories

## MANUAL TRANSMISSION SHIFTER KNOBS

Shifter knobs for 4-Speed, 5-Speed and 6-Speed manual transmissions are 2" in diameter and include 3/8"-24 and 3/8"-16 thread and polished jam nuts. Engraved with appropriate shift pattern, they are available in Ivory, Black and White. A perfect addition to the Lokar Manual Transmission Shifter Levers.

PART NO.	DESCRIPTION
SK-6890	4-Speed Ivory 2" Shift Knob 3/8"-24 & 3/8"-16 Thread Reverse Down Left
SK-6891	4-Speed White 2" Shift Knob 3/8"-24 & 3/8"-16 Thread Reverse Down Left
SK-6892	4-Speed Black 2" Shift Knob 3/8"-24 & 3/8"-16 Thread Reverse Down Left
SK-6893	4-Speed Ivory 2" Shift Knob 3/8"-24 & 3/8"-16 Thread Reverse Up Left
SK-6894	4-Speed White 2" Shift Knob 3/8"-24 & 3/8"-16 Thread Reverse Up Left
SK-6895	4-Speed Black 2" Shift Knob 3/8"-24 & 3/8"-16 Thread Reverse Up Left
SK-6872	5-Speed Ivory 2" Shift Knob 3/8"-24 & 3/8"-16 Thread
SK-6873	6-Speed Ivory 2" Shift Knob 3/8"-24 & 3/8"-16 Thread
SK-6874	5-Speed White 2" Shift Knob 3/8"-24 & 3/8"-16 Thread
SK-6875	6-Speed White 2" Shift Knob 3/8"-24 & 3/8"-16 Thread
SK-6876	5-Speed Black 2" Shift Knob 3/8"-24 & 3/8"-16 Thread
SK-6877	6-Speed Black 2" Shift Knob 3/8"-24 & 3/8"-16 Thread



## CHEVROLET/GMC S-10 5-SPEED MANUAL SHIFT LEVER ADAPTER

### FEATURES

- Replaces factory shifter to adapt to Lokar Manual Shift Lever
- Uses existing factory internal parts
- Fits 1993-2003 NV 3500 Transmission as well as 1995-2003 NV 1500 Transmission
- Requires use of Lokar's T5 Tremec lever
- Fits Lokar's 16", 12", 10" single bend, 16" double bend Tremec levers, and T5 Billet levers offering a variety of lever lengths and knob choices

PART NO.	DESCRIPTION
MSL610	Manual Shift Lever Adapter
MSL605C	Chrome 12" S10 Lever And Manual Shift Lever Adapter

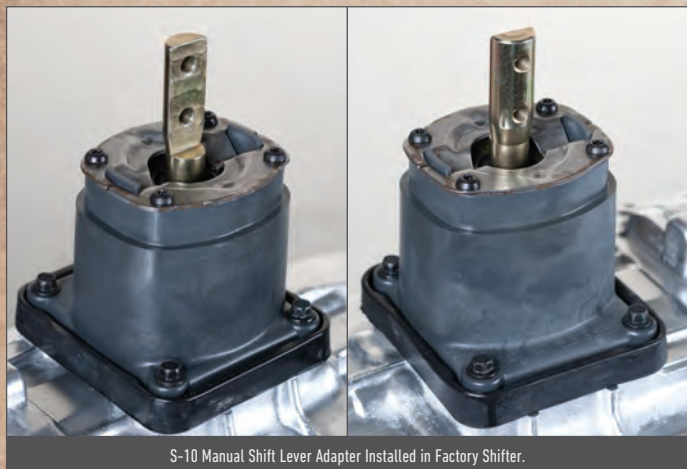

S-10 Manual Shift Lever Adapter Installed in Factory Shifter.

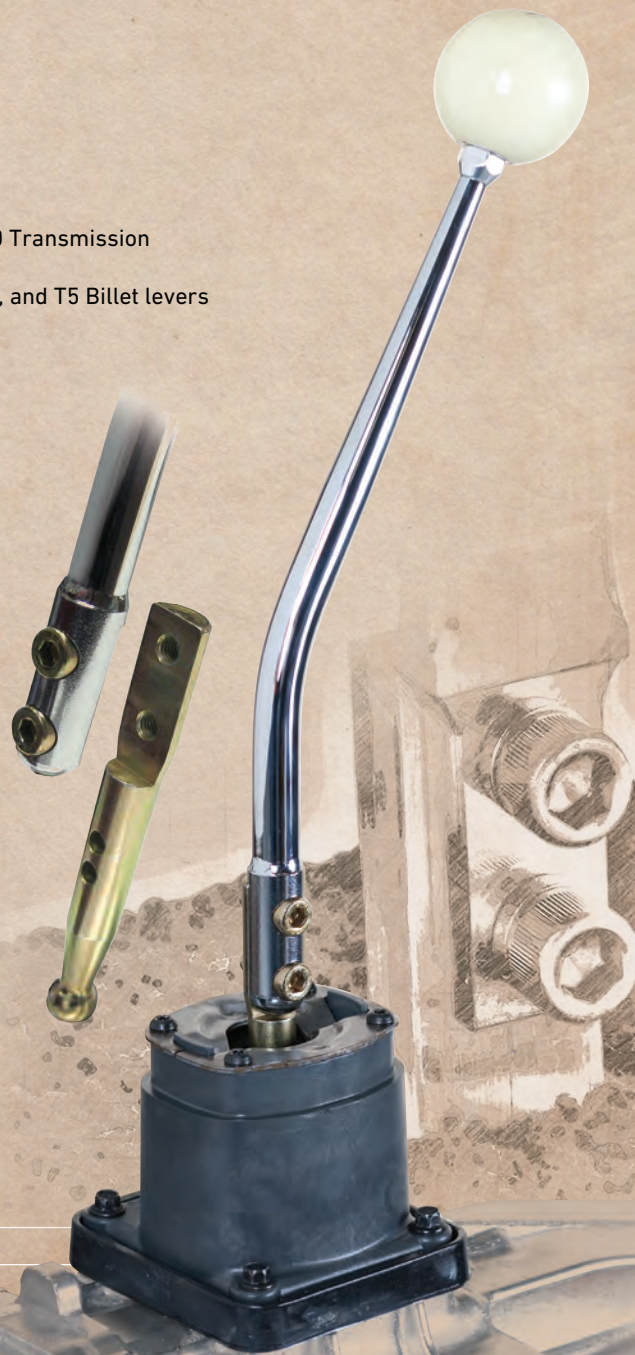





Boot Shown:  
70-BFS

## BILLET ALUMINUM TREMEC/BORG WARNER SHIFTER LEVERS

Direct bolt on billet aluminum shifter levers. These levers will fit the Tremec T5, T45, T56 and TKO manual transmissions with the standard 2-bolt flange and give you that clean, smooth appearance.

**Voted Runner Up 2011 SEMA Show Best New Interior Accessory Product.**

- Billet Aluminum construction
- Windowed levers complement other Lokar products
- Unique styling
- Machined groove for boot attachment
- 3/8"-16 Thread for shift knob
- Mounting hardware included
- Available in 6" and 8" straight and also available in 6", 8" and 10" with a single bend.
- Brushed or black finish
- Rings Purchased Separately (See Page 16)

PART NO.	DESCRIPTION
MSL611D	Billet Aluminum TKO 500-600 & Magnum Manual Shift Lever 10"
XMSL611D	Black Billet Aluminum TKO 500-600 & Magnum Manual Shift Lever 10"
MSL612E	Billet Aluminum TKO 500-600 & Magnum Manual Shift Lever 8"
XMSL612E	Black Billet Aluminum TKO 500-600 & Magnum Manual Shift Lever 8"
MSL613E	Billet Aluminum TKO 500-600 & Magnum Manual Shift Lever 8" Straight
XMSL613E	Black Billet Aluminum TKO 500-600 & Magnum Manual Shift Lever 8" Straight
MSL614F	Billet Aluminum TKO-500-600 & Magnum Manual Shift Lever 6"
XMSL614F	Black Billet Aluminum TKO-500-600 & Magnum Manual Shift Lever 6"
MSL615F	Billet Aluminum TKO 500-600 & Magnum Manual Shift Lever 6" Straight
XMSL615F	Black Billet Aluminum TKO 500-600 & Magnum Manual Shift Lever 6" Straight
MSL616D	Billet Aluminum Tremec/Borg Warner T5, T45, T56 Shift Lever 10"
XMSL616D	Black Billet Aluminum Tremec/Borg Warner T5, T45, T56 Shift Lever 10"

PART NO.	DESCRIPTION
MSL617E	Billet Aluminum Tremec/Borg Warner T5, T45, T56 Shift Lever 8"
XMSL617E	Black Billet Aluminum Tremec/Borg Warner T5, T45, T56 Shift Lever 8"
MSL618E	Billet Aluminum Tremec/Borg Warner T5, T45, T56 Shift Lever 8" Straight
XMSL618E	Black Billet Aluminum Tremec/Borg Warner T5, T45, T56 Shift Lever 8" Straight
MSL619F	Billet Aluminum Tremec/Borg Warner T5, T45, T56 Shift Lever 6"
XMSL619F	Black Billet Aluminum Tremec/Borg Warner T5, T45, T56 Shift Lever 6"
MSL620F	Billet Aluminum Tremec/Borg Warner T5, T45, T56 Shift Lever 6" Straight
XMSL620F	Black Billet Aluminum Tremec/Borg Warner T5, T45, T56 Shift Lever 6" Straight

### TREMEC BOOTS

- 70-SRB Round Tremec Boot for Billet Aluminum Levers
- 70-BFS Floormount Tremec Boot for Billet Aluminum Levers



Designed to compliment Goolsby by Lokar Edition product on pages 23 and 59.

## GOOLSBY EDITION BY LOKAR SHIFTER LEVERS

The Goolsby Edition by Lokar Billet Aluminum Shift Lever is direct bolt on for the Tremec T5, T45, T56 and TKO Transmissions. Made of durable billet aluminum construction. The lever, available in brushed or polished finish, features a machined groove for boot attachment. All mounting hardware is included.

PART NO.	DESCRIPTION
MSL621D	Goolsby Edition Billet Aluminum Tremec TKO 500-600 Shift Lever 10" - Polished
XMSL621D	Goolsby Edition Billet Aluminum Tremec TKO 500-600 Shift Lever 10" - Black
MSL622D	Goolsby Edition Billet Aluminum Borg Warner T5, T45, T56 Shift Lever 10" - Polished
XMSL622D	Goolsby Edition Billet Aluminum Borg Warner T5, T45, T56 Shift Lever 10" - Black

## MANUAL TRANSMISSION SHIFTER LEVERS

Direct bolt on tubular shifter levers for Tremec/Borg Warner manual transmissions are built for stock and aftermarket 5 and 6 speed shifters. They fit the TKO, T5, T45, and T56 with the standard 2-bolt flange measuring 7/8" center to center. To give you a clean, smooth appearance, these levers feature a machined billet steel mounting stud counter sunk for cap screws. Tremec/Borg Warner kits include 8mm socket head cap screws and Tremec TKO includes 3/8"-24 socket head cap screws. Levers feature a 3/8"-24 thread for the shift knob and are available in 16", 12", and 10" lengths with a single bend. The 16" lever is also available in a double bend. All levers are available in chrome or black finish.

DESCRIPTION	CHROME	BLACK POWDER COATED
Tremec/Borg Warner, T5, T45, T56 Shift Lever 16"	MSL6B	XMSL6B
Tremec/Borg Warner, T5, T45, T56 Shift Lever 12"	MSL6C	XMSL6C
Tremec/Borg Warner, T5, T45, T56 Shift Lever 10"	MSL6D	XMSL6D
Tremec/Borg Warner, T5, T45, T56 Shift Lever 16" Double Bend	MSL6B2	XMSL6B2
Tremec TKO 500 - 600 & Magnum Shift Lever 16"	MSL601B	XMSL601B
Tremec TKO 500 - 600 & Magnum Shift Lever 12"	MSL602C	XMSL602C
Tremec TKO 500 - 600 & Magnum Shift Lever 10"	MSL603D	XMSL603D
Tremec TKO 500 - 600 & Magnum Shift Lever 16" Double Bend	MSL604B2	XMSL604B2

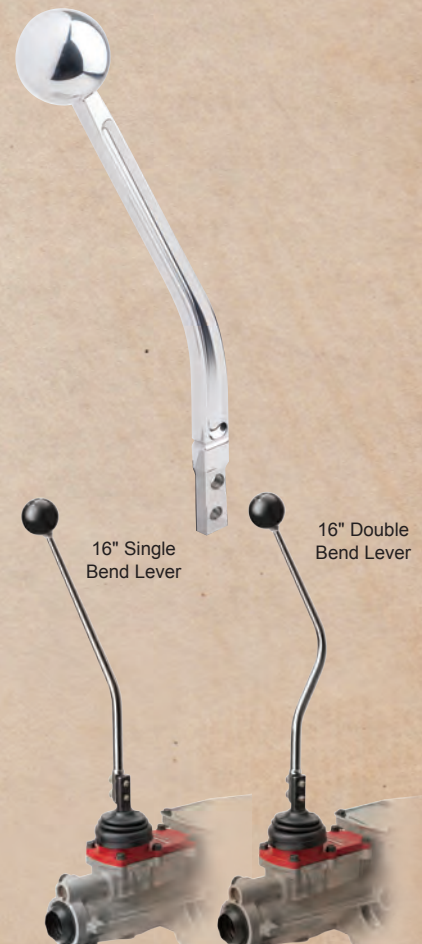



# Shifter Boots, Bezels & Ring Sets

## SHIFTER BOOT AND RING SETS

Lokar Shifter Boots are made of black Naugahyde. All sets include a boot, stainless base ring, or billet aluminum ring with ball-milled edge and stainless screws. Stainless boot rings are available in polished stainless or black powder coat. Aluminum boot rings are available in brushed aluminum or black anodized finish.

Our Classic Shifter Boot is designed with a polished stainless bezel on top of the boot which fits over the shifter lever. It also includes a foam rubber seal to eliminate air flow from the floor through the boot.

All boots hug the shifter lever and there are no unsightly pull ties or laces.

### BOOT RING DIMENSIONS

DESCRIPTION	OUTER DIMENSION	INNER DIMENSION
Stainless Round Shifter Boot Ring	5"	4"
Billet Aluminum Round Shifter Boot Ring	5-1/4"	4"
Stainless Rectangular Floor Mount Shifter Boot Ring	6-3/4" x 5-1/4"	5-1/2" x 4"
Billet Aluminum Rectangular Floor Mount Shifter Boot Ring	6-3/4" x 5-1/4"	5-1/2" x 4"

### SHIFTER BOOT AND HAND BRAKE BOOT KITS

DESCRIPTION	STAINLESS RING	BILLET RING	BLACK ANODIZED ALUMINUM RING	BLACK STAINLESS RING
Classic Shifter Boot	70-CLB	70-BCLB	X70-BCLB	X70-CLB
Hot Rod Shifter Boot	70-HRB	70-BHRB	X70-BHRB	X70-HRB
Rectangular Floor Mount Shifter Boot	70-FMB	70-BFMB	X70-BFMB	X70-FMB

#### BOOT RINGS ONLY (includes stainless screws)

DESCRIPTION	STAINLESS RING	BILLET RING	BLACK ANODIZED ALUMINUM RING	BLACK STAINLESS RING
Round Shifter Boot Ring	70-SSR	70-BSR	X70-BSR	X70-SSR
Rectangular Shifter Boot Ring	70-SFR	70-BFR	X70-BFR	X70-SFR



Black Hot Rod Shifter Boot with Ring • Part # X70-HRB



Black Classic Shifter Boot with Ring Part # X70-CLB



Black Rectangular Floor Mount Shifter Boot with Ring Part # X70-FMB



Black Billet Rectangular Shifter Boot Ring with Boot Part # X70-BFMB



Billet Rectangular Floor Mount Shifter Boot Ring with Boot 70-BFMB



Rectangular Floor Mount Shifter Boot with Ring 70-FMB



Classic Shifter Boot with Ring 70-CLB



Hot Rod Shifter Boot with Ring 70-HRB



Hot Rod Shifter Boot with Billet Ring 70-BHRB



Get a matching handbrake boot. (See Page 29)



## HI-TOP SHIFTER BOOTS

Hi-Top Shifter Boots and Bezels complement any interior to produce a sporty modern appearance. These Boots are designed with a choice of threaded Bezels that attach to the top of the shifter lever threads, doubling as a jam nut and completely concealing the shifter lever. Receiver groove for easy boot attachment. Available in 3/8"-24 and 3/8"-16 threads. Boots cover an entire 6" and 8" Lokar Shifter Lever. Boots available for round or rectangular boot rings (sold separately). Bezels available in Brushed, Black and Chrome finish.

PART NO.	DESCRIPTION
70-BAR1	Hi-Top Round Boot w/Billet Aluminum Bezel 3/8"-24 Thread
70-BAR2	Hi-Top Round Boot w/Billet Aluminum Bezel 3/8"-16 Thread
70-BAF1	Hi-Top Rectangular Boot w/Billet Aluminum Bezel 3/8"-24 Thread
70-BAF2	Hi-Top Rectangular Boot w/Billet Aluminum Bezel 3/8"-16 Thread
X70-BAR1	Black Hi-Top Round Boot w/Billet Aluminum Bezel 3/8"-24 Thread
X70-BAR2	Black Hi-Top Round Boot w/Billet Aluminum Bezel 3/8"-16 Thread
X70-BAF1	Black Hi-Top Rectangular Boot w/Billet Aluminum Bezel 3/8"-24 Thread
X70-BAF2	Black Hi-Top Rectangular Boot w/Billet Aluminum Bezel 3/8"-16 Thread
70-CR1	Chrome Hi-Top Round Boot with Bezel 3/8"-24 Thread
70-CR2	Chrome Hi-Top Round Boot with Bezel 3/8"-16 Thread
70-CF1	Chrome Hi-Top Rectangular Boot with Bezel 3/8"-24 Thread
70-CF2	Chrome Hi-Top Rectangular Boot with Bezel 3/8"-16 Thread
70-BAB1	Billet Aluminum Boot Bezel 3/8"-24 Thread
70-BAB2	Billet Aluminum Boot Bezel 3/8"-16 Thread
X70-BAB1	Black Billet Aluminum Boot Bezel 3/8"-24 Thread
X70-BAB2	Black Billet Aluminum Boot Bezel 3/8"-16 Thread
70-CBB1	Chrome Boot Bezel 3/8"-24 Thread
70-CBB2	Chrome Boot Bezel 3/8"-16 Thread



Hi-Top Shifter Boot  
(Boot Rings sold separately)



## DELUXE TOP SHIFTER BOOTS

Deluxe Top Shifter Boots and Sliding Bezels with O-Ring complement any interior to produce a sporty modern appearance. These Boots are designed with a choice of Sliding Bezels with O-Ring so that the boot can be placed anywhere along the length of the shifter lever, allowing a portion of the lever to be exposed. Receiver groove for easy boot attachment. Sliding Bezel is designed for a 5/8" shifter lever. Works with any lever length for personal preference. Boots available for round or rectangular boot rings (sold separately). Sliding Bezels with O-Ring available in Brushed, Black and Chrome finish.

PART NO.	DESCRIPTION
70-BAR3	Deluxe Top Round Boot with 5/8" Billet Aluminum Sliding Bezel
70-BAF3	Deluxe Top Rectangular Boot with 5/8" Billet Aluminum Sliding Bezel
X70-BAR3	Black Deluxe Top Round Boot with 5/8" Billet Aluminum Sliding Bezel
X70-BAF3	Black Deluxe Rectangular Boot with 5/8" Billet Aluminum Sliding Bezel
70-CR3	Chrome Deluxe Top Round Boot with 5/8" Sliding Bezel
70-CF3	Chrome Deluxe Top Rectangular Boot with 5/8" Sliding Bezel
70-BAB3	Billet Aluminum Boot Bezel 5/8" Sliding Bezel
X70-BAB3	Black Billet Aluminum Boot Bezel 5/8" Sliding Bezel
70-CBB3	Chrome Boot Bezel 5/8" Sliding Bezel



Deluxe Top Shifter Boot  
(Boot Rings sold separately)





# Shift Indicators & Sensor Kits

## LED BOOT & DASH INDICATORS

Make sure you know where you transmission is at any given time with our LED Shift Indicator. LED Shift Indicators are designed to work with our cable operated sensor kits (see page 20). They also go great with any shifter using a solid or premium decorative knob without a shift pattern.

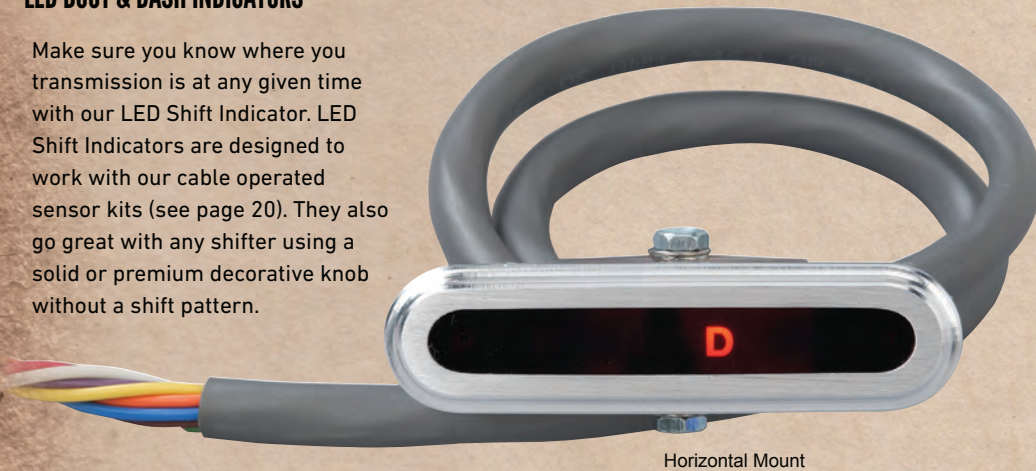

Horizontal Mount



Vertical Mount

### FEATURES

- Long Life LED Indicators
- Displays transmission position in engaged gear only
- Displays available in horizontal and vertical
- Mount available in boot mount or dash mount
- Each Gear Illuminates When Engaged

## BILLET ALUMINUM LED DASH INDICATOR WITH SENSOR KIT

Transmission	Horizontal Brushed Kit Part No.	Horizontal Black Kit Part No.	Vertical Brushed Kit Part No.	Vertical Black Kit Part No.
350/400	CIND-1715	XCIND-1715	CIND-1716	XCIND-1716
700-R4/4L60	CIND-1717	XCIND-1717	CIND-1718	XCIND-1718
Ford AOD/4R70W/AODE	CIND-1719	XCIND-1719	CIND-1720	XCIND-1720
Ford C4/C6	CIND-1721	XCIND-1721	CIND-1722	XCIND-1722
Chrysler 727/904/518	CIND-1723	XCIND-1723	CIND-1724	XCIND-1724
4L60E/4L80E (Long Selector Shaft)	CIND-1725	XCIND-1725	CIND-1726	XCIND-1726
200-4R	CIND-1727	XCIND-1727	CIND-1728	XCIND-1728

## BILLET ALUMINUM LED DASH BEZELS ONLY

Transmission	Horizontal Brushed Part No.	Horizontal Black Part No.	Vertical Brushed Part No.	Vertical Black Part No.
350/400/200/C4/C6/727/904/518	CIND-1700	XCIND-1700	CIND-1701	XCIND-1701
700-R4/200-4R/4L60/4L60E/4L80E	CIND-1702	XCIND-1702	CIND-1703	XCIND-1703
Ford AOD/4R70W/AODE	CIND-1704	XCIND-1704	CIND-1705	XCIND-1705



Horizontal Mount (Black)



Vertical Mount (Black)

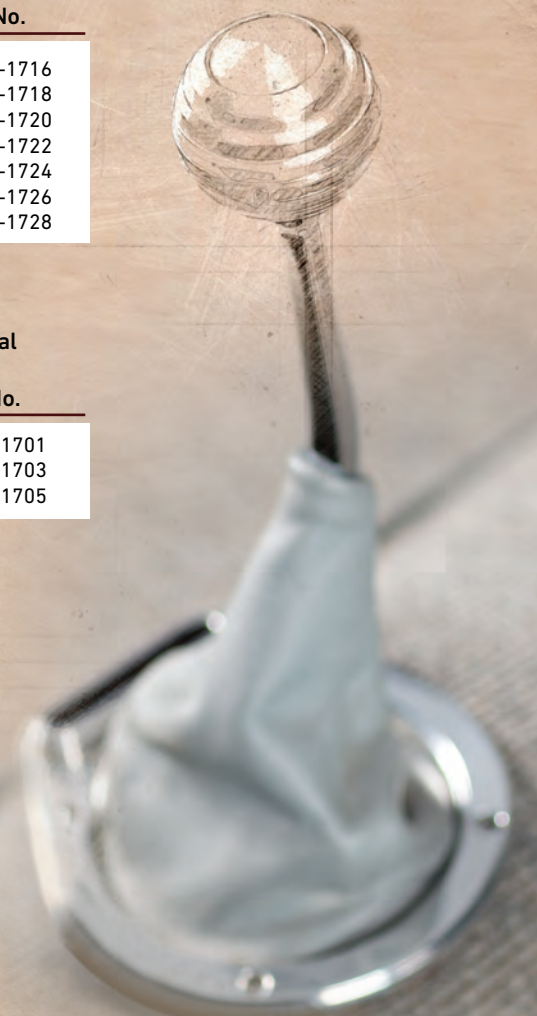



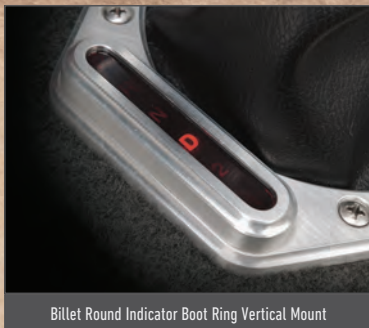

Billet Round Indicator Boot Ring Vertical Mount



Billet Round Indicator Boot Ring Horizontal Mount



Billet Rectangular Indicator Boot Ring Horizontal Mount



Black Billet Rectangular Indicator Boot Ring Horizontal Mount



Black Billet Rectangular Indicator Boot Ring Vertical Mount



Billet Rectangular Indicator Boot Ring Vertical Mount

### BILLET ALUMINUM LED BOOT INDICATOR WITH SENSOR KIT

ROUND STYLE	Horizontal Round Brushed Part No.	Horizontal Round Black Part No.	Vertical Round Brushed Part No.	Vertical Round Black Part No.
Transmission				
350/400	CINB-1747	XCINB-1747	CINB-1748	XCINB-1748
700-R4/4L60	CINB-1749	XCINB-1749	CINB-1750	XCINB-1750
Ford AOD/4R70W/AODE	CINB-1751	XCINB-1751	CINB-1752	XCINB-1752
Ford C4/C6	CINB-1753	XCINB-1753	CINB-1754	XCINB-1754
Chrysler 727/904/518	CINB-1755	XCINB-1755	CINB-1756	XCINB-1756
4L60E/4L80E (Long Selector Shaft)	CINB-1757	XCINB-1757	CINB-1758	XCINB-1758
200-4R	CINB-1759	XCINB-1759	CINB-1760	XCINB-1760

RECTANGULAR STYLE	Horizontal Rectangular Brushed Part No.	Horizontal Rectangular Black Part No.	Vertical Rectangular Brushed Part No.	Vertical Rectangular Black Part No.
Transmission				
350/400	CINB-1779	XCINB-1779	CINB-1780	XCINB-1780
700-R4/4L60	CINB-1781	XCINB-1781	CINB-1782	XCINB-1782
Ford AOD/4R70W/AODE	CINB-1783	XCINB-1783	CINB-1784	XCINB-1784
Ford C4/C6	CINB-1785	XCINB-1785	CINB-1786	XCINB-1786
Chrysler 727/904/518	CINB-1787	XCINB-1787	CINB-1788	XCINB-1788
4L60E/4L80E (Long Selector Shaft)	CINB-1789	XCINB-1789	CINB-1790	XCINB-1790
200-4R	CINB-1791	XCINB-1791	CINB-1792	XCINB-1792

### BILLET ALUMINUM LED BOOT INDICATOR WITH BOOT (W/O SENSOR KIT)

ROUND STYLE	Horizontal Round Brushed Part No.	Horizontal Round Black Part No.	Vertical Round Brushed Part No.	Vertical Round Black Part No.
Transmission				
350/400/200/C4/C6/727/904/518	CINB-1731	XCINB-1731	CINB-1732	XCINB-1732
700-R4/200-4R/4L60/4L60E/4L80E	CINB-1733	XCINB-1733	CINB-1734	XCINB-1734
Ford AOD/4R70W/AODE	CINB-1735	XCINB-1735	CINB-1736	XCINB-1736

RECTANGULAR STYLE	Horizontal Rectangular Brushed Part No.	Horizontal Rectangular Black Part No.	Vertical Rectangular Brushed Part No.	Vertical Rectangular Black Part No.
Transmission				
350/400/200/C4/C6/727/904/518	CINB-1763	XCINB-1763	CINB-1764	XCINB-1764
700-R4/200-4R/4L60/4L60E/4L80E	CINB-1765	XCINB-1765	CINB-1766	XCINB-1766
Ford AOD/4R70W/AODE	CINB-1767	XCINB-1767	CINB-1768	XCINB-1768



## CABLE OPERATED SHIFT SENSOR KITS

Lokar's Cable Operated LED Shift Indicator is designed for the flexibility to mount it in a variety of locations such as under the hood on the transmission, attached to the frame rail, to the floor pan, on the firewall or on the inner fender well.

Remote Mounting Kit available for those out of the way, distant locations inside the vehicle, such as under the dash, behind the seat or in the trunk.

### FEATURES

- Arm and Ball-Milled Sensor Housing CNC machined from 6061-T6 Billet Aluminum
- Programmable Solid State Circuit Board within the decoder box
- Cable operated for flexibility in mounting
- Kit includes 5' of "U-Cut-to-Fit" stainless steel braided housing and 6' of inner control wire
- Back-Up Light circuit built in
- Neutral safety switch built in
- Stainless steel and zinc plated mounting hardware
- Zinc plated Universal Angled Mounting Brackets
- Color-coded wiring instructions for easy installation
- Compatible for use with all Lokar Automatic Transmission Shifters
- Compatible with many other aftermarket shifters
- Available for most GM, Ford and Chrysler Automatic Transmissions
- Sensor Kit available separately
- Remote Kit available with 7' of "U-Cut-to-Fit" stainless steel braided housing and 13' of inner control wire and adjustable fitting (Sold Separately)
- Special lengths available upon request

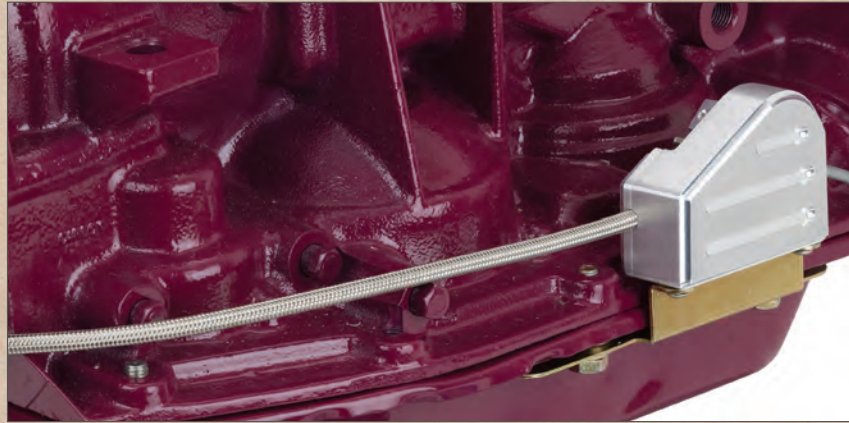

Ford AOD transmission



### SENSOR AND REMOTE KITS

TRANSMISSION	DESCRIPTION	PART NO.
CINS-1797	Cable Operated Sensor Kit 350/400/700-R4/4L60	GM
CINS-17002	Cable Operated Sensor Kit (for Long Selector Shaft) 4L60E/4L80E	GM
CINS-17003	Cable Operated Sensor Kit	GM 200-4R
CINS-1798	Cable Operated Sensor Kit AODE	Ford AOD/4R70W/
CINS-1799	Cable Operated Sensor Kit	Ford C4/C6
CINS-17001	Cable Operated Sensor Kit 727/904/518	Chrysler
CINR-1796	Remote Mounting Cable Kit	All Applications



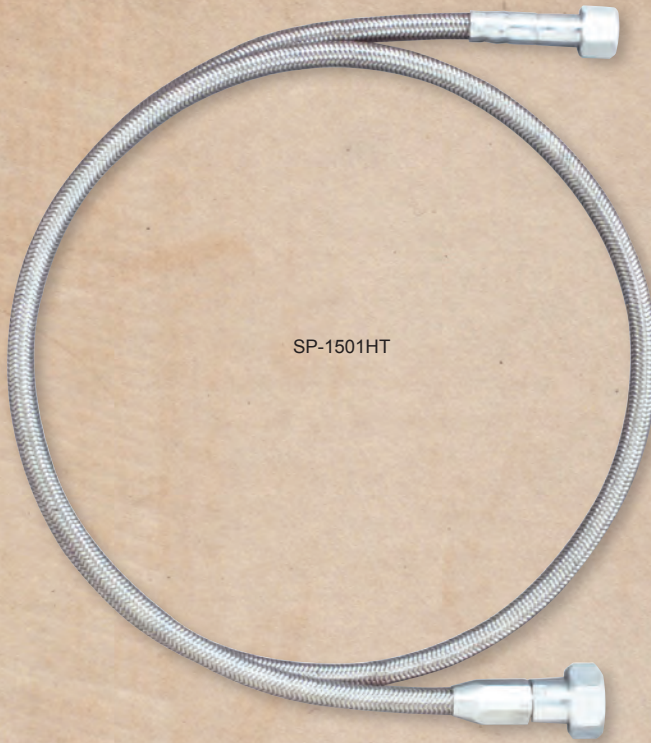

SP-1501HT

### U-CUT-TO-FIT SPEEDOMETER CABLE KITS

Premium housing designed with a specially extruded liner for extended life of the cable and billet aluminum fittings. Inner cable and outer housing are "U-Cut-to-Fit". Kit comes complete with all fittings and is available for GM, Ford and Chrysler applications. (Gauges not included)

Lokar Speedometer Cables are designed to work with most cable driven aftermarket speedometer gauges (such as Auto Meter, Stewart Warner, VDO, Classic Instruments, etc.) or factory speedometer gauges with a 5/8"-18 male thread at the speedo.

Lokar Speedometer Cables are designed to fit into the transmission gear adapter (not supplied in Chevy or Chrysler Lokar Kit). Customer must have the trans end adapter and speedometer gear for all Chevy and Chrysler applications. For Ford applications, the gear adapter is supplied in the Lokar Kit. Customer must supply the speedo gear and speedo gear retainer clip.

All Lokar Speedometer Cables are seven feet (7') long and designed to be "U-Cut-to-Fit". Additional length cable in black or stainless housing is available upon request for an additional charge.

**APPLICATION**

Chevy TH350, TH400, 700-R4, Powerglide, TH200, 200-4R & 4L60 Chrysler 727 & 904

Ford C4, C6, AOD and FMX

Early Ford Speedo with Chevy/Chrysler trans (1948 and earlier original speedo)\*

Early Ford Speedo with Ford trans (1948 and earlier original speedo)\*

**PART NO.**

**DESCRIPTION**

SP-1500U Black Housing Speedo  
SP-1501HT Stainless Housing Speedo

SP-1502U Black Housing Speedo  
SP-1503HT Stainless Housing Speedo

SP-1504U Black Housing Speedo  
SP-1505HT Stainless Housing Speedo

SP-1506U Black Housing Speedo  
SP-1507HT Stainless Housing Speedo



SP-1500U

\*Must have a 3/4"-20 female thread at the speedometer

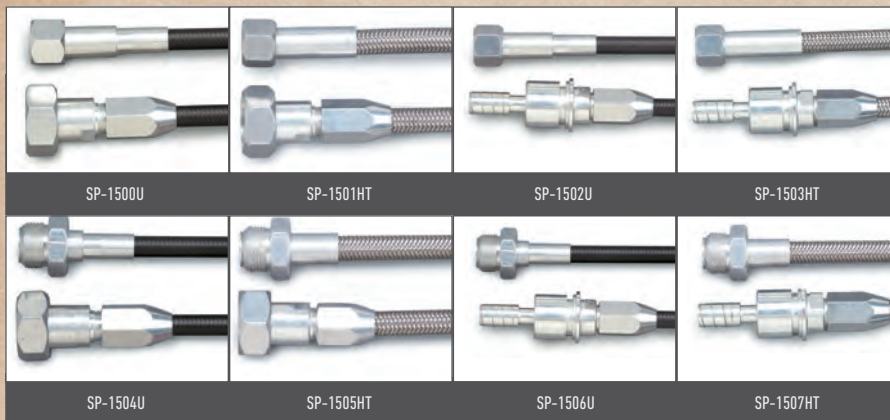

Transmission End Attachment

Speedo End Attachment



# Interior Products

## OVAL BILLET ALUMINUM DASH INSERT FOR 1932 FORD



Oval Billet Aluminum Dash Insert features recessed face design. Designed to fit original 1932 Ford dash. Styles available for VDO, Classic Instruments, Ford Masterpiece and Auto Meter Gauges. Gauges mount from back of insert. Two green 12 volt turn signal LEDs and one red 12 volt high beam LED included. Holding clips and screws included. **Gauges not included.** Available in brushed or polished. Dimensions: 11-13/16" x 4-5/8" x 3/4" depth.



Black Anodized Finish available by special order. Call for details.

### 1932 FORD DASH INSERT DESCRIPTION / GAUGE STYLE

3-1/8" VDO, Auto Meter Street Rod Series, Ford Masterpiece  
3-3/8" Classic Instrument Flat Lens only, Low Step Bezel only  
3-3/8" Classic Instrument Flat Lens only, High Step Bezel only

5 GAUGE  
POLISHED  
PART NO.

BDI-9102

5 GAUGE  
BRUSHED  
PART NO.

BDI-9103

2 GAUGE  
POLISHED  
PART NO.

BDI-9100  
BDI-9128

2 GAUGE  
BRUSHED  
PART NO.

BDI-9101  
BDI-9129

## OVAL BILLET ALUMINUM DASH INSERT 5 GAUGE

Oval Billet Aluminum Dash Insert features recessed face design. Gauges mount from back of insert. Styles available for VDO, Auto Meter, Moon, Stewart Warner, Dolphin, Dakota Digital, Classic Instruments and Ford Motorsports Gauges. Two green 12 volt turn signal LEDs and one red 12 volt high beam LED included. Holding clips and screws included. **Gauges not included.** Available in brushed or polished. Dimensions: 13-15/16" x 4-5/8", 3/4" depth.



## OVAL BILLET ALUMINUM DASH INSERT 6 GAUGE

Oval Billet Aluminum Dash Insert features recessed face design. Gauges mount from back of insert. Styles available for VDO, Auto Meter, Moon, Stewart Warner, Dolphin, Dakota Digital, Classic Instruments, and Ford Motorsports Gauges. Two green 12 volt turn signal LEDs and one red 12 volt high beam LED included. Holding clips and screws included. **Gauges not included.** Available in brushed or polished. Dimensions: 17-3/4" x 4-5/8", 3/4" depth.



### DESCRIPTION / GAUGE STYLE

3-1/8" VDO, Auto Meter Street Rod Series, Ford Masterpiece  
3-3/8" VDO, Dakota Digital (including Stewart Warner Winged Series)  
3-3/8" Stewart Warner (excluding Winged Series)  
3-3/8" Auto Meter Traditional and Moon  
3-3/8" Dolphin  
3-3/8" Classic Instruments Flat Lens only, Low Step Bezel only  
3-3/8" Classic Instrument Flat Lens only, High Step Bezel only

5 GAUGE  
POLISHED  
PART NO.

BDI-9104  
BDI-9108  
BDI-9112  
BDI-9116  
BDI-9120  
BDI-9124  
BDI-9130

5 GAUGE  
BRUSHED  
PART NO.

BDI-9105  
BDI-9109  
BDI-9113  
BDI-9117  
BDI-9121  
BDI-9125  
BDI-9131

6 GAUGE  
POLISHED  
PART NO.

BDI-9106  
BDI-9110  
BDI-9114  
BDI-9118  
BDI-9122  
BDI-9126  
BDI-9132

6 GAUGE  
BRUSHED  
PART NO.

BDI-9107  
BDI-9111  
BDI-9115  
BDI-9119  
BDI-9123  
BDI-9127  
BDI-9133





### GOOLSBY EDITION BY LOKAR BILLET ALUMINUM DASH INSERT

The Goolsby Edition by Lokar Billet Aluminum Dash Insert is available in brushed and polished finishes. Made of sturdy billet aluminum construction. It accepts one 3-3/8" gauge and four 2-1/16" gauges. The through holes accommodate common aftermarket switches. The inserts are available in engine turn, mother of pearl, and tortoise shell. The design complements other products in the Goolsby Edition series.



Goolsby Dash with Engine Turn Insert

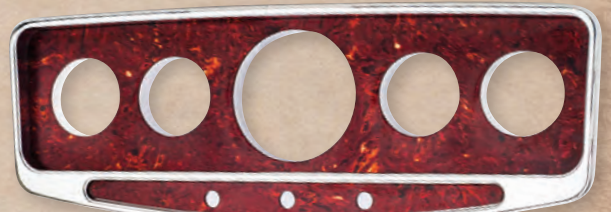

Goolsby Dash with Tortoise Shell Insert

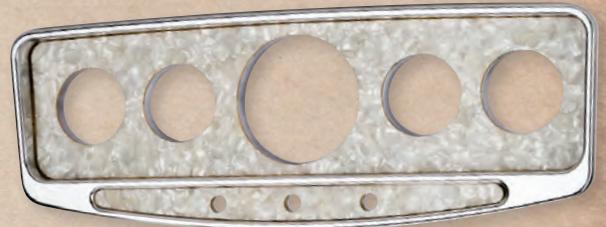

Goolsby Dash with Mother-Of-Pearl Insert

**PART NO.**      **DESCRIPTION**

- BDI-9138 Goolsby By Lokar Dash with Engine Turn Insert
- BDI-9139 Goolsby By Lokar Dash with Mother-Of-Pearl Insert
- BDI-9140 Goolsby By Lokar Dash with Tortoise Shell Insert

### GOOLSBY EDITION BY LOKAR 1932 FORD ROADSTER DOOR SILLS

The Goolsby Edition by Lokar 1932 Ford Roadster Door Sills are available in brushed and polished finishes. Made of sturdy billet aluminum construction. The inserts are available in your choice of engine turn, mother of pearl and tortoise shell. The product is a direct fit for the '32 Ford Roadster. The design complements other products in the Goolsby Edition series.

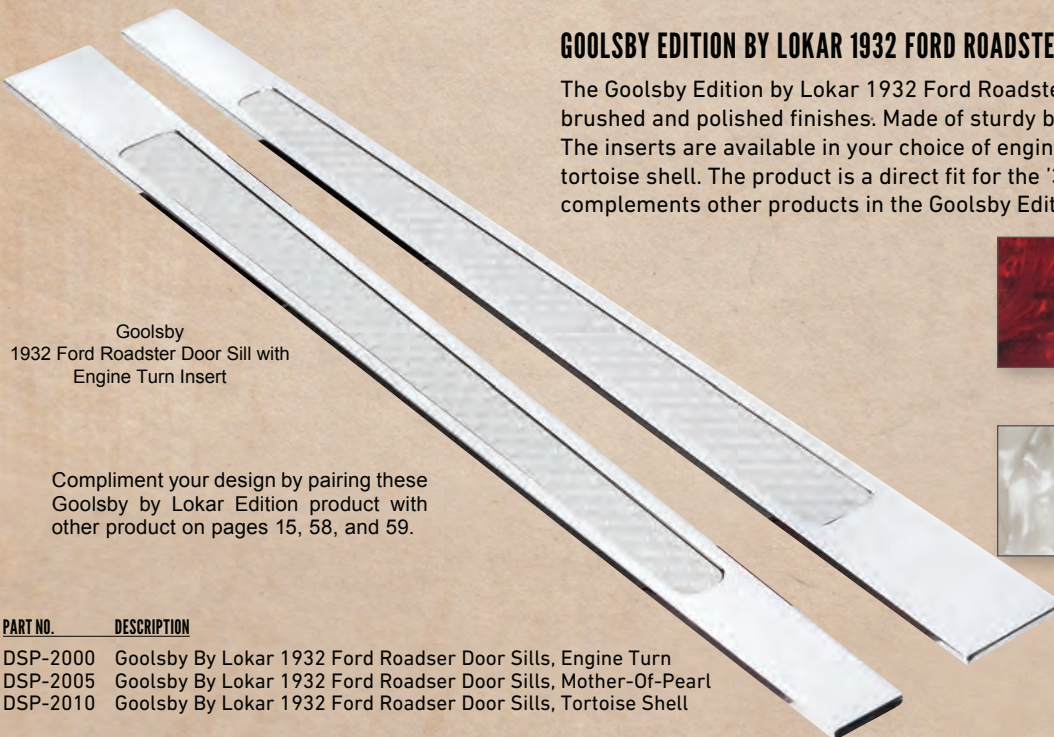

Goolsby 1932 Ford Roadster Door Sill with Engine Turn Insert

Compliment your design by pairing these Goolsby by Lokar Edition product with other product on pages 15, 58, and 59.

**PART NO.**      **DESCRIPTION**

- DSP-2000 Goolsby By Lokar 1932 Ford Roadster Door Sills, Engine Turn
- DSP-2005 Goolsby By Lokar 1932 Ford Roadster Door Sills, Mother-Of-Pearl
- DSP-2010 Goolsby By Lokar 1932 Ford Roadster Door Sills, Tortoise Shell

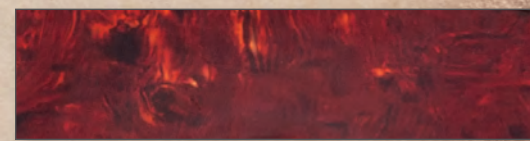

Tortoise Shell Inlay

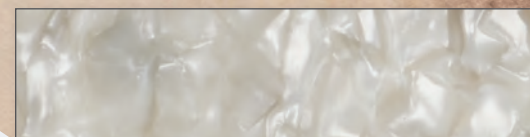

Mother-Of-Pearl Inlay





## BILLET ALUMINUM COLUMN WARE™

3-piece Seamless Steering Column Dress-Up Kit. Unique one-piece solid billet aluminum design. Kit includes Turn Signal Lever, Tilt Steering Lever and Emergency Flasher Knob. Kit fits all GM, 1969 through 1976 Chrysler, and all aftermarket columns with single screw design. Appearance is smooth and sleek and adds class and style to any column.

### PART NO. DESCRIPTION

DUK-2200	Steering Column Dress-Up Kit - Brushed
DUK-2201	Steering Column Dress-Up Kit - Polished
XDUK-2200	Steering Column Dress-up Kit - Black



## GOOLSBY EDGE EDITION INTERIOR DOOR PULLS

Modern Universal Interior door pulls with up to 18 options to match your vehicle's interior.

	STANDARD			XL SIZE		
	BRUSHED	POLISHED	BLACK	BRUSHED	POLISHED	BLACK
SMOOTH INSERT	GSE-2150	GSE-2156	XGSE-2150	GSE-2153	GSE-2159	XGSE-2153
EDGE INSERT	GSE-2151	GSE-2157	XGSE-2151	GSE-2154	GSE-2160	XGSE-2154
UPHOLSTERY READY INSERT	GSE-2152	GSE-2158	XGSE-2152	GSE-2155	GSE-2161	XGSE-2155

### FEATURES

- Standard & XL Size
- Available in Brushed, Polished, & Black
- 3 Insert Options:
  - Solid (Smooth Finish)
  - Edge Edition (Matches Pedal Pads on Page 58)
  - Wrappable (Upholstery Ready)
- Securely Bolts To Door Panel
- Mounting Hardware Included





## OVAL BILLET ALUMINUM INTERIOR DOOR HANDLES

- Recessed mounting design
- Complete with mounting back plate and hardware
- Rubber trigger stop provides quiet return of lever
- Available in brushed, polished, or black finish

PART NO.	DESCRIPTION
IDH-2000	Oval Billet Aluminum Interior Door Handles (Pair) - Brushed
IDH-2001	Oval Billet Aluminum Interior Door Handles (Pair) - Polished
XIDH-2000	Oval Billet Aluminum Interior Door Handles (Pair) - Black



Polished

Brushed

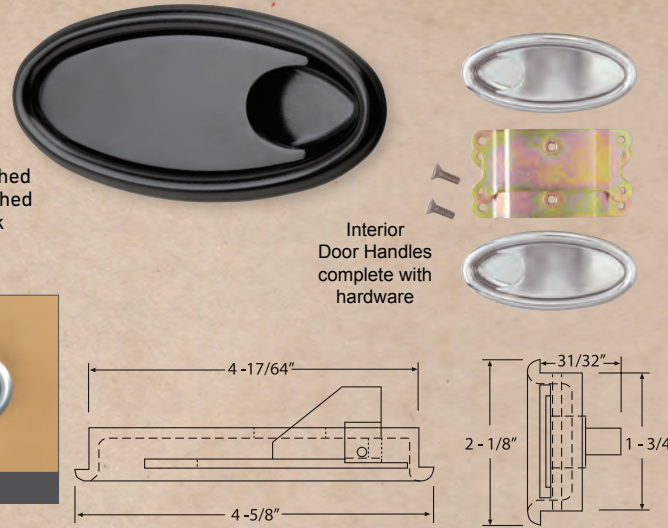

Interior Door Handles complete with hardware

## UNIVERSAL DOOR LATCH CABLE RELEASE KIT

- Shielded pulley for a more direct pulling angle
- "U-Cut-to-Fit" stainless steel cable wire 36"
- Adjustable cable connection
- Eliminates solid rods and bell cranks
- Compatible with bear claw style latches

PART NO.	DESCRIPTION
DLR-2100	Universal Door Latch Cable Release Kit (Pair)
S-2105	Spare / Replacement Pulley (Pair)

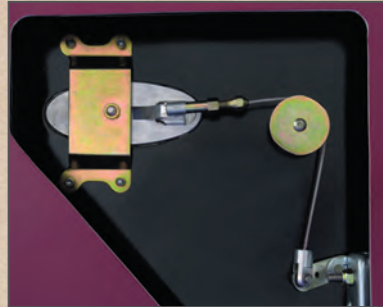
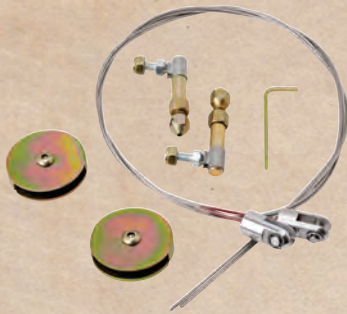

Spare / Replacement 1-1/2" Shielded Pulley Assembly (Sold in Pairs) Part # S-2105

## BILLET ALUMINUM ARM REST DOOR PULLS

- Two screw installation, Stainless Screws included
- Deep pocket - 4 finger width
- Designed to recess in arm rest
- Mounting bracket included
- Sold in pairs
- Complements Lokar Door Handles, Pedals and Dash Inserts
- Available in brushed, polished or black finish

PART NO.	DESCRIPTION
IDP-2004	Oval Arm Rest Door Pull - Brushed
IDP-2005	Oval Arm Rest Door Pull - Polished
XIDP-2004	Oval Arm Rest Door Pull - Black
IDP-2002	Crescent Oval Arm Rest Door Pull - Brushed
IDP-2003	Crescent Oval Arm Rest Door Pull - Polished
XIDP-2002	Crescent Oval Arm Rest Door Pull - Black



Brushed Oval Billet Arm Rest Door Pull

Polished Oval Billet Arm Rest Door Pull

Black Oval Arm Rest Door Pull

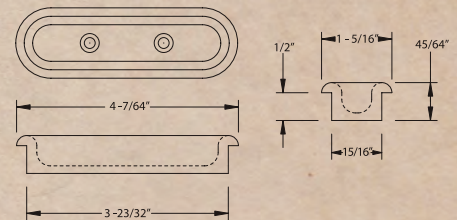

Oval Arm Rest Door Pull



Brushed Crescent Oval Billet Arm Rest Door Pull

Polished Crescent Oval Billet Arm Rest Door Pull

Black Crescent Oval Arm Rest Door Pull

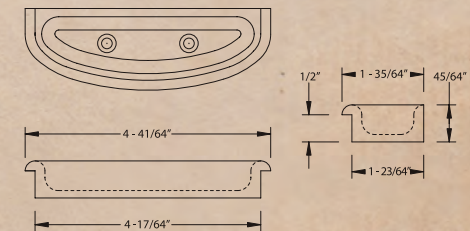

Crescent Oval Arm Rest Door Pull



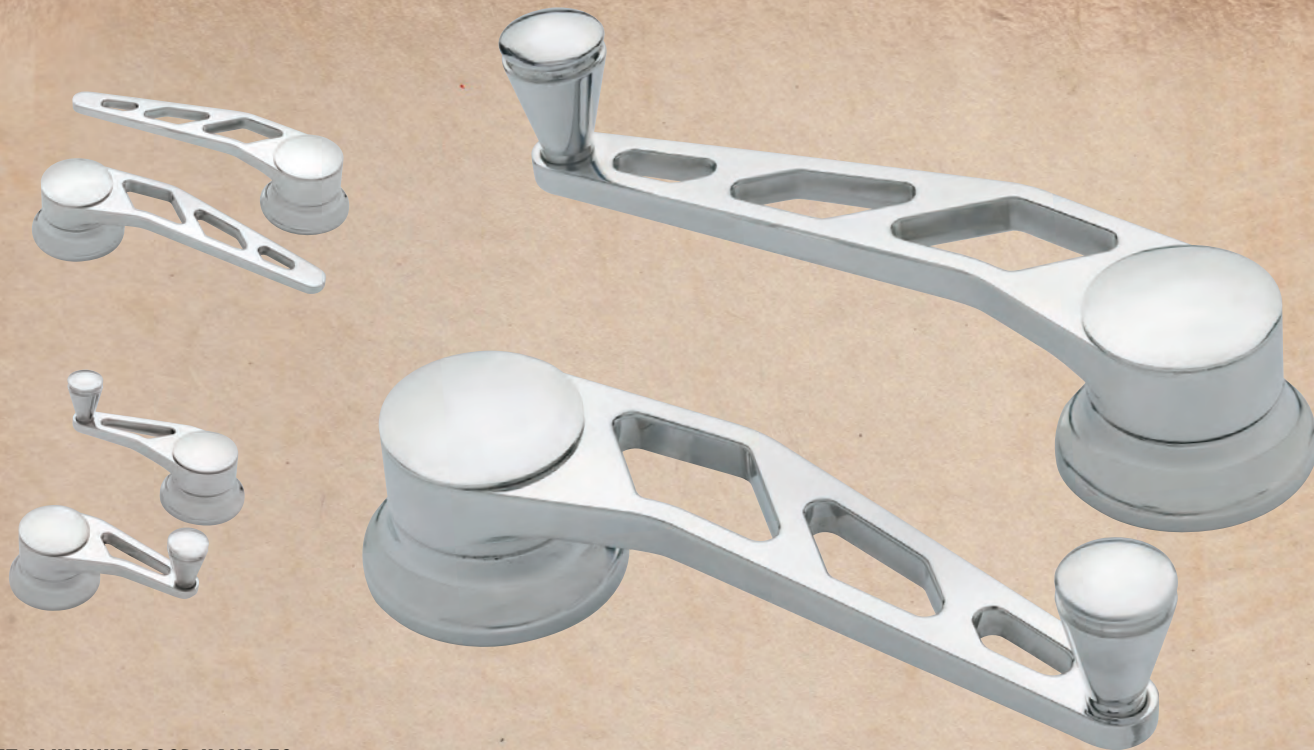

## BILLET ALUMINUM DOOR HANDLES, WINDOW CRANKS & VENT WINDOW CRANKS

- Splined Arms for fine adjustment
- Available for most GM and Ford Applications
- Windowed Arms match other quality Lokar products
- Hidden set screws
- Available in brushed, polished, or black finish

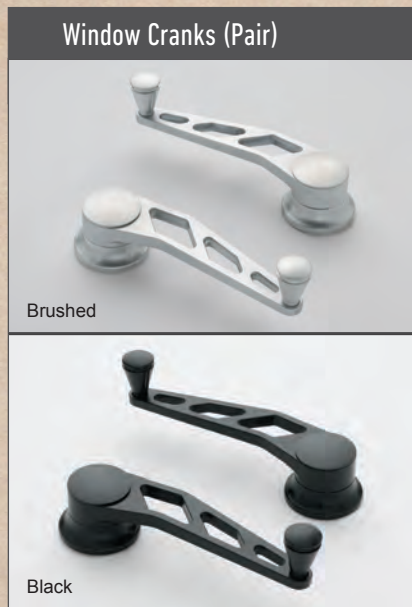

Door Handles (Pair)			Window Cranks (Pair)			Vent Window Cranks (Pair)		
PART NO.	DESCRIPTION	FINISH	PART NO.	DESCRIPTION	FINISH	PART NO.	DESCRIPTION	FINISH
IDH-2006	GM Pre-1949	Brushed	IDH-2012	GM Pre-1949	Brushed	IDH-2018	GM Pre-1949	Brushed
IDH-2007	GM Pre-1949	Polished	IDH-2013	GM Pre-1949	Polished	IDH-2019	GM Pre-1949	Polished
XIDH-2006	GM Pre-1949	Black	XIDH-2012	GM Pre-1949	Black	XIDH-2018	GM Pre-1949	Black
IDH-2008	GM & Ford 1949 & Later	Brushed	IDH-2014	GM & Ford 1949 & Later	Brushed	IDH-2020	GM & Ford 1949 & Later	Brushed
IDH-2009	GM & Ford 1949 & Later	Polished	IDH-2015	GM & Ford 1949 & Later	Polished	IDH-2021	GM & Ford 1949 & Later	Polished
XIDH-2008	GM & Ford 1949 & Later	Black	XIDH-2014	GM & Ford 1949 & Later	Black	XIDH-2020	GM & Ford 1949 & Later	Black
IDH-2010	Ford Pre-1949	Brushed	IDH-2016	Ford Pre-1949	Brushed	IDH-2022	Ford Pre-1949	Brushed
IDH-2011	Ford Pre-1949	Polished	IDH-2017	Ford Pre-1949	Polished	IDH-2023	Ford Pre-1949	Polished
XIDH-2010	Ford Pre-1949	Black	XIDH-2016	Ford Pre-1949	Black	XIDH-2022	Ford Pre-1949	Black





**LAKESTER DOOR HANDLES,  
WINDOW CRANKS & VENT WINDOW CRANKS**

- Nostalgia Styling
- Splined Arms for full 360 degree fine adjustment
- Hidden set screws
- Available in chrome, black and raw finish
- Matches Lakester Throttle Pedal and Brake Pedal sets (page 56)
- Available for most GM and Ford applications



**Door Handles (Pair)**



Chrome



Raw

**Window Cranks (Pair)**



Chrome

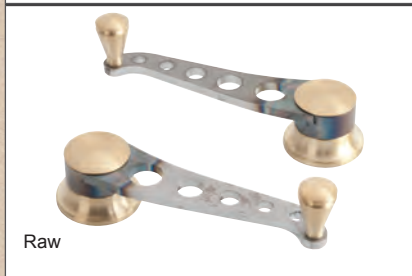

Raw

**Vent Window Cranks (Pair)**



Chrome



Raw

Door Handles (Pair)		
PART NO.	DESCRIPTION	FINISH
IDH-2024	GM Pre-1949	Chrome
IDH-2027	GM Pre-1949	Raw
XIDH-2024	GM Pre-1949	Black
IDH-2025	GM & Ford 1949 & Later	Chrome
IDH-2028	GM & Ford 1949 & Later	Raw
XIDH-2025	GM & Ford 1949 & Later	Black
IDH-2026	Ford Pre-1949	Chrome
IDH-2029	Ford Pre-1949	Raw
XIDH-2026	Ford Pre-1949	Black

Window Cranks (Pair)		
PART NO.	DESCRIPTION	FINISH
IDH-2030	GM Pre-1949	Chrome
IDH-2033	GM Pre-1949	Raw
XIDH-2030	GM Pre-1949	Black
IDH-2031	GM & Ford 1949 & Later	Chrome
IDH-2034	GM & Ford 1949 & Later	Raw
XIDH-2031	GM & Ford 1949 & Later	Black
IDH-2032	Ford Pre-1949	Chrome
IDH-2035	Ford Pre-1949	Raw
XIDH-2032	Ford Pre-1949	Black

Vent Window Cranks (Pair)		
PART NO.	DESCRIPTION	FINISH
IDH-2036	GM Pre-1949	Chrome
IDH-2039	GM Pre-1949	Raw
XIDH-2036	GM Pre-1949	Black
IDH-2037	GM & Ford 1949 & Later	Chrome
IDH-2040	GM & Ford 1949 & Later	Raw
XIDH-2037	GM & Ford 1949 & Later	Black
IDH-2038	Ford Pre-1949	Chrome
IDH-2041	Ford Pre-1949	Raw
XIDH-2038	Ford Pre-1949	Black



## COMBINATION HOOD & TRUNK RELEASE CABLE KITS

Billet aluminum handle assembly for both the hood and trunk. The cables are "U-Cut-to-Fit", designed with specially extruded liner for extended life of the cable, with aluminum fittings and stainless steel inner wire. Hood release includes aluminum firewall fittings and cable stop. Outer housing is 18 inches inside the vehicle and 6 feet under the hood. Inner wire is 9 feet long. Trunk release includes cable stop. The outer housing is 15 feet long and the inner wire is 16 feet long. Requires cable-operated latches.

PART NO.	DESCRIPTION
CHT-1300HT	Combination Hood & Trunk Release Cable Kit – Stainless Housing - Brushed
XCHT-1300HT	Combination Hood & Trunk Release Cable Kit – Stainless Housing - Black
CHT-1300U	Combination Hood & Trunk Release Cable Kit – Black Housing - Brushed
XCHT-1300U	Combination Hood & Trunk Release Cable Kit – Black Housing - Black

Right hand kits available upon request.

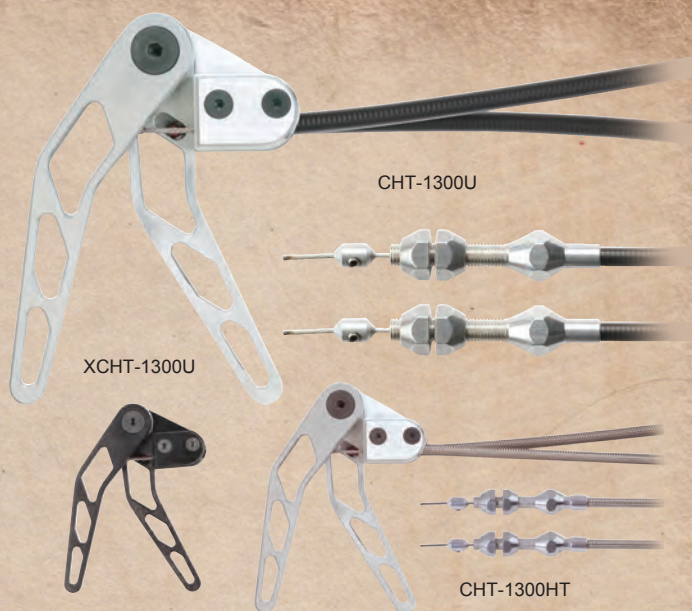

## TRUNK RELEASE CABLE KITS

Trunk release kit includes cable stop, 15 feet of outer housing and 16 feet of inner wire. Requires cable-operated latches.

PART NO.	DESCRIPTION
TR-1200HT	Trunk Release Cable Kit – Stainless Housing - Brushed
XTR-1200HT	Trunk Release Cable Kit – Stainless Housing - Black
TR-1200U	Trunk Release Cable Kit – Black Housing - Brushed
XTR-1200U	Trunk Release Cable Kit – Black Housing - Black

Right hand kits available upon request.

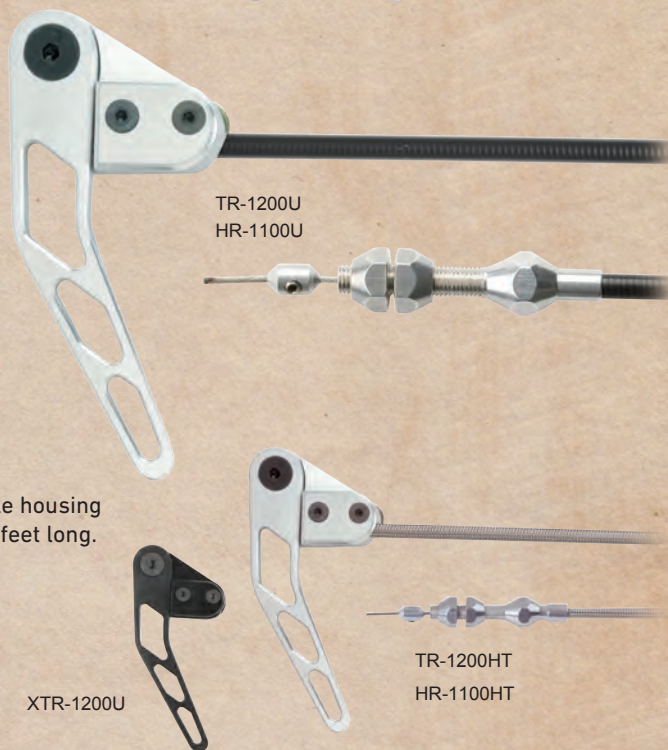

## HOOD RELEASE CABLE KITS

Hood release kit includes aluminum firewall fittings and cable stop. The cable housing is 24 inches inside the vehicle and 6 feet under the hood. The inner wire is 9 feet long. Requires cable-operated latches.

PART NO.	DESCRIPTION
HR-1100HT	Hood Release Cable Kit – Stainless Housing - Brushed
XHR-1100HT	Hood Release Cable Kit – Stainless Housing - Black
HR-1100U	Hood Release Cable Kit – Black Housing - Brushed
XHR-1100U	Hood Release Cable Kit – Black Housing - Black

Right hand kits available upon request.

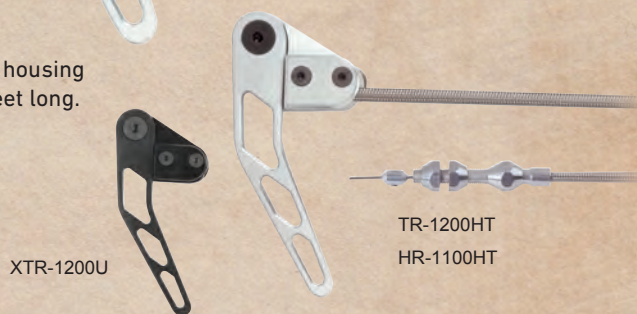

## ADJUSTABLE-LEVEL SELF-LOCKING HOOD AND TRUNK PROP

Constructed of high quality billet aluminum and stainless steel, this Adjustable-Level Hood and Trunk Prop will offer great looks, as well as functionality to your ride. When the hood or trunk is raised, the Hood and Trunk Prop will automatically lock itself into position. This eliminates the need for two hands when opening your hood or trunk. A quick release allows the hood to be opened to its max for easy engine access. We offer two versions of the Hood and Trunk Prop, a three level and six level. This will allow the hood or trunk to be set at various levels without any unsightly objects holding it up. Each level of the six-level prop increases the opening of the hood or trunk by approximately 6 inches. Each level of the three-level prop increases the opening of the hood or trunk by approximately 12 inches.

PART NO.	DESCRIPTION
0401014	Adjustable 3 level Hood and Trunk Prop - Polished
0401024	Adjustable 6 level Hood and Trunk Prop - Polished
X0401014	Adjustable 3 Level Hood and Trunk Prop - Black
X0401024	Adjustable 6 Level Hood and Trunk Prop - Black

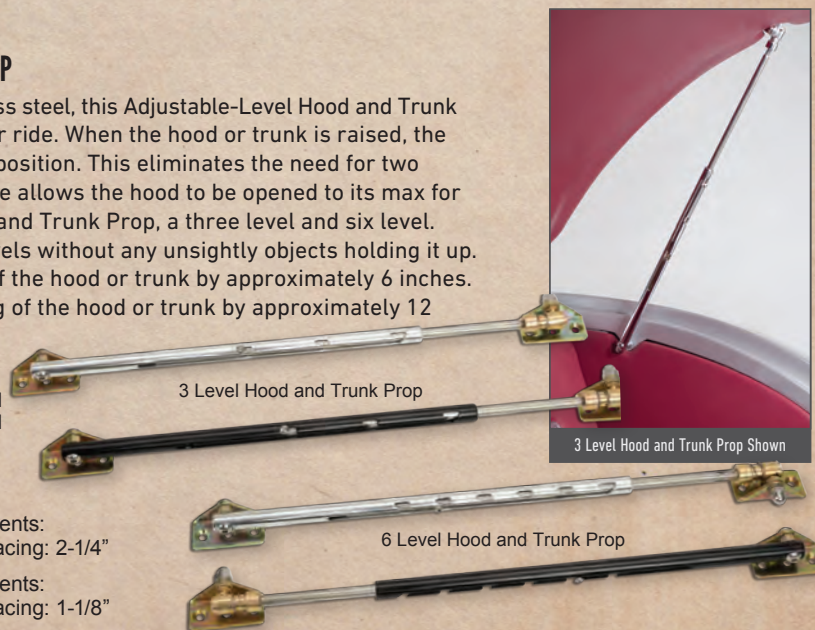

3 position Hood and Trunk Prop Measurements:  
Collapsed: 12" Extended: 19-3/4" Level Spacing: 2-1/4"

6 position Hood and Trunk Prop Measurements:  
Collapsed: 12" Extended: 19-3/4" Level Spacing: 1-1/8"



# Emergency Brakes & Cables

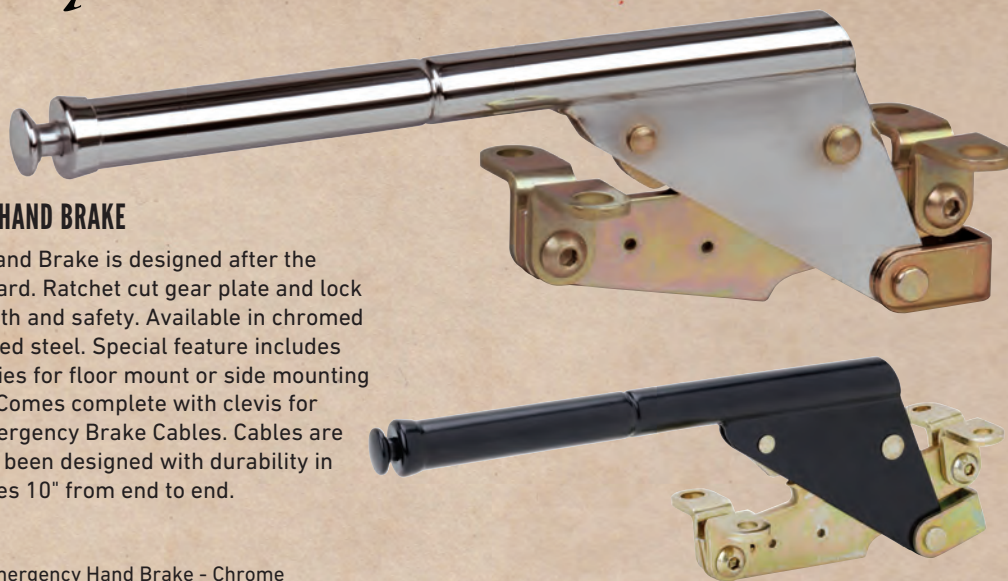

## FLOOR MOUNT EMERGENCY HAND BRAKE

Floor Mount Emergency Hand Brake is designed after the automotive industry standard. Ratchet cut gear plate and lock are heat treated for strength and safety. Available in chromed steel or black powder coated steel. Special feature includes 4-point mounting capabilities for floor mount or side mounting for personal applications. Comes complete with clevis for installation with Lokar Emergency Brake Cables. Cables are sold separately. Lever has been designed with durability in mind. Hand Brake measures 10" from end to end.

PART NO.	DESCRIPTION
EHB-7000F	Floor Mount Emergency Hand Brake - Chrome
XEHB-7000F	Floor Mount Emergency Hand Brake - Black

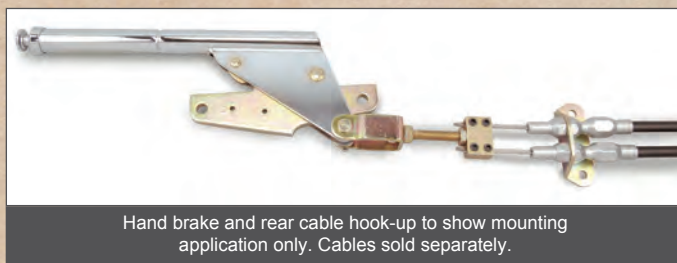

Hand brake and rear cable hook-up to show mounting application only. Cables sold separately.



Ever think about mounting the floor mount hand brake sideways in front of your seat? You can!



Use Lokar Universal Emergency Brake cables. See Page 32.

## EMERGENCY BRAKE WARNING INDICATOR SWITCH KIT

The Emergency Brake Warning Switch Kit operates your dash light or buzzer to alert you when your emergency brake is engaged. Designed for use with the Lokar Floor Mount Hand Brake, Part No. EHB-7000F and XEHB-7000F. Switch mounts to existing holes in gear plate on Floor Mount Hand Brake.

PART NO.	DESCRIPTION
EHB-7001	Emergency Brake Warning Indicator Switch Kit

### KIT INCLUDES:

- Micro Switch
- Warning indicator trigger
- Two electrical terminals
- E-clip and pin
- Two stainless mounting bolts
- Two Nylock nuts

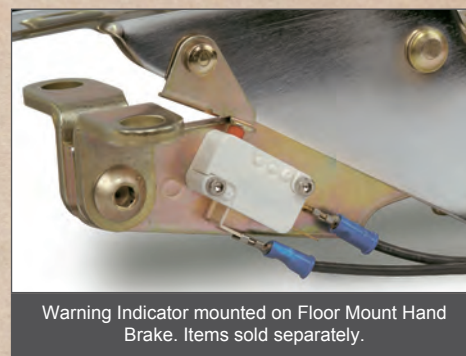

Warning Indicator mounted on Floor Mount Hand Brake. Items sold separately.

## HAND BRAKE BOOT SETS



Lokar Hand Brake Boots are made of black Naugahyde. All sets include a boot, stainless base ring, or billet aluminum ring. Stainless boot rings are available in polished stainless or black powder coat. Aluminum boot rings are available in brushed aluminum or black anodized finish.

DESCRIPTION	STAINLESS RING	BILLET RING	BLACK ANODIZED ALUMINUM RING	BLACK STAINLESS RING
Transmount Emergency Hand Brake Boot	70-EHBT	70-BHBT	X70-BHBT	X70-EHBT
Floor Mount Emergency Hand Brake Boot	70-EHBF	70-BHBF	X70-BHBF	X70-EHBF
Emergency Hand Brake Boot Ring	70-SHR	70-BHR	X70-BHR	X70-SHR



Handbrake Ring Inner Dimensions: 1.5" x 5.25"  
 Stainless Ring Outer Dimensions: 2.5" x 6.25"  
 Aluminum Ring Outer Dimensions: 2.75" x 6.5"





## UNDER-THE-DASH HAND OPERATED EMERGENCY BRAKE

Lokar's Under-the-Dash Hand Operated Emergency Brake gives you ease of operation along with a clean, out of the way emergency brake. There are no cables entering through the firewall. It fits in a space as small as 11" from the firewall to dash. Ratchet cut gear plate and lock are heat treated for strength and safety. The lever has been designed with durability in mind. The pistol grip and trigger allow for comfortable lever operation.

### Features

- Adjustable from 11" to 15" firewall to dash
- Length of the arm measures 13" from the pivot point to the bottom of the grip
- Various location mounting capability
- Simple installation with universal mounting system
- Pistol grip with trigger release
- No welding necessary
- Complete with instructions and all hardware
- Gold iridited brackets
- Connector Cables sold separately
- Available in brushed, chrome or black finish



Use EC-8001U or EC-8001HT Connector Cable.

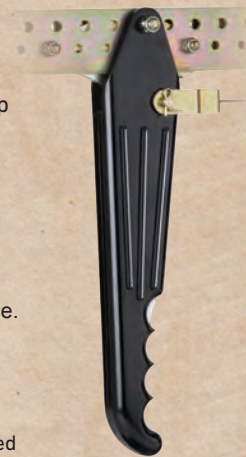

XEHB-9200

### PART NO. DESCRIPTION

EHB-9200	Billet Aluminum Under-the-Dash Hand Operated Emergency Brake - Brushed
XEHB-9200	Billet Aluminum Under-the-Dash Hand Operated Emergency Brake - Black
EHB-9201	Billet Aluminum Under-the-Dash Hand Operated Emergency Brake - Chrome

## TRANSMOUNT EMERGENCY HAND BRAKE

Transmount Emergency Hand Brake is designed after the automotive industry standard. Ratchet cut gear plate and lock are heat treated for strength and safety. The geometrical design of the lever allows for comfortable lever operation. Levers are available in chromed steel or black powder coated steel and come in 11" and 16" lengths to complement Lokar's Automatic Transmission Shifter. Mounting hardware for use with Lokar Automatic Transmission Shifter is included with Transmount Cable Kits and is used with the built-in mounting bracketry included with the shifter kits.

### PART NO. DESCRIPTION

EHB-7011	11" Transmount Emergency Hand Brake - Chrome
XEHB-7011	11" Transmount Emergency Hand Brake - Black
EHB-7016	16" Transmount Emergency Hand Brake - Chrome
XEHB-7016	16" Transmount Emergency Hand Brake - Black



Use 11" hand brake with 16" and shorter shifters; use 16" hand brake with 23" and taller shifters. Use Transmount Emergency Brake Cables.



11" Transmount Hand Brake



Black 16" Transmount Hand Brake

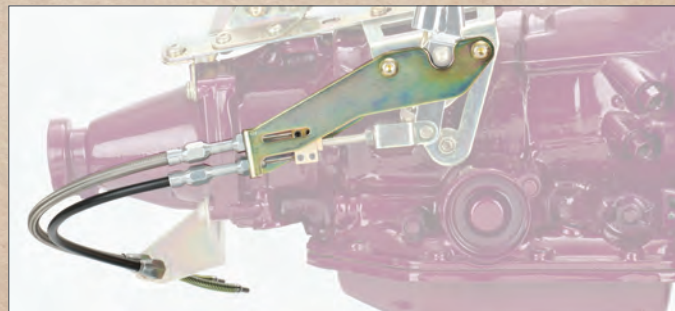

Transmount Hand Brake and rear cable hook-up to show mounting application only. Cables sold separately.



## Award Winning

### UNDER-THE-DASH FOOT OPERATED EMERGENCY BRAKE

Lokar Under-the-Dash Foot Operated Emergency Brake features the same superior craftsmanship you have come to expect of all our products. This foot brake gives you ease of operation along with a clean, out of the way emergency brake.

#### FEATURES

- Adjustable 9" to 13" firewall to dash
- Length of the arm measures 10" from the pivot point to the bottom of the foot pad.
- Various location mounting capability
- Heat treated gears
- Hidden gears and mechanisms for clean finish
- Rubber stop for quiet pedal return
- Applications for finished and unfinished cars
- Complete with instructions and all hardware
- Connector Cables sold separately (See page 34)
- Available in brushed, chrome or black finish



"U-Cut-to-Fit" Release Rod L-Brackets for dash to firewall adjustments

Emergency Brakes & Cables



ORDERING TIP

The windowed arm & foot pads coordinate with the Lokar Pedals, Door Handles, and Window Cranks.



Use EC-8001U or EC-8001HT Connector Cables.



EFB-9003

#### PART NO. DESCRIPTION

EFB-9000	Billet Aluminum Foot Brake with solid arm and ball-milled pad – Brushed
XEFB-9000	Billet Aluminum Foot Brake with solid arm and ball-milled pad – Black
EFB-9001	Billet Aluminum Foot Brake with solid arm and rubber insert in pad – Brushed
XEFB-9001	Billet Aluminum Foot Brake with solid arm and rubber insert in pad – Black
EFB-9002	Billet Aluminum Foot Brake with windowed arm and ball-milled pad – Brushed
EFB-9003	Billet Aluminum Foot Brake with windowed arm and rubber insert in pad – Brushed
XEFB-9003	Billet Aluminum Foot Brake with windowed arm and rubber insert in pad – Black
EFB-9004	Billet Aluminum Foot Brake with solid arm and ball-milled pad – Chrome
EFB-9005	Billet Aluminum Foot Brake with solid arm and rubber insert in pad – Chrome
EFB-9006	Billet Aluminum Foot Brake with windowed arm and ball-milled pad – Chrome
EFB-9007	Billet Aluminum Foot Brake with windowed arm and rubber insert in pad – Chrome
EFB-9008	Billet Aluminum Foot Brake with solid arm and Oval pad with rubber – Brushed
XEFB-9008	Billet Aluminum Foot Brake with solid arm and Oval pad with rubber – Black
EFB-9009	Billet Aluminum Foot Brake with windowed arm and Oval pad with rubber – Brushed
XEFB-9009	Billet Aluminum Foot Brake with windowed arm and Oval pad with rubber – Black
EFB-9010	Billet Aluminum Foot Brake with windowed arm and Oval pad with rubber – Chrome
EFB-9011	Billet Aluminum Foot Brake with solid arm and Oval pad with rubber – Chrome

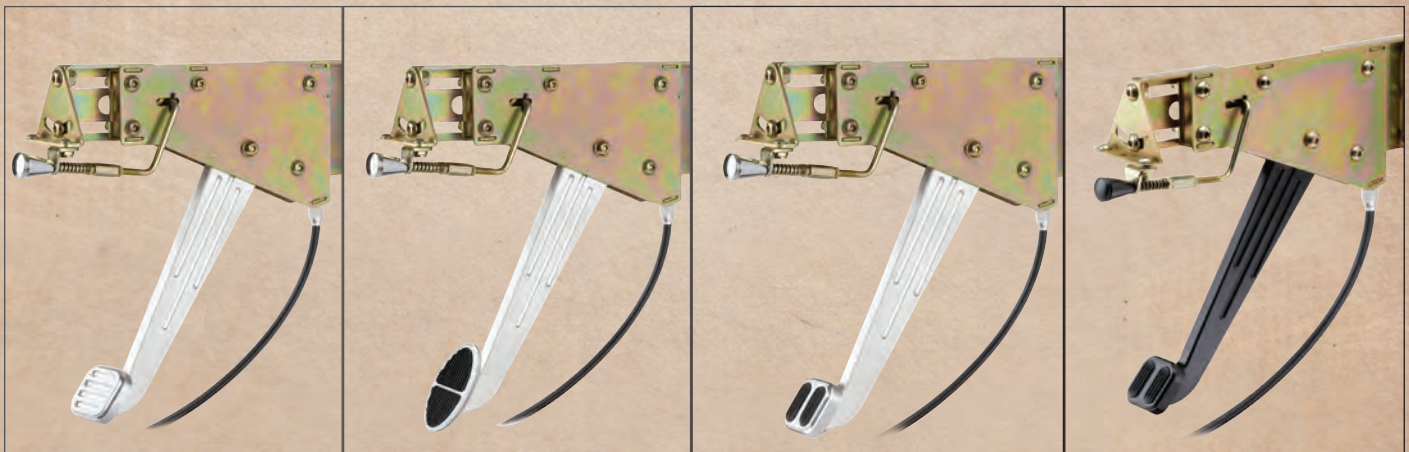
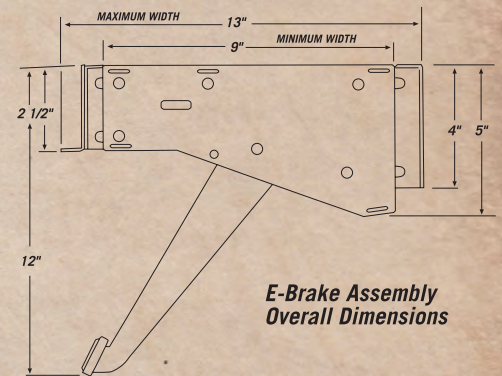

EFB-9000

EFB-9008

EFB-9001

XEFB-9001



## UNIVERSAL EMERGENCY BRAKE CABLES

Kit is designed for use with Lokar's Floor Mount Emergency Hand Brake and in conjunction with Lokar's Connector Cables. Kit comes equipped with quality one-piece aluminum adjusters and aluminum ferrule to eliminate fraying of stainless housing. Outer housing is designed with specially extruded liner for extended life of the cable. Stainless inner cable resists moisture. Design allows rear end backing plate fittings to be removed without removing brake cables. Lokar cables also feature adjustable cable lock and clevis. Kit is complete with cable bracket and spacers. Kit includes two 8 foot outer housings that "U-Cut-to-Fit" and are available in stainless or black housing. Applications: 8" and 9" Ford, Chevy, Chrysler and Lincoln Versailles drum and disc brakes. See chart for additional brake applications. Call for other applications or custom configurations.

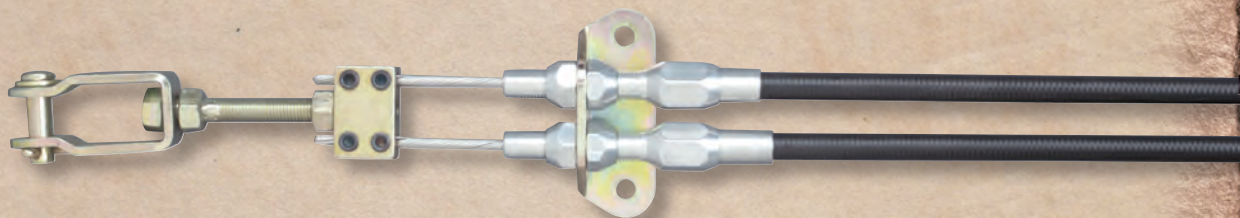
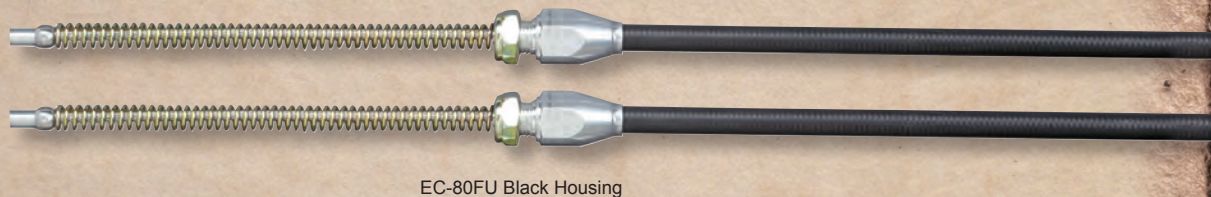
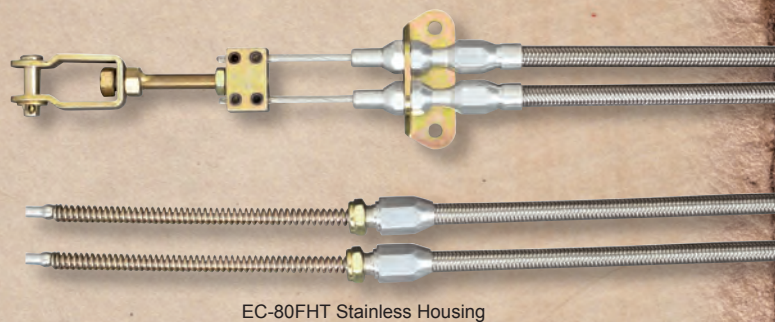

PART NO.	DESCRIPTION
----------	-------------

- |            |  |
|------------|--|
| EC-80FU    | Universal Emergency Brake Cables - Black Housing   |
| EC-80FHT   | Universal Emergency Brake Cables - Stainless Housing   |
| EC-80JAGU  | Jag Rear Brake Cables - Black Housing (specify year and model)                                   |
| EC-80JAGHT | Jag Rear Brake Cables - Stainless Housing (specify year and model)                               |
| EC-80FUTB  | T-Bird Brake Cables - Black Housing  |
| EC-80FHTTB | T-Bird Brake Cables - Stainless Housing  |
| EC-80WU    | Wilwood MC-4 Brake Cables - Black Housing  |
| EC-80WHT   | Wilwood MC-4 Brake Cables - Stainless Housing  |
| EC-81FU    | Ford Explorer/Wilwood Explorer Style Rear Disc Cable Kit - Black Housing (clevises included)     |
| EC-81FHT   | Ford Explorer/Wilwood Explorer Style Rear Disc Cable Kit - Stainless Housing (clevises included) |



Always use anti-seize on aluminum fittings to avoid galling.

Emergency Brake Application	EC-80FU	EC-80JAGU	EC-81FU	EC-80CC	EC-80FUTB	EC-80WC
	EC-80FHT	EC-80JAGHT	EC-81FHT		EC-80FHTTB	
Chevy Drum	•					
Ford Drum	•					
Chrysler Drum	•					
Dana Drum	•					
Lincoln Versailles	•					
1988 & Later Corvette	•					•
Late Model T-Bird '87 to '88					•	
Ford Explorer & Motorsports Disc w/Internal Drum E-Brake			•			
Jag Rear-End		•				
Jag Rear-End w/Wilwood Brakes	•					•
Wilwood Disc w/Internal Drum E-Brake			•			
Corvette '84 to '87	•			•		
Wilwood Disc Stand Alone E-Brake Caliper	•					•
Baer Brakes	•			•		
SSBC Standard Calipers					•	
SSBC w/Integrated E-Brake	•					•
SSBC w/Stand Alone E-Brake Caliper	•					•



## TRANSMOUNT EMERGENCY BRAKE CABLES

Transmount Cable Kit is designed for use with Lokar's Transmount Emergency Hand Brake and includes bracket for mounting cables to hand brake. Kit comes equipped with quality one-piece aluminum adjusters and aluminum ferrule to eliminate fraying of stainless housing. Outer housing is designed with specially extruded liner for extended life of the cable. Stainless steel inner cable resists moisture. Design allows rear end backing plate fittings to be removed without removing brake cables. Lokar cables also feature adjustable cable lock and clevis. Kit includes two 8 foot outer housings that "U-Cut-to-Fit" and are available in stainless housing or black housing. Application fits 8" and 9" Fords, Chevy, Chrysler and Lincoln Versailles drum and disc brakes. See chart on page 32 for additional brake applications.

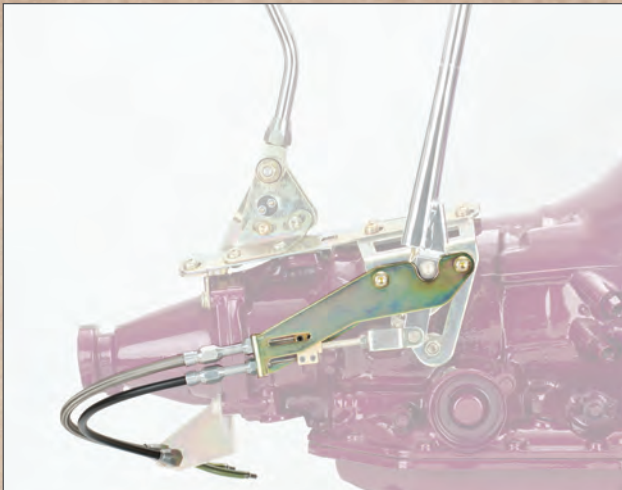

Application illustration only. Cables, Hand Brake and Shifter sold separately.

PART NO.	DESCRIPTION
EC-80TU	Transmount Brake Cables - Black Housing
EC-80THT	Transmount Brake Cables - Stainless Housing
EC-80TUTB	Transmount T-Bird Brake Cables - Black Housing
EC-80THTTB	Transmount T-Bird Brake Cables - Stainless Housing
EC-81TU	Ford Explorer Transmount - Black Housing
EC-81THT	Ford Explorer Transmount - Stainless Housing



For use with Lokar Transmount Emergency Hand Brake only.  
Mounts to Lokar ATS Shifter Brackets.



**INSTALL TIP**  
Always use anti-seize on aluminum fittings to avoid galling.

## U-CUT-TO-FIT REAR BRAKE CABLE KIT FOR 1942 TO 1954 CHEVY TRUCKS

Brake Cable Kits for 1942 to 1954 Chevy Trucks. Cables mount from backing plates on rear end to original cross shaft on chassis. Designed with specially extruded liner for extended life of the cable. Stainless inner cable resists moisture. Kit includes two 4 foot outer housings that "U-Cut-to-Fit" and are available in stainless housing or black housing. Design allows rear end backing plate fittings to be removed without removing brake cables. Lokar cables also feature two adjustable cable locks and clevis. Applications: 8" and 9" Ford, Chevy, Chrysler, and Lincoln Versailles drum and disc brakes. Also fits 1987 and earlier Corvette rears. For 1988 or later Corvette and Wilwood disc brakes (with separate e-brake caliper), cables require a Wilwood Clevis Kit (sold separately).



Under-the-Dash Hand Brake Connector Cable

PART NO.	DESCRIPTION
EC-8004U	'42 to '54 Chevy Truck Brake Cable Kit - Black Housing
EC-8004HT	'42 to '54 Chevy Truck Brake Cable Kit - Stainless Housing
EC-8007U	'42 to '54 Chevy Truck With Ford Explorer or Wilwood Discs w/Internal Drum Brake - Black Housing
EC-8007HT	'42 to '54 Chevy Truck with Ford Explorer or Wilwood Discs w/Internal Drum Brake - Stainless

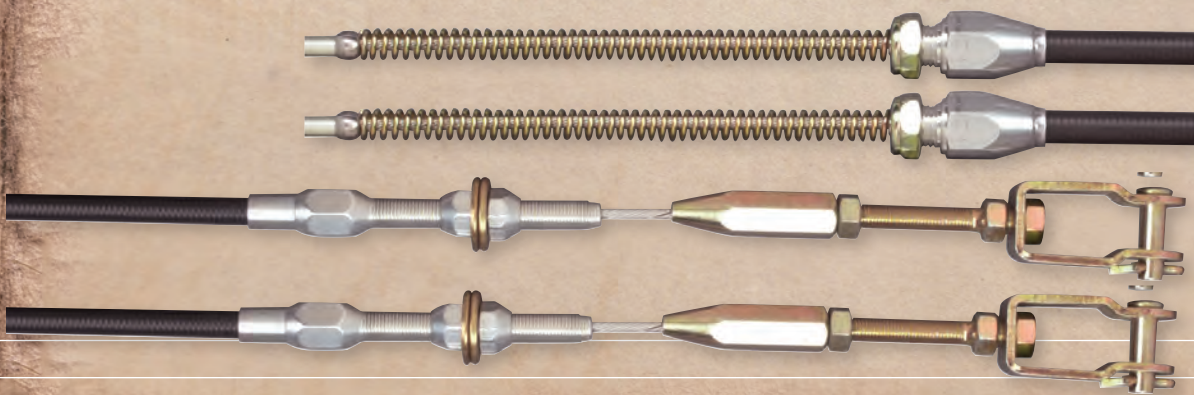

EC-8004U  
Black Housing  
(Pair)



## CONNECTOR CABLES FOR ORIGINAL FACTORY UNDER-THE-DASH HAND BRAKES

Lokar Connector Cables work in conjunction with Lokar's Universal Emergency Brake Cables and with stock under-the-dash hand brakes. Kit includes a single 6 foot outer housing designed with a specially extruded liner that "U-Cut-to-Fit" and a 7 foot stainless steel inner cable which resists moisture. Kit comes equipped with quality aluminum fittings and adjuster. Ferrule is included to eliminate fraying of stainless housing.

PART NO.	DESCRIPTION
EC-8000U	'37 to '48 Ford Black Connector Cable
EC-8000HT	'37 to '48 Ford Stainless Connector Cable
EC-8002U	'38 to '48 Plym/Dodge Black Connector Cable
EC-8002HT	'38 to '48 Plym/Dodge Stainless Connector Cable
EC-8003U	'39 to '48 Chevy Black Connector Cable
EC-8003HT	'39 to '48 Chevy Stainless Connector Cable



Use EC-80FU, EC-81FU, EC-80FHT or EC-81FHT Series Universal Brake Cable Kits with all Lokar Connector Cables. EC-8000U and EC-8000HT fit '37 to '48 Ford passenger cars & '37 to '56 Ford truck hand brakes.



1937 to 1948 Ford passenger cars and 1937 to 1956 Ford Trucks



1938 to 1948 Plymouth and Dodge



1939-1948 Chevy

## CONNECTOR CABLES FOR UNDER-THE-DASH FOOT OPERATED AND HAND OPERATED EMERGENCY BRAKES

Lokar Connector Cables are designed to mount directly to the Under-the-Dash Foot Operated Emergency Brake and Under-the-Dash Hand Operated Emergency Brake and connect up with Lokar Universal Brake Cables. Cables are "U-Cut-to-Fit" and are 6 feet in length. Available in black or stainless housing.

PART NO.	DESCRIPTION
EC-8001U	Connector Cable for Lokar Foot Operated and Hand Operated Emergency Brakes - Black Housing
EC-8001HT	Connector Cable for Lokar Foot Operated and Hand Operated Emergency Brakes - Stainless Housing



EC-8001U and EC-8001HT are for use with all styles of Lokar Under-the-Dash Hand and Foot Operated Emergency Brakes.



Cable can be routed inside the vehicle such as through the console, to keep cable out of sight for a cleaner undercarriage.



EC-8001U

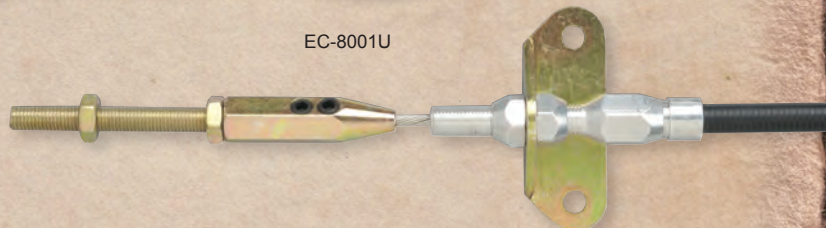

EC-8001HT

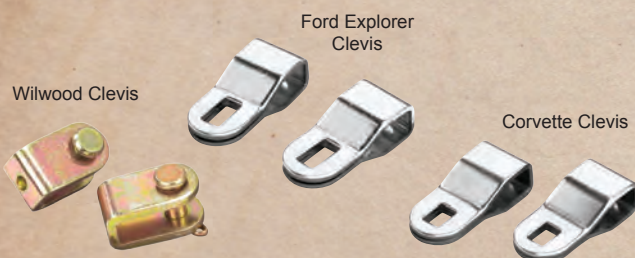

## REAR BRAKE CLEVIS KITS

Lokar Clevis Kits adapt Lokar Emergency Brake Cable Kits for 1984 - 1987 Corvette, 1988 and later Corvette, Jag rear with Wilwood, Wilwood Disc, Wilwood Ford Explorer style with internal hub rears, and Baer brakes.

PART NO.	DESCRIPTION
EC-80WC	Wilwood Clevis Kit (Wilwood stand alone Caliper, Jag with Wilwood and 1988 & later Corvette)
EC-80CC	Corvette Clevis Kit (1984 to 1987 Corvette and Baer Brakes)
EC-81FC	Wilwood/Ford Explorer Style Rear Clevis Kit



# Exterior Products

## Award Winning BILLET ALUMINUM OVAL LED TAILLIGHTS

### Features

- Chrome plated or black powder coated for ultimate shine and easy detailing
- CNC machined from 6061-T6 Billet Aluminum
- Bright LED lights for safety and function
- Integrated design with 3 functions: tail, turn, and brakes
- Extremely bright LEDs generate virtually no heat, use little power, and have long life
- Fully assembled for easy installation
- Detailed instructions with color coded wiring for easy installation
- Oval style with smooth recessed lens and internal prism
- Design matches other Lokar Oval style products
- Stainless hardware and zinc plated mounting brackets
- Low profile design
  - 1-1/4" total thickness
  - Requires a mere 1-1/2" behind body panel for mounting
  - Protrudes less than 3/16" from outside of body panel
- Offered in two sizes
  - Standard: Outer Bezel measures 2-3/4" x 5-1/2"
  - XL: Outer Bezel measures 3" x 6-1/2"



### PART NO. DESCRIPTION

TL-1910	Standard Billet Aluminum Oval LED Taillights (Pair) - Chrome
XTL-1910	Standard Billet Aluminum Oval LED Taillights (Pair) - Black
TL-1911	XL Billet Aluminum Oval LED Taillights (Pair) - Chrome
XTL-1911	XL Billet Aluminum Oval LED Taillights (Pair) - Black

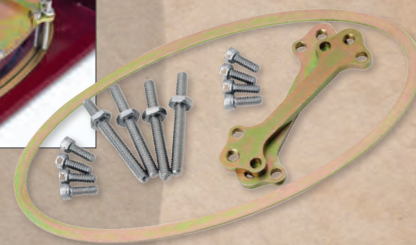
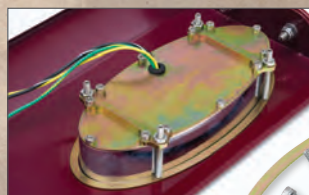

## ANCHOR-TIGHT® HEADLIGHT BRAID

No, this is not just another headlight conduit! This is Lokar's design technology for "U-Cut-to-Fit", non-kinking stainless steel headlight braid. Designed with threaded steel studs to insure that you won't experience any of the typical separation between braid and fitting that shows unsightly wires out in the open. Pull, tug or bump your headlight braid and it will stay in place, leaving you with protected wires and a clean set up. Kit comes complete with two 14" flexible braided stainless steel Teflon®-lined housings, threaded STEEL studs, billet aluminum fittings, aluminum grill shell washers and four 26" headlight wires.

### PART NO. DESCRIPTION

HL-1900	Anchor-Tight® Stainless Steel Headlight Braid
XHL-1900	Black Anchor-Tight® Stainless Steel Headlight Braid

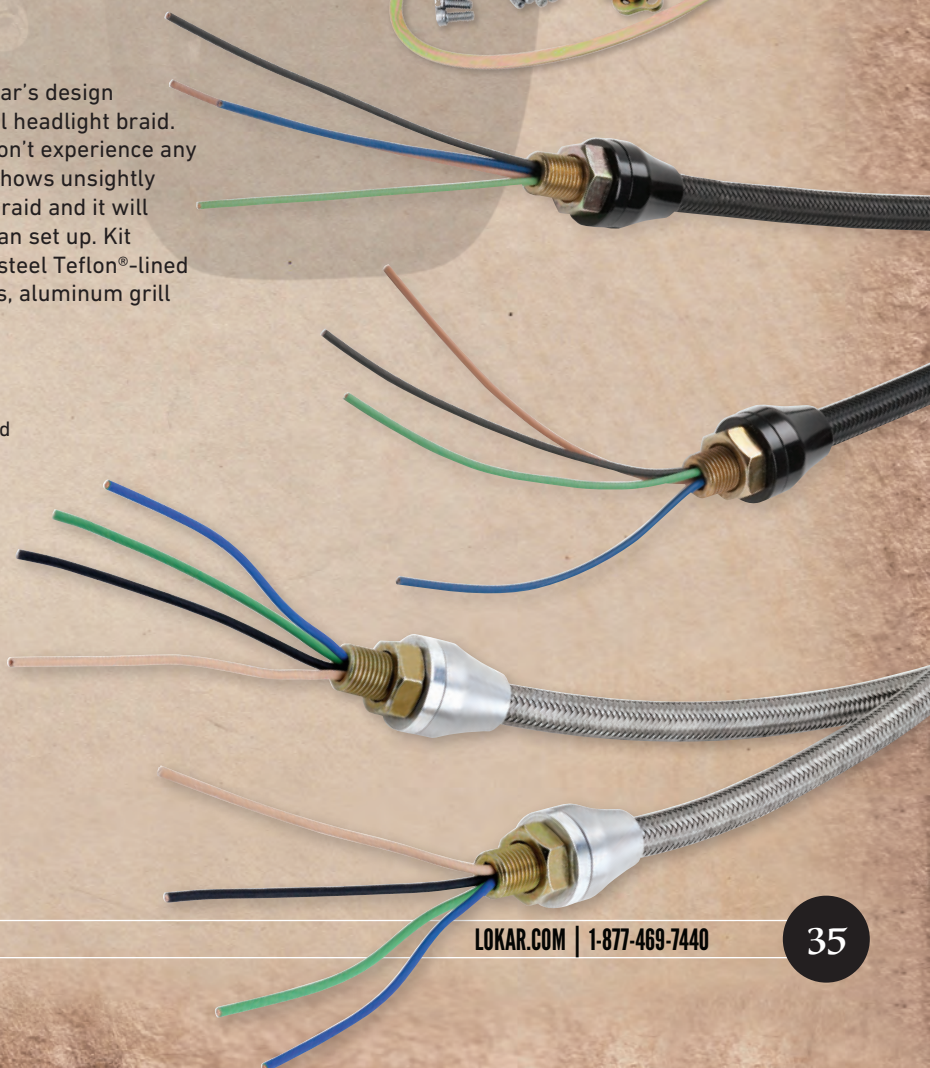



## BILLET EXTERIOR 12 VOLT DOOR HANDLES

Billet exterior 12 volt door handles are a great way to elevate your vehicle to the next level. Lokar's door handles utilize a 12 volt pressure pad switch to supply power to the electric actuated door latches.

The XL design provides 7/8" of clearance between the door and the switch, which allows for easier mounting without modifications to the door.

- Two piece design with removable insert for customization
- Weather proof 12 volt touch pad switch
- Available with a 0 or 10 degree mounting surface
- Machined from 6061-T-6 billet aluminum
- Stainless steel hardware included
- Available in brushed or polished finish



### PART NO. DESCRIPTION

GSE-2100	0 Degree Billet Exterior 12 Volt Door Handle - Brushed (Pair)
GSE-2101	0 Degree Billet Exterior 12 Volt Door Handle - Polished (Pair)
GSE-2102	10 Degree Billet Exterior 12 Volt Door Handle - Brushed (Pair)
GSE-2103	10 Degree Billet Exterior 12 Volt Door Handle - Polished (Pair)
GSE-2104	0 Degree Billet Exterior XL 12 Volt Door Handle - Brushed (Pair)
GSE-2105	0 Degree Billet Exterior XL 12 Volt Door Handle - Polished (Pair)
GSE-2106	10 Degree Billet Exterior XL 12 Volt Door Handle - Brushed (Pair)
GSE-2107	10 Degree Billet Exterior XL 12 Volt Door Handle - Polished (Pair)



The Billet Exterior 12 Volt Door Handles are designed to be used with a pocket for hand clearance. Choose the XL Handles for non-pocket installation.

## EARLY FORD RADIATOR CAP

Decorative Billet Aluminum Early Ford Radiator Cap with traditional styling.

- 2 1/4"-18 Thread Pitch
- Polished Finish
- '28-'29 Model A Radiators and aftermarket Walker Radiators with threaded stanchion

### PART NO. DESCRIPTION

DUK-2210	Early Ford Radiator Cap
----------	-------------------------







### GOOLSBY EDITION BILLET ALUMINUM HOOD VENTS

Universal Billet Aluminum Hood Vents for your muscle car or late model project car. Featured on the LokaRS '69 Camaro.

- Clamping Design
- Machined Finish
- All Hardware Included
- Ready To Paint, Powder Coat, Chrome-Plate, or Anodize
- Dissipates Heat
- Sold In Pairs

PART NO. DESCRIPTION

GSE-3000 Goolsby Edition Billet Aluminum Hood Vents (Pair)



### GOOLSBY EDITION BILLET ALUMINUM EXHAUST TIPS

Featured on the LokaRS '69 Camaro. Two piece Billet Aluminum Exhaust Tips with modern styling and curvature to match rear valance. Available in machined or polished finish. Fits up to a 3" exhaust, universal mounting options and v-band clamp adaptable. Provides the finishing touch to your exhaust.

PART NO. DESCRIPTION

GSE-3010 Goolsby Edition Billet Aluminum Exhaust Tips (Pair)





# Throttle Cables & Kickdowns

Stainless Steel Housing

Black Stainless Steel Housing

Black Housing

## HI-TECH THROTTLE CABLES

All Lokar Hi-Tech Throttle Cables are available in either stainless steel braided housing, black stainless steel braided housing or black housing. They are designed with a specially extruded liner for extended life of the cable – not to be confused with ordinary braided brake hose. Cables are equipped with aluminum fittings and aluminum ferrules to eliminate fraying. "U-Cut-to-Fit" outer housing is available in 24" or 36" lengths with a "U-Cut-to-Fit" stainless inner wire. Clevis is designed without cotter pins or set screws. Adapts to factory and aftermarket pedals. Custom lengths available upon request. Cables mount nicely with Lokar's array of Brackets and Return Springs (sold separately). Kits complete with installation instructions.

DESCRIPTION	STAINLESS STEEL HOUSING	BLACK SS HOUSING	BLACK HOUSING
24" Hi-Tech Throttle Cable	TC-1000HT	XTC-1000HT	TC-1000U
36" Hi-Tech Throttle Cable	TC-1000HT36	XTC-1000HT36	TC-1000U36
Tuned-Port '85-'91 & LT1/LT4 Hi-Tech Throttle Cable	TC-1000TP	XTC-1000TP	TC-1000TPU
Blower Drive Hi-Tech Throttle Cable	TC-1000BLD	XTC-1000BLD	TC-1000BLDU
36" LS1 Hi-Tech Throttle Cable (also use for Ram Jet 350)	TC-1000LS1	XTC-1000LS1	TC-1000LS1U
Ford EFI '94 & '95 only* Hi-Tech Throttle Cable	TC-1000EFI	XTC-1000EFI	TC-1000EFIU
36" Vortec Hi-Tech Throttle Cable	TC-1000TPV	XTC-1000TPV	TC-1000TPVU
Ford MOD 4.6, 5.4 V8 Hi-Tech Throttle Cable	TC-1000MOD	XTC-1000MOD	TC-1000MODU
24" Ram Jet 502 Hi-Tech Throttle Cable	TC-1000RJ	XTC-1000RJ	TC-1000RJU
Barry Grant Six Shooter Hi-Tech Throttle Cable	TC-1000BG	XTC-1000BG	TC-1000BGU
24" Borla 8-Stack Injection Throttle Cable	TC-1000B8	XTC-1000B8	N/A
36" Borla 8-Stack Injection Throttle Cable	TC-1000B836	XTC-1000B8826	N/A

For 1986 - 1993 EFI use TC-1000HT or TC-1000U.



**ORDERING TIP**

Don't forget to order the appropriate mounting bracket to mount our Throttle Cables and Hi-Tech Kickdowns (Page 45-49).



**INSTALL TIP**

Always use anti-seize on aluminum fittings to avoid galling. Remember to pull inner wire out before cutting outer housing.



Stainless Steel Housing



Black Stainless Steel Housing



Black Housing



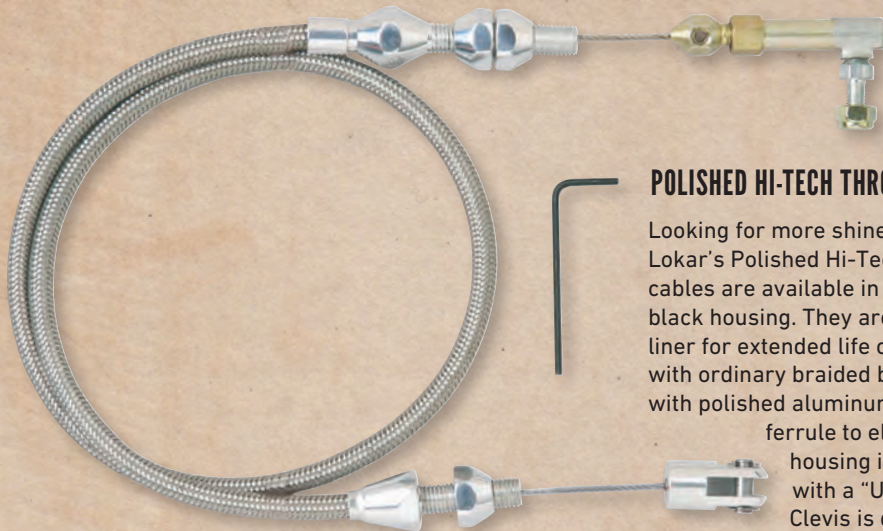

Polished Hi-Tech Throttle Cable Kit

### POLISHED HI-TECH THROTTLE CABLES

Looking for more shine in your engine compartment? Try Lokar's Polished Hi-Tech Throttle Cables. Lokar's polished cables are available in stainless steel braided housing or black housing. They are designed with a specially extruded liner for extended life of the cable – not to be confused with ordinary braided brake hose. Cables are equipped with polished aluminum fittings and polished aluminum ferrule to eliminate fraying. "U-Cut-to-Fit" outer housing is available in 24" or 36" lengths with a "U-Cut-to-Fit" stainless inner wire. Clevis is designed without cotter pins or set screws. Adapts to factory and aftermarket pedals. Custom lengths available upon request. Cables mount nicely with Lokar's array of Bracket and Return Springs (**sold separately**). Kits complete with installation instructions. Pair up with a Polished Kickdown (Page 41).



Polished Black Throttle Cable Kit

#### DESCRIPTION

	STAINLESS STEEL HOUSING	BLACK HOUSING
24" Hi-Tech Throttle Cable	TCP-1000HT	TCP-1000U
36" Hi-Tech Throttle Cable	TCP-1000HT36	TCP-1000U36
Tuned-Port '85-'91 & LT1/LT4 Hi-Tech Throttle Cable	TCP-1000TP	TCP-1000TPU
24" Blower Drive Hi-Tech Throttle Cable	TCP-1000BLD	TCP-1000BLDU
36" Blower Drive Hi-Tech Throttle Cable	TCP-1000BLD36	TCP-1000BLDU36
36" LS1 Hi-Tech Throttle Cable (also use for Ram Jet 350)	TCP-1000LS1	TCP-1000LS1U
Ford EFI '94 & '95 only* Hi-Tech Throttle Cable	TCP-1000EFI	TCP-1000EFIU
36" Vortec Hi-Tech Throttle Cable	TCP-1000TPV	TCP-1000TPVU
Ford MOD 4.6, 5.4 V8 Hi-Tech Throttle Cable	TCP-1000MOD	TCP-1000MODU
24" Ram Jet 502 Hi-Tech Throttle Cable	TCP-1000RJ	TCP-1000RJU
Barry Grant Six Shooter Hi-Tech Throttle Cable	TCP-1000BG	TCP-1000BGU

### DUO-PAK KITS

**SAVE** with Lokar's Duo-Pak Hi-Tech Throttle Cable Kits. The kit is equipped with a Throttle Cable in stainless or black housing **PLUS** our Stainless Steel Carburetor Bracket and Return Spring Kit. Duo-Pak only available for carbureted applications with Holley, Edelbrock, AFB, Quadrajet and In-Line Dual Quad carbs.

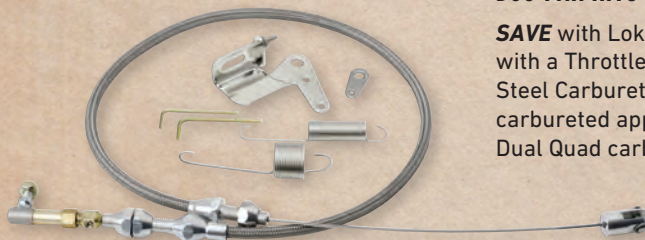

Duo-Pak Hi-Tech

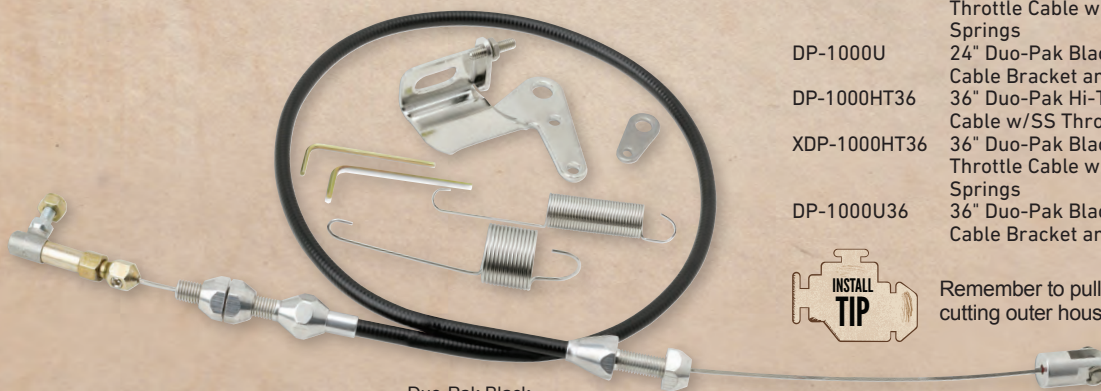

Duo-Pak Black

PART NO.	DESCRIPTION
DP-1000HT	24" Duo-Pak Hi-Tech Stainless Steel Throttle Cable w/SS Throttle Cable Bracket and Springs
XDP-1000HT	24" Duo-Pak Black Hi-Tech Stainless Steel Throttle Cable w/SS Throttle Cable Bracket and Springs
DP-1000U	24" Duo-Pak Black Throttle Cable w/SS Throttle Cable Bracket and Springs
DP-1000HT36	36" Duo-Pak Hi-Tech Stainless Steel Throttle Cable w/SS Throttle Cable Bracket and Springs
XDP-1000HT36	36" Duo-Pak Black Hi-Tech Stainless Steel Throttle Cable w/SS Throttle Cable Bracket and Springs
DP-1000U36	36" Duo-Pak Black Throttle Cable w/SS Throttle Cable Bracket and Springs



Remember to pull inner wire out before cutting outer housing.





## HI-TECH BLOWER DRIVE THROTTLE CABLES AND KICKDOWNS

Blower Drive Cables are designed to operate with BDS linkage, Enderle linkage, and Weiand linkage for side mounted carburetors. Throttle cables designed with a specially extruded liner for extended life of the cable— not to be confused with ordinary braided brake hose. Cables are equipped with aluminum fittings and aluminum ferrule to eliminate fraying. "U-Cut-to-Fit" outer housing is available in 24" or 36" lengths with a "U-Cut-to-Fit" stainless inner wire. Blower Throttle Cable comes complete with stainless mounting bracket and rod end. Kickdowns are designed with the same quality as our carbureted applications and are available for all transmission applications.

DESCRIPTION	STAINLESS STEEL HOUSING	BLACK SS HOUSING	BLACK HOUSING
24" Blower Drive Throttle Cable	TC-1000BLD	XTC-1000BLD	TC-1000BLDU
36" Blower Drive Throttle Cable	TC-1000BLD36	XTC-1000BLD36	TC-1000BLDU36
Blower Drive Hi-Tech TH350 Stainless Steel Kickdown	KD-2350BLD	XKD-2350BLD	KD-2350BLDU
Blower Drive Hi-Tech TH400 Stainless Steel Kickdown	KD-2400BLD	XKD-2400BLD	KD-2400BLDU
Blower Drive Hi-Tech TH200 Stainless Steel Kickdown	KD-2200BLD	XKD-2200BLD	KD-2200BLDU
Blower Drive Hi-Tech 700 Stainless Steel Kickdown	KD-2700BLD	XKD-2700BLD	KD-2700BLDU
Blower Drive Hi-Tech 200-4R Stainless Steel Kickdown	KD-2200RBLD	XKD-2200RBLD	KD-2200RBLDU
Blower Drive Hi-Tech 4L60 Stainless Steel Kickdown	KD-24L60BLD	XKD-24L60BLD	KD-24L60BLDU
Blower Drive Hi-Tech 518 Stainless Steel Kickdown	KD-2518BLD	XKD-2518BLD	KD-2518BLDU
Blower Drive Hi-Tech 727 Stainless Steel Kickdown	KD-2727BLD	XKD-2727BLD	KD-2727BLDU
Blower Drive Hi-Tech AOD Stainless Steel Kickdown	KD-2A0DBLD	XKD-2A0DBLD	KD-2A0DBLDU
Blower Drive Hi-Tech C4 Stainless Steel Kickdown	KD-20C4BLD	XKD-20C4BLD	KD-20C4BLDU
Blower Drive Hi-Tech C6 Stainless Steel Kickdown	KD-20C6BLD	XKD-20C6BLD	KD-20C6BLDU
Blower Drive Hi-Tech PowerGlide Stainless Steel Kickdown	KD-20PGBLD	XKD-20PGBLD	KD-20PGBLDU



Remember to pull inner wire out before cutting outer housing.

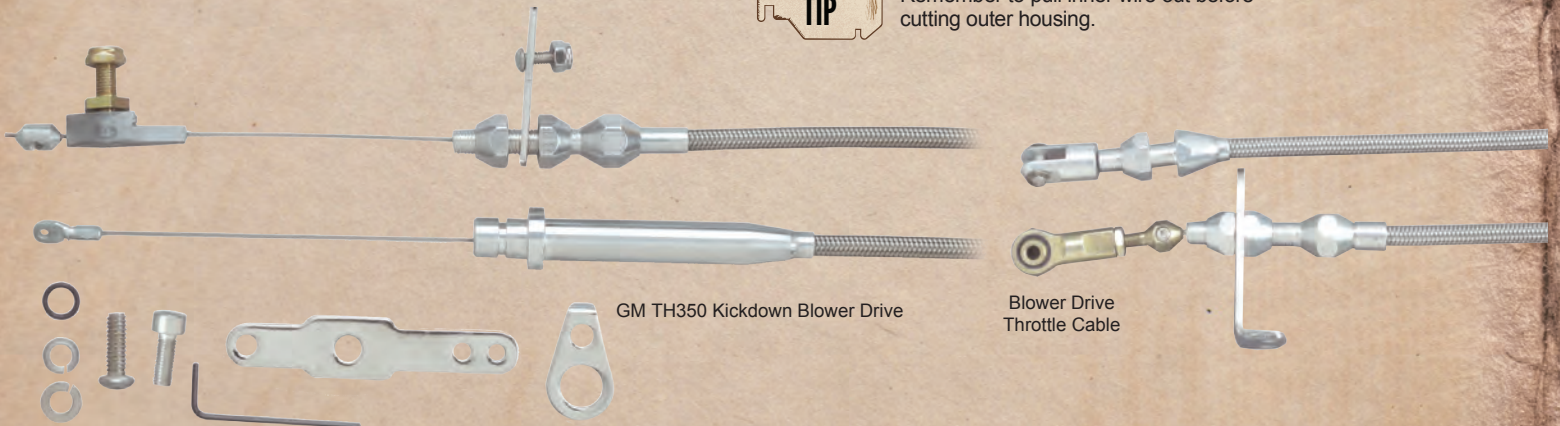

GM TH350 Kickdown Blower Drive

Blower Drive Throttle Cable



## HI-TECH KICKDOWN KITS

Lokar's "U-Cut-to-Fit" Hi-Tech Kickdown Cables are available in either stainless steel braided housing, black stainless steel braided housing or black housing. They are designed with a specially extruded liner for extended life of the cable – not to be confused with ordinary brake hose. Kickdown features aluminum fittings with ferrule to eliminate frayed cable ends. Kickdowns are adaptable for all types of manifolds including tunnel ram, blower manifolds and Weber induction systems. Mount our kickdown with our Stainless Steel Carburetor Bracket and Return Springs (sold separately). Complete instructions included in kit.

Hi-Tech TH350 Kickdown Kit

Black TH350 Kickdown Kit

Black Stainless Steel TH350 Kickdown Kit

TRANSMISSION	STAINLESS STEEL HOUSING	BLACK SS HOUSING	BLACK HOUSING
GM TH350	KD-2350HT	XKD-2350HT	KD-2350HTBlack
GM TH350 Tuned-Port	KD-2350TP	XKD-2350TP	KD-2350TPU
GM TH350 Blower Drive	KD-2350BLD	XKD-2350BLD	KD-2350BLDU
GM Powerglide	KD-20PGHT	XKD-20PGHT	KD-20PGU
GM 700-R4	KD-2700HT	XKD-2700HT	KD-2700U
GM 700-R4 Tuned-Port	KD-2700TP	XKD-2700TP	KD-2700TPU
GM TH200 (1976-1978)	KD-2200HT	XKD-2200HT	KD-2200U
GM 200-4R (1979-1989)	KD-2200RHT	XKD-2200RHT	KD-2200RU
GM 4L60	KD-24L60HT	XKD-24L60HT	KD-24L60U
GM 4L60 Tuned-Port	KD-24L60TP	XKD-24L60TP	KD-24L60TPU
Ford C4	KD-20C4HT	XKD-20C4HT	KD-20C4U
Ford C4 Tuned-Port	KD-20C4TP	XKD-20C4TP	KD-20C4TPU
Ford C6	KD-20C6HT	XKD-20C6HT	KD-20C6U
Ford FMX	KD-2FMXHT	XKD-2FMXHT	KD-2FMXU
Ford AOD	KD-2AODHT	XKD-2AODHT	KD-2AODU
Chrysler 727	KD-2727HT	XKD-2727HT	KD-2727U
Chrysler 904	KD-2904HT	XKD-2904HT	KD-2904U
Chrysler 518	KD-2518HT	XKD-2518HT	KD-2518U



Always use anti-seize on aluminum fittings to avoid galling. Remember to pull inner wire out before cutting outer housing.

## POLISHED HI-TECH KICKDOWN KITS

To add more shine to your engine compartment, try Lokar's "U-Cut-to-Fit" Polished Kickdown Cables which are available in either stainless steel braided housing or black housing. Cables are designed with a specially extruded liner for extended life of the cable – not to be confused with ordinary brake hose. Kickdown features polished aluminum fittings with polished ferrule to eliminate frayed cable ends. Kickdowns are adaptable for all types of manifolds including tunnel ram, blower manifolds and Weber induction systems. Mount our kickdown with our Stainless Steel Carburetor Bracket and Return Springs (sold separately). Complete instructions included in kit. Pair up with Polished Throttle Cable (Page 33).

Polished Hi-Tech TH350 Kickdown Kit

Polished Hi-Tech Black TH350 Kickdown Kit

TRANSMISSION	STAINLESS STEEL HOUSING	BLACK HOUSING
GM TH350	KDP-2350HT	KDP-2350HTBlack
GM TH350 Tuned-Port	KDP-2350TP	KDP-2350TPU
GM TH350 Blower Drive	KDP-2350BLD	KDP-2350BLDU
GM Powerglide	KDP-20PGHT	KDP-20PGU
GM 700-R4	KDP-2700HT	KDP-2700U
GM 700-R4 Tuned-Port	KDP-2700TP	KDP-2700TPU
GM TH200	KDP-2200HT	KDP-2200U
GM 200-4R	KDP-2200RHT	KDP-2200RU
GM 4L60	KDP-24L60HT	KDP-24L60U
GM 4L60 Tuned-Port	KDP-24L60TP	KDP-24L60TPU
Ford C4	KDP-20C4HT	KDP-20C4U
Ford C4 Tuned-Port	KDP-20C4TP	KDP-20C4TPU
Ford C6	KDP-20C6HT	KDP-20C6U
Ford FMX	KDP-2FMXHT	KDP-2FMXU
Ford AOD	KDP-2AODHT	KDP-2AODU
Chrysler 727	KDP-2727HT	KDP-2727U
Chrysler 904	KDP-2904HT	KDP-2904U
Chrysler 518	KDP-2518HT	KDP-2518U



## THROTTLE BODY & CARB END FITTINGS

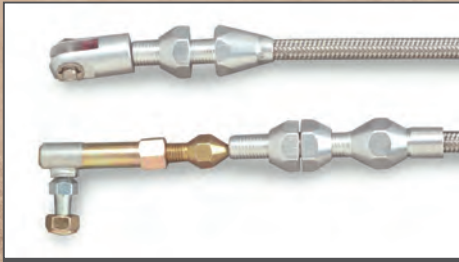

Carbureted & Ford EFI '86-'93

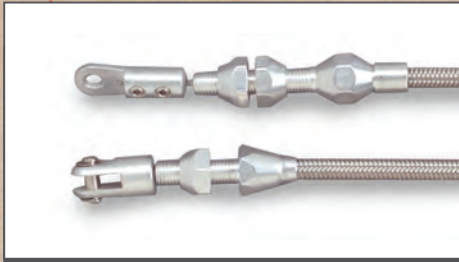

TPI '88 & earlier



LS1, Vortec and Ram Jet 350

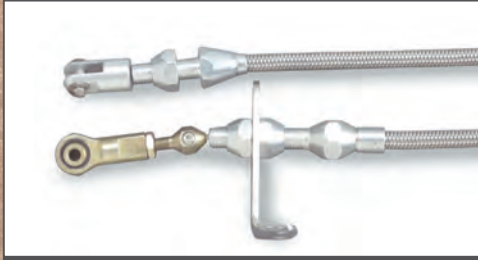

Blower Drive

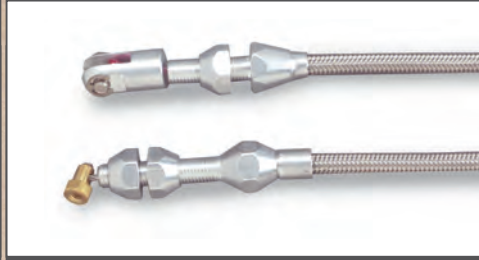

TPI '89 & later, LT1 & LT4



Ford EFI '94 & '95

## LOKAR KICKDOWN END FITTINGS

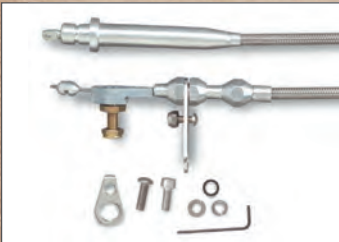

GM TH350 & TH200

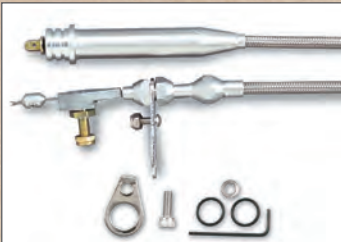

GM 700-R4, 200-4R, 4L60

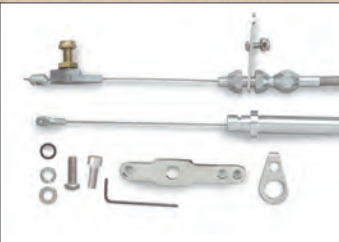

GM TH350 Blower Drive



GM Powerglide

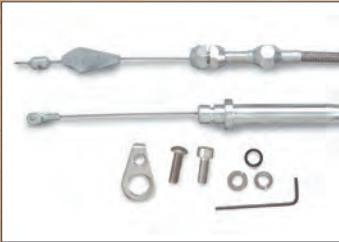

GM TH350 TPI

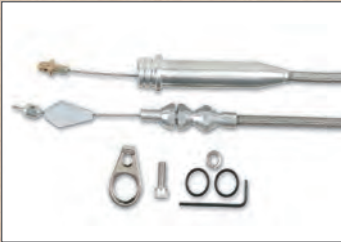

GM 700-R4, 200-4R, 4L60 TPI



Ford C4

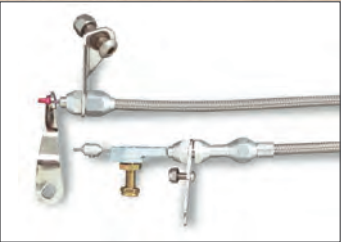

Ford C6

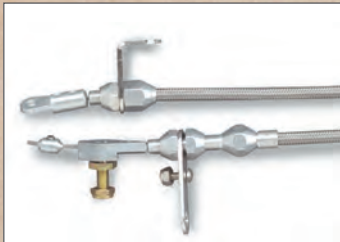

Ford FMX



Ford AOD

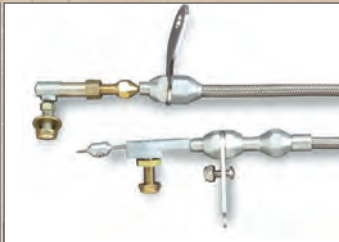

Chrysler 727, 904 & 518







Black Stainless Steel TH400 Electric Kickdown Kit

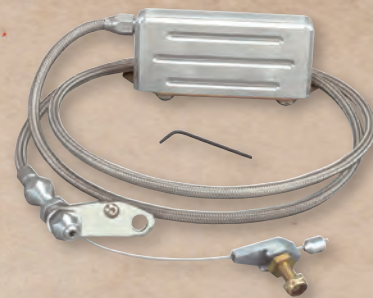

Hi-Tech TH400 Electric Kickdown Kit



Black TH400 Electric Kickdown Kit

### HI-TECH TH400 ELECTRIC KICKDOWN KIT

Lokar's Hi-Tech TH400 Electric Kickdown is cable-operated. The electric switch is housed in a billet aluminum box that mounts with transmission pan bolts.\* Kit includes "U-Cut-to-Fit" outer housing in stainless steel, black stainless steel or black. Designed with a specially extruded liner for extended life of the cable, aluminum fittings and stainless steel inner wire and stainless mounting bracket. Mount the kickdown with our Stainless Steel Carburetor Bracket and Return Springs (sold separately). This design eliminates mounting unsightly electrical switches on carburetor, manifold, or near throttle pedal. Complete installation instructions included in kit.

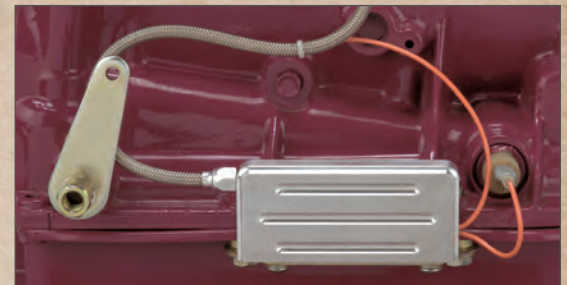

**ORDERING TIP**

Don't forget to order one of our many brackets to mount our Throttle Cables and Hi-Tech Kickdowns! (See pages 38-42)



**INSTALL TIP**

Hi-Tech TH 400 Electric Kickdown be mounted in a variety of locations within 48" of carburetor. Remember to pull inner wire out before cutting outer housing.

PART NO.	DESCRIPTION
KD-2400HT	Hi-Tech TH400 Electric Kickdown
KD-2400U	Black TH400 Electric Kickdown
XKD-2400HT	Black Hi-Tech GM TH400 Electric Kickdown
KDP-2400HT	Polished Hi-Tech TH400 Electric Kickdown
KDP-2400U	Polished Black TH400 Electric Kickdown

### TH350 STAINLESS KICKDOWN BRACKET & CABLE

Standard adjustable GM detent (black housing) with Lokar's stainless mounting bracket mounts onto the back two manifold bolts. Designed for 4 barrel-type carburetors for small block Chevys. Kit includes extender for more versatility in adjusting cable length where needed. Stainless bracket also sold separately. Note: Cable housing cannot be cut to fit.



PART NO.	DESCRIPTION
KD-2350U	TH350 Stainless Kickdown Bracket & Cable
KDB-4350	TH350 Stainless Kickdown Bracket Only
XKDB-4350	Black TH350 Stainless Kickdown Bracket Only



Brackets available separately

GM detent cannot be cut to fit

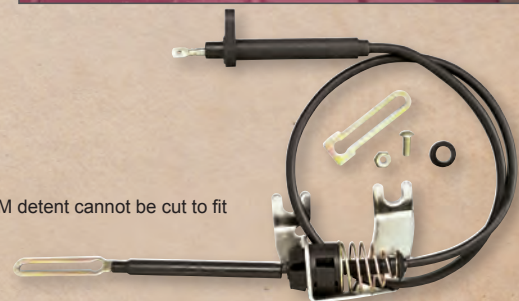



## U-CUT-TO-FIT CRUISE CONTROL CABLES

Lokar Cruise Control Cable is for use with "Rostra" Control kits. Kit includes 4' stainless outer housing designed with a specially extruded liner for extended life of the cable and 5' of stainless inner wire, which replaces the black plastic cable in Rostra Kits. Cables are "U-Cut-to-Fit" inside and outside of firewall. All billet aluminum fittings with stainless hold down clamp and mounting bracket.

PART NO.	DESCRIPTION
CC-1600U	Carbureted Cruise Control Cable - Black
CC-1601HT	Carbureted Cruise Control Cable - Stainless
CC-1602U	Tuned-Port Cruise Control Cable - Black
CC-1603HT	Tuned-Port Cruise Control Cable - Stainless
XCC-1601HT	Cruise Control Cable Black SS Housing w/Black Aluminum Fittings
XCC-1603HT	Tuned-Port Cruise Control Cable Black SS Housing w/Black Aluminum Fittings



Rostra Control

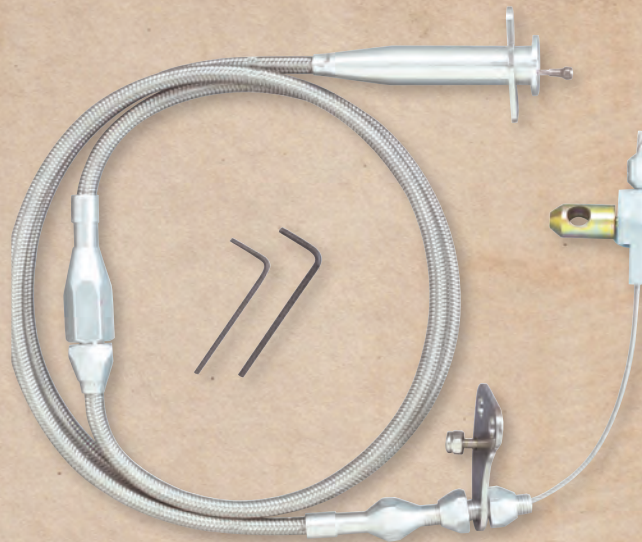

CC-1601HT

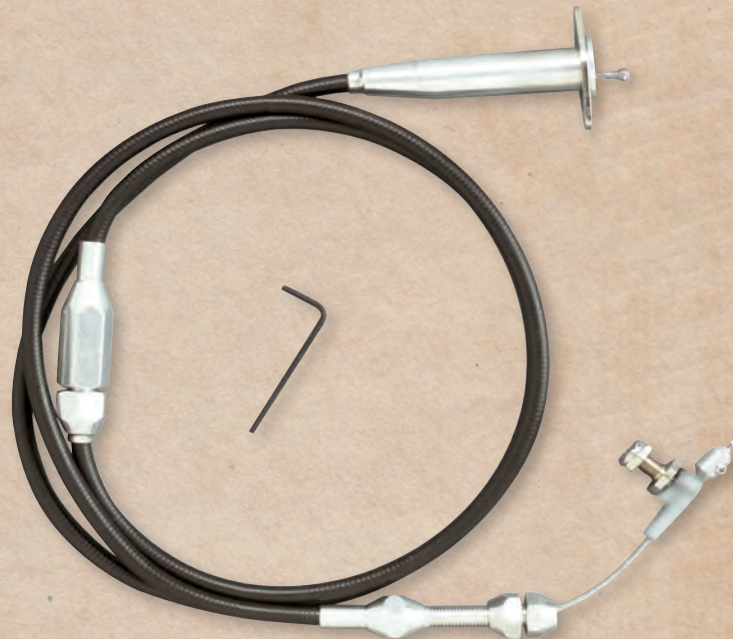

CC-1602U



Mount cable to carburetor with Lokar's Stainless Carburetor Bracket and Return Springs, Part No. SRK-4000.

## SPARE THROTTLE CABLE COMPONENT PARTS



Throttle Cable Inner Wire for Lokar Cables  
Part # S-1041 36"  
Part # S-1042 48"



Carb End for Lokar Throttle Cables  
Part # S-1034

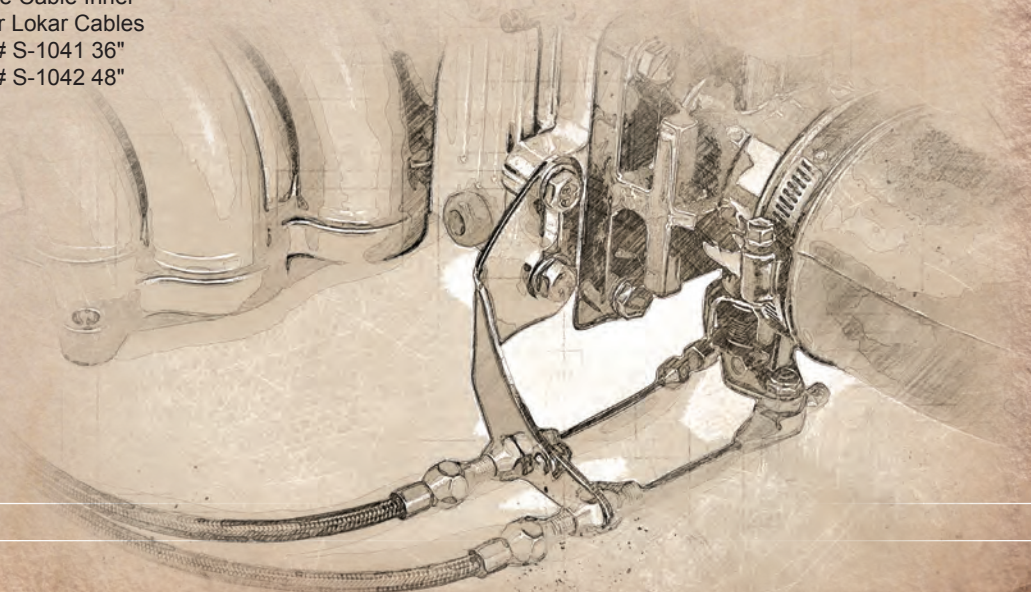



# Throttle Cable Bracket and Spring Kits

## STAINLESS STEEL CARBURETOR BRACKET & RETURN SPRINGS

Stainless bracket mounts to rear of Holley, Edelbrock, AFB, Quadrajet, Demon (excludes Street Demon), and In-Line Dual Quads. Stainless bracket and GM designed dual stainless springs are used to mount Lokar's Throttle Cable and Kickdown kits. Design provides improved clearance on Edelbrock carbs. Design includes tension screw to prevent bracket from movement under extreme pressure on a kickdown cable, such as with a 700-R4 transmission.



PART NO.	DESCRIPTION
SRK-4000	Stainless Steel Carburetor Bracket and Stainless Springs
XSRK-4000	Black SS Carb Bracket & Black Stainless Springs
SRK-4001	Stainless Steel Carburetor Bracket
XSRK-4001	Black Stainless Steel Carburetor Bracket
SRK-4002	Stainless Steel Springs
XSRK-4002	Black Stainless Steel Springs

## TUNED-PORT BRACKETS

The billet aluminum bracket mounts to the side of the Tuned-Port plenum. The billet aluminum bracket is available with a single stud for throttle only, double stud for throttle and kickdown, and triple stud for a throttle, kickdown and cruise control cable.



'88 and earlier throttle body end fitting shown

PART NO.	DESCRIPTION
TCB-40TP1	Tuned-Port Billet Aluminum Bracket w/Single Stud
TCB-40TP2	Tuned-Port Billet Aluminum Bracket w/Double Stud
TCB-40TP3	Tuned-Port Billet Aluminum Bracket w/Triple Stud
XTCB-40TP1	Black Tuned-Port Billet Aluminum Bracket With Single Stud
XTCB-40TP2	Black Tuned-Port Billet Aluminum Bracket With Double Stud
XTCB-40TP3	Black Tuned-Port Billet Aluminum Bracket With Triple Stud
TCB-40TP1P	Polished Tuned-Port Billet Aluminum Bracket Single Stud
TCB-40TP2P	Polished Tuned-Port Billet Aluminum Bracket Double Stud
TCB-40TP3P	Polished Tuned-Port Billet Aluminum Bracket Triple Stud



Available with Single, Double or Triple Stud



## LT1 AND LT4 BRACKET KITS

Lokar's answer to LT1 cable problems. Stainless Throttle and Kickdown Brackets replace factory brackets. Kit includes stainless arm to mount on LT1 throttle body to operate kickdown. Designed to be used with Lokar's Tuned-Port Throttle Cables and Tuned-Port Kickdowns.

PART NO.	DESCRIPTION
TCB-40LT1	1992 -1993 LT1 Throttle Cable and Kickdown Cable Brackets
TCB-40LT4	1994 & Later LT1 & LT4 Throttle Cable & Kickdown Cable Brackets
TCB-40LTC	1992 & Later LT1 Cruise Control Bracket Kit
XTCB-40LT1	Black Stainless Steel 1992-1993 LT-1 Throttle Cable & Kickdown Cable Bracket
XTCB-40LT4	Black Stainless Steel 1994 & Later LT1 & LT4 Throttle Cable & Kickdown Cable Bracket



LT1 / LT4 Installation Example



TCB-40LTC



TCB-40LT1



XTCB-40LT4



TCB-40LT4





## LS1 BRACKETS

The billet aluminum bracket mounts to the side of the LS1 manifold and is available with a single stud for throttle only or a double stud to add a cruise control cable.

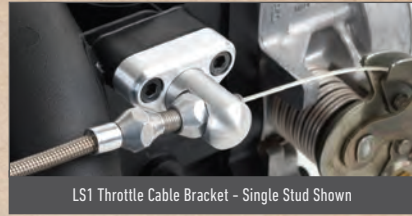

PART NO.	DESCRIPTION
TCB-40LS1	LS1 Throttle Cable Bracket (Single Stud) (1998-1999 GM Throttle Body with 3" linkage cam)
TCB-40LS12	LS1 Throttle Cable and Cruise Control Cable Bracket (Double Stud) (1998-1999 GM Throttle Body with 3" linkage cam)
TCB-40LS13	LS1 Throttle Cable Bracket (Single Stud) (2000-2002 GM and 2004 GTO Throttle Body with 3-1/2" linkage cams)
TCB-40LS14	LS1 Throttle Cable and Cruise Control Cable Bracket (Double Stud) (2000-2002 GM and 2004 GTO Throttle Body with 3-1/2" linkage cams)
XTCB-40LS1	Black LS1 Throttle Cable Bracket 1998- 1999 GM Throttle Body 3" Linkage Cam (Single Stud)
XTCB-40LS12	Black LS1 Throttle Cable & Cruise Control Bracket 1998-1999 GM Throttle Body 3" Linkage Cam (Double Stud)
XTCB-40LS13	Black LS1 Throttle Cable Bracket 2000-2002 GM & 2004 GTO Throttle Body 3-1/2" Linkage Cam (Single Stud)
XTCB-40LS14	Black LS1 Throttle Cable & Cruise Control Bracket 2000-2002 GM & 2004 GTO Throttle Body 3-1/2" Linkage Cam (Double Stud)

## RAM JET BRACKETS

Brackets fit the GM Ram Jet engine. These brackets along with Lokar Throttle Cables will allow the Ram Jet to work properly in any vehicle. When used with an automatic transmission, be sure to use the transmission specific Lokar Kickdown Cable.

### PART NO. DESCRIPTION

- TCB-40RJ Stainless Ram Jet Throttle Cable Brackets - Small Block 350
- TCB-40RJ1 Stainless Ram Jet Throttle Bracket & Stainless Springs - Big Block 502
- XTCB-40RJ Black Stainless Steel Ram Jet Throttle Cable Bracket - Small Block 350
- XTCB-40RJ1 Black Stainless Steel 502 Ram Jet Bracket & Black Stainless Steel Springs



350 Ram Jet uses TC-1000LS1 Throttle Cable  
502 Ram Jet uses TC-1000RJ Throttle Cable

## THROTTLE/KICKDOWN CABLE BRACKET FOR EDELBROCK PRO-FLO® XT

The Lokar Throttle/Kickdown Cable Bracket for Edelbrock Pro-Flo® XT features durable Stainless Steel construction. The bracket allows for easy installation of the Lokar LS1 Throttle Cable and Kickdown kit.

### PART NO. DESCRIPTION

- TCB-40EDXT Edelbrock Pro-Flo® XT Throttle Cable Bracket Kit
- XTCB-40EDXT Black Edelbrock Pro-Flo® XT Throttle Cable Bracket Kit





## EFI BRACKETS

Ford EFI Bracket fits 1986 to 1993 Ford 302 and 351 electronic fuel injection systems that have installed the Mustang EGR spacer. This Stainless Bracket mounts in stock location for easy installation of our Kickdown Cables and Throttle Cables. (1986 to 1993 uses TC-1000HT) **The EFI Bracket does not fit B.A.P. throttle bodies.**



PART NO.	DESCRIPTION
TCB-40EFI	Stainless Steel EFI Throttle Cable Bracket '86-'93 with Mustang EGR Spacer
XTCB-40EFI	Black Stainless Steel Ford EFI Throttle Cable Bracket '86-'93 with Mustang EGR Spacer



Use with Lokar Throttle Cable TC-1000HT, TC-1000U

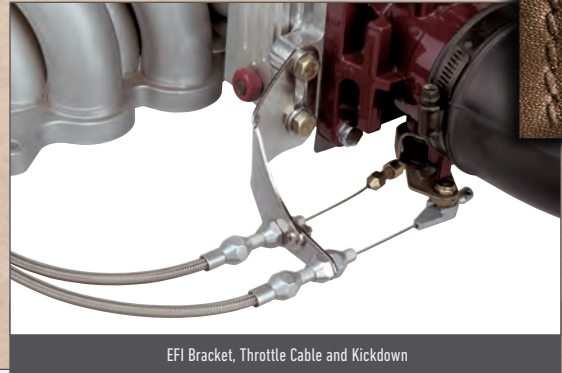

EFI Bracket, Throttle Cable and Kickdown

Carburetors courtesy of HotRodCarbs.com



## TRI-POWER BRACKET & SPRING KITS

Designed for Rochester Tri-Power. Kit includes Stainless Steel Throttle Cable Bracket and Stainless Steel Springs. Stainless bracket mounts under rear carburetor on Rochester 3-2 set-up. Cables operate from center carburetor. Stainless Bracket and Dual Stainless Springs are used to mount Lokar's Throttle Cable and Kickdown assemblies.

PART NO.	DESCRIPTION
TRP-4003	Stainless Steel Tri-Power Throttle Cable Bracket and Stainless Springs
TRP-4004	Stainless Steel Tri-Power Bracket only
TRP-4005	Stainless Steel Pontiac Tri-Power Throttle Cable Bracket & Stainless Springs
XTRP-4003	Black Stainless Steel Tri-Power Throttle Cable Bracket & Black Stainless Springs
XTRP-4004	Black Stainless Steel Tri-Power Bracket only
XTRP-4005	Black Stainless Steel Pontiac Tri-Power Bracket and Springs



## THROTTLE/KICKDOWN CABLE MOUNTING BRACKET FOR STROMBERG® STYLE CARBURETORS

- Stainless steel construction
- Allows easy mounting of Lokar Throttle and Kickdown Cables
- Dual stainless steel return springs
- Fits Stromberg 97®, Speedway "9 Super 7"®, Ford/Holley 94 and Edelbrock 94 carburetors with the 3 bolt base

PART NO.	DESCRIPTION
TRP-4006	Stainless Steel 3 Bolt Stromberg® Style Carburetors Tri-Power Throttle Cable Bracket & Springs
TRP-4007	Stainless Steel 3 Bolt Stromberg® Style Carburetors Tri-Power Throttle Bracket
XTRP-4006	Black Stainless Steel 3 Bolt Stromberg® Style Carburetors Tri-Power Throttle Cable Bracket & Springs
XTRP-4007	Black Stainless Steel 3 Bolt Stromberg® Style Carburetors Tri-Power Throttle Bracket

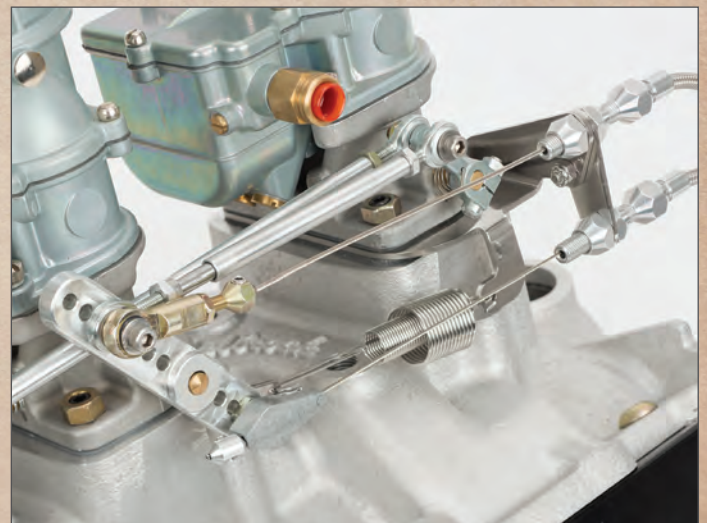



## THROTTLE CABLE MOUNTING BRACKET & SPRING RETURN KIT FOR 4150 SERIES CARBURETORS

Intended for street applications, the kit includes throttle cable and transmission kickdown cable provisions. Works with Lokar throttle and kickdown cables. Includes stainless steel return springs with dual wound ends for safety and also has adjustable spring tension. Fits most drop base air cleaners. Works with single or dual plane intake manifolds.

PART NO.	DESCRIPTION
----------	-------------

TCB-4150	Billet Aluminum Throttle Plate with Kickdown & Spring Return Kit Brushed
XTCB-4150	Black Billet Aluminum Throttle Plate with Kickdown & Spring Return Kit

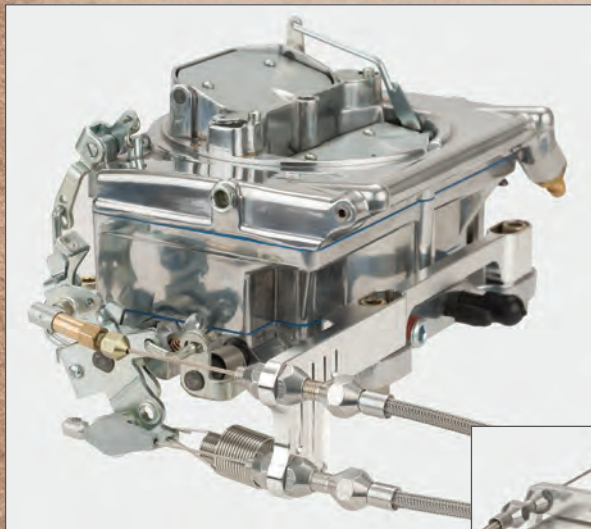

## THROTTLE/KICKDOWN CABLE MOUNTING BRACKET FOR STREET DEMON™ CARBURETORS

The Lokar Billet Aluminum Throttle/Kickdown Cable Mounting Bracket for Street Demon™ Carburetors is CNC machined from 6061-T6 billet aluminum. It provides easy installation of Lokar's Throttle and Kickdown Cables. The product features dual stainless steel return springs and comes recommended by Holley.

PART NO.	DESCRIPTION
----------	-------------

TCB-40SD	Billet Aluminum Street Demon™ Bracket for Throttle & Kickdown
TCB-40SD1	Billet Aluminum Street Demon™ Bracket for TPS
XTCB-40SD	Black Billet Aluminum Street Demon™ Bracket for Throttle & Kickdown
XTCB-40SD1	Black Billet Aluminum Street Demon™ Bracket for TPS



Also available to hold the TPS Sensor

## BILLET ALUMINUM THROTTLE/KICKDOWN BRACKET KIT FOR BARRY GRANT SIX SHOOTER

### FEATURES

- CNC machined from 6061-T6 billet aluminum for strength and style
- Easy installation of Lokar Throttle Cable and Kickdown kits
- Dual Stainless Steel Return Springs
- All hardware and detailed mounting instructions included
- Utilizes existing BG Six Shooter Progressive Linkage

PART NO.	DESCRIPTION
----------	-------------

TCB-40BG	Billet Aluminum BG Six Shooter Throttle/Kickdown Bracket and Stainless Springs - Fits Small Block Chevy
TCB-BG440	Billet Aluminum BG Six Shooter 440 Mopar Throttle/Kickdown Bracket and Stainless Springs
XTCB-40BG	Black Billet Aluminum Barry Grant Six Shooter Throttle/Kickdown Bracket & Springs - Fits Small Block Chevy
XTCB-BG440	Black Billet Aluminum Barry Grant Six Shooter 440 Mopar Throttle/Kickdown Bracket & Springs

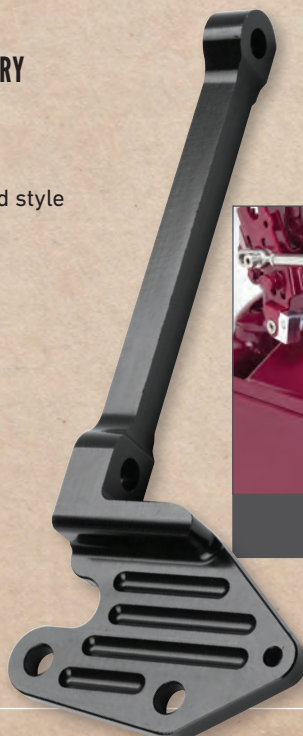

Throttle/Kickdown Bracket Kit for Barry Grant Six Shooter (Small Block Chevy Shown)



## BILLET ALUMINUM THROTTLE/KICKDOWN CABLE MOUNTING BRACKET FOR EDELBROCK 4-BARREL CARBURETORS

### FEATURES

- CNC machined from 6061-T6 billet aluminum for strength and style
- Bracket designed to fit single or dual quad carbs
- Easy installation of Lokar Throttle Cable and Kickdown kits
- Dual Stainless Steel Return Springs
- All hardware and detailed mounting instructions included
- Recommended by Edelbrock
- Attaches to both rear carb bolts to eliminate bracket movement
- Bracket utilizes either bolt pattern offered on Edelbrock carbs & manifolds

### PART NO. DESCRIPTION

TCB-40DQ	Billet Aluminum Edelbrock Carb Bracket and Stainless Springs
TCB-40DQ1	Billet Aluminum Edelbrock Carb Bracket & Springs with Progressive Linkage Rod For Edelbrock Carbs Center Distance 6-3/8" - 6-3/4"
XTCB-40DQ	Black Billet Aluminum Edelbrock Carburetor Bracket & Springs
XTCB-40DQ1	Black Billet Aluminum Edelbrock Carburetor Bracket & Springs with Progressive Linkage Rod For Edelbrock Carbs Center Distance 6-3/8" - 6-3/4"



Throttle Cable Mounting Bracket for Edelbrock 4-Barrel Carburetors



Mounting Brackets



Throttle/Kickdown Bracket & Spacer Kit for Edelbrock Pro-Flo® Fuel Injection

## BILLET ALUMINUM THROTTLE/KICKDOWN BRACKET & SPACER KIT FOR EDELBROCK PRO-FLO® FUEL INJECTION

### FEATURES

- CNC machined from 6061-T6 billet aluminum for strength and style
- Dual Stainless Steel Return Springs
- Easy installation of Lokar Throttle Cable and Kickdown kits
- All hardware and detailed mounting instructions included
- Recommended by Edelbrock
- For Small Block Chevy

### PART NO. DESCRIPTION

TCB-40ED	Edelbrock Pro-Flo® Injection Spacer Only
TCB-40EDK	Edelbrock Pro-Flo® Injection Spacer/Throttle/Kickdown Bracket and Spring Return Kit
TCB-40EDC	Edelbrock Pro-Flo® Injection Spacer/Throttle/Kickdown/Cruise Bracket and Spring Return Kit
XTCB-40ED	Black Billet Aluminum Edelbrock Pro-Flo® Spacer Only
XTCB-40EDK	Black Billet Aluminum Edelbrock Pro-Flo® Injection Spacer/Throttle/Kickdown Bracket & Black Spring Return Kit
XTCB-40EDC	Black Billet Aluminum Edelbrock Pro-Flo® Injection Spacer/Throttle/Kickdown/Cruise Bracket & Black Spring Return Kit

## BILLET ALUMINUM PROGRESSIVE LINKAGE SYSTEM

### FEATURES

- Progressive Linkage for in-line dual carburetors
- Design allows the use of only one carb during normal driving conditions and both carburetors at wide open throttle
- Available in Midnight Series™
- **Measure distance between air cleaner posts to determine correct length.**

### PART NO. DESCRIPTION

TCB-PLR1	Billet Aluminum Progressive Linkage Rod For Edelbrock Carbs Center Distance 6-3/8" - 6-3/4"
TCB-PLR2	Billet Aluminum Progressive Linkage Rod for Edelbrock Carbs Center Distance 8-5/8" - 9"
TCB-PLR3	Billet Aluminum Progressive Linkage Rod for Holley Carbs Center Distance 8-1/4" - 8-5/8"
XTCB-PLR1	Black Billet Aluminum Progressive Linkage Rod For Edelbrock Carburetors Center Distance 6-3/8" - 6-3/4"
XTCB-PLR2	Black Billet Aluminum Progressive Linkage Rod For Edelbrock Carburetors Center Distance 8-5/8" - 9"
XTCB-PLR3	Black Billet Aluminum Progressive Linkage Rod For Holley Carburetors Center Distance 8-1/4" - 8-5/8"

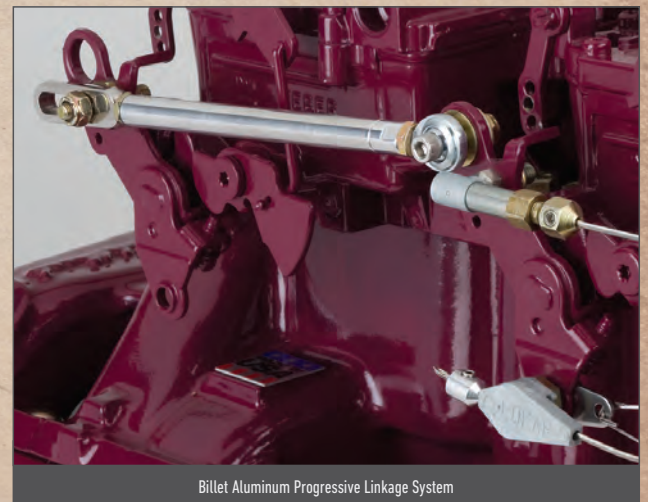

Billet Aluminum Progressive Linkage System



## BILLET DRIVE-BY-WIRE ELECTRONIC THROTTLE CONTROL PEDAL ASSEMBLY

Lokar's Billet Drive-By-Wire Electronic Throttle Control Pedal assembly is pre-programmed at the factory for specific OEM and Aftermarket EFI applications, including Crate Engines. Included with the Lokar Electronic Throttle Control is an application-specific pedal wiring harness that works in conjunction with the OEM or After market EFI wiring harness. Pedal calibration optimizes throttle response to eliminate pedal lag. The Billet Drive-By-Wire Pedal also has built in hysteresis to provide improved operator control and pedal stability over rough terrain.

The new billet design is available in bright or black anodized finish to match your application. The Electronic Throttle Control/Harness requires one of Lokar's Drive-By-Wire Pedal sets, which are offered in a variety of styles. Each item is sold separately for versatility.



**ORDERING TIP**

Does not come with pedal pad & arm; sold separately. (See Page 51)

### ELECTRONIC THROTTLE CONTROL WITH HARNESS

PART NO.	DESCRIPTION
BDBW-FORD01	2011-2012 Ford Mustang and all Coyote 5.0L crate engines
BDBW-GM01	Late 2007-2012 Silverado (except Classic), Suburban, Tahoe, Avalanche, Sierra, Yukon, Escalade, and Hummer with OEM pedal # 25832864, 15847349, or equivalent
BDBW-GM02	2006-2012 Corvette with OEM pedal # 25835421, 15864594, or equivalent
BDBW-GM03	2004-2009 Trailblazer, Ranier, Bravada, SSR, Envoy with OEM pedal # 15145758, 15187573, or equivalent
BDBW-GM04	2006-2007 Monte Carlo; 2004-2008 Grand Prix with OEM pedal # 25830024, 10345632, 15831256, 15884315, or equivalent
BDBW-GM05	2006-2007 Silverado Classic, Escalade, Avalanche, Suburban, Tahoe, Sierra, and Yukon with OEM pedal # 15107594, 15233970, or equivalent
BDBW-GM06	All GM Crate Engines; 2008-2012 Cadillac CTS & CTS-V; 2010-2012 Camaro with OEM pedal # 10379038, 10367117, 22741799, 22741800, 92199239, or equivalent
BDBW-GM07	2006-2008 GTO with OEM pedal # 92188385, or equivalent
BDBW-GM08	2007-2011 Express and Savanna van with OEM pedal # 15821777, 20827131, or equivalent
BDBW-HOLLEY01	Holley Dominator EFI with OEM pedal # 10379038
BDBW-MAST01	All MAST M90 applications with OEM pedal # 25835421
BDBW-MOPAR01	2005-2012 Charger, Magnum, 300, Ram Truck, Grand Cherokee, Durango; 2008-2012 Challenger; with all OEM pedals

**ORDERING TIP**

Add 'X' before part number when ordering black anodized finish. e.g. XBDBW-FORD-1



DBW-6001 Drive-By-Wire Billet Aluminum Spring-Loaded Throttle Pedal Ball-Milled	DBW-6004 Drive-By-Wire Billet Aluminum Spring-Loaded Throttle Pedal w/Rubber	DBW-6007 Drive-By-Wire Chrome Steel Spring-Loaded Throttle Pedal w/Rubber	DBW-6010 Drive-By-Wire XL Billet Aluminum Spring-Loaded Throttle Pedal Ball-Milled	DBW-6012 Drive-By-Wire XL Billet Aluminum Spring-Loaded Throttle Pedal w/Rubber	DBW-6016 Drive-By-Wire XL Chrome Steel Spring-Loaded Throttle Pedal w/Rubber	DBW-6070 Drive-By-Wire Chrome Steel Spoon Throttle Pedal
DBW-6103 Drive-By-Wire Mini Oval Billet Spring-Loaded Throttle Pedal w/Rubber	DBW-6104 Drive-By-Wire Oval Billet Spring-Loaded Throttle Pedal w/Rubber	DBW-6105 Drive-By-Wire XL Oval Billet Spring-Loaded Throttle Pedal w/Rubber	DBW-6151 Drive-By-Wire Lakester Steel Throttle Pedal - Chrome	DBW-6154 Drive-By-Wire Lakester Steel Throttle Pedal - Raw	XDBW-6004 Black Drive-By-Wire Billet Aluminum Spring-Loaded Throttle Pedal w/Rubber	XDBW-6007 Black Drive-By-Wire Steel Spring-Loaded Throttle Pedal w/Rubber
XDBW-6012 Black Drive-By-Wire XL Billet Aluminum Spring-Loaded Throttle Pedal w/Rubber	XDBW-6016 Black Drive-By-Wire XL Steel Spring-Loaded Throttle Pedal w/Rubber	XDBW-6070 Black Drive-By-Wire Steel Spoon Throttle Pedal	XDBW-6103 Black Drive-By-Wire Mini Oval Billet Spring-Loaded Throttle Pedal w/Rubber	XDBW-6104 Black Drive-By-Wire Oval Billet Spring-Loaded Throttle Pedal w/Rubber	XDBW-6105 Black Drive-By-Wire XL Oval Billet Spring-Loaded Throttle Pedal w/Rubber	XDBW-6151 Black Drive-By-Wire Lakester Steel Throttle Pedal - Black

## DIRECT FIT DRIVE-BY-WIRE THROTTLE PEDAL PADS

(ELECTRONIC PEDAL NOT INCLUDED)

PART NO. DESCRIPTION

BAG-6150	2005 & Later Corvette Throttle Pad w/Rubber - Brushed
BAG-6157	2005-2006 Pontiac GTO Throttle Pad w/Rubber - Brushed
BAG-6158	1997-2004 Corvette Throttle Pad w/Rubber - Brushed
XBAG-6150	2005 & Later Corvette Throttle Pad w/Rubber - Black
XBAG-6157	2005-2006 Pontiac GTO Throttle Pad w/Rubber - Black
XBAG-6158	1997-2004 Corvette Throttle Pad w/Rubber - Black
*DBW-6200	Direct Fit Throttle Pedal Pad for Cadillac CTS-V Drive-By-Wire Pedal
*XDBW-6200	Black Direct Fit Throttle Pedal Pad for Cadillac CTS-V Drive-By-Wire Pedal <i>*Designed to fit GM Part # 10379038</i>





# Throttle Assemblies & Pedal Pads

## STANDARD BILLET ALUMINUM THROTTLE ASSEMBLIES AND PEDAL PADS

Ball-milled aluminum throttle pedal has spring-loaded pad like OEM design. Removable lower arm is splined for versatility in mounting to the right or left of the mounting bracket. Lokar's exclusive upper arm is a one-piece design. Shaft and arm are one piece, requiring no pins. Matching brake pad is designed with a 1/2" - 20 thread and includes a 1/2" - 20 stud in kit. Can be mounted centered or off center. Dimmer fits both Chevy and Ford.

PART NO.	DESCRIPTION
BAG-6001	Billet Aluminum Throttle Pedal Ball-Milled - Brushed
BAG-6002	Billet Aluminum Brake Pad Ball-Milled - Brushed
BAG-6003	Billet Aluminum Dimmer Switch Cover Ball-Milled - Brushed
BAG-6004	Billet Aluminum Throttle Pedal w/Rubber - Brushed
XBAG-6004	Billet Aluminum Throttle Pedal w/Rubber - Black
BAG-6005	Billet Aluminum Brake Pad w/Rubber - Brushed
XBAG-6005	Billet Aluminum Brake Pad w/Rubber - Black
BAG-6006	Billet Aluminum Dimmer Switch Cover w/Rubber - Brushed
XBAG-6006	Billet Aluminum Dimmer Switch Cover w/Rubber - Black
GPS-6014	3/4" Billet Aluminum Throttle Pedal Spacer - Brushed
XGPS-6014	3/4" Billet Aluminum Throttle Pedal Spacer - Black



GPS-6014  
3/4" Billet Aluminum  
Throttle Pedal Spacer

BAG-6004

BAG-6005

BAG-6006



XBFR-6116 Foot Rest  
(See page 46)



XBAG-6006



XBAG-6005



XBAG-6004



ORDERING  
TIP

Designed to match foot rest part no. BFR-6115 (See Page 54)



BAG-6001

BAG-6002

BAG-6003



## XL SERIES BILLET ALUMINUM THROTTLE ASSEMBLIES AND PEDAL PADS

XL Series ball-milled billet aluminum Throttle Pedal is designed just like our standard billet aluminum throttle assemblies, but has an EXTRA LARGE pad for those seeking more comfort and safety. Throttle Pedal pad is spring-loaded like OEM design. Removable lower arm is splined for versatility in mounting to the right or left of the mounting bracket. Lokar's exclusive upper arm is a one-piece design. Shaft and arm are one piece, requiring no pins. Matching XL Series brake pad is designed with a 1/2"-20 thread and includes a 1/2"-20 stud in kit. Can be mounted centered or off center.

PART NO.	DESCRIPTION
BFG-6010	XL Series Billet Aluminum Throttle Pedal Ball-Milled - Brushed
BFG-6011	XL Series Billet Aluminum Brake Pad Ball-Milled - Brushed
BAG-6003	Billet Aluminum Dimmer Switch Cover Ball-Milled -Brushed
BFG-6012	XL Series Billet Aluminum Throttle Pedal w/Rubber - Brushed
XBFG-6012	XL Series Billet Aluminum Throttle Pedal w/Rubber - Black
BFG-6013	XL Series Billet Aluminum Brake Pad w/Rubber - Brushed
XBFG-6013	XL Series Billet Aluminum Brake Pad w/Rubber - Black
BAG-6006	Billet Aluminum Dimmer Switch Cover w/Rubber - Brushed
XBAG-6006	Billet Aluminum Dimmer Switch Cover w/Rubber - Black



### DIMENSIONAL COMPARISON



	Throttle Pedal	Brake Pad
XL Series Dimensions	2" x 5"	3-3/4" x 2-3/4"
Standard Dimensions	1-1/2" x 4"	3" x 2"



Always mount throttle pedals first before installing throttle cable to obtain proper alignment.



## Award Winning

### ELIMINATOR FLOOR MOUNT THROTTLE PEDALS

Lokar's Eliminator Floor Mount Throttle Pedal is designed with the Signature Lokar Quality you have come to expect. Pedal eliminates routing cables through firewall and comes equipped with a billet aluminum splined adjustable shaft and stainless steel "under-the-floor" cable mounting bracket. Mounts in multiple positions for floor and toe board angles. Designed with built-in pedal travel stops.



Under-the-floor cable mounting bracket  
Included with pedal

PART NO.	DESCRIPTION
----------	-------------

FMG-6097	Billet Aluminum Eliminator Floor Mount Throttle Pedal - Brushed
FMG-6098	Billet Aluminum Eliminator Floor Mount Throttle Pedal w/Rubber - Brushed
XFMG-6098	Billet Aluminum Eliminator Floor Mount Throttle Pedal w/Rubber - Black
GPS-6016	1/2" Billet Aluminum Floor Mount Throttle Pedal Spacer - Brushed
XGPS-6016	1/2" Billet Aluminum Floor Mount Throttle Pedal Spacer - Black



FMG-6098 Eliminator Floor Mount Throttle Pedal with Rubber Inserts



FMG-6097 Eliminator  
Floor Mount Throttle Pedal

XFMG-6098 Eliminator  
Floor Mount Throttle Pedal with  
Rubber Inserts - Black



Requires 36" "U-Cut-to-Fit"  
Lokar Throttle Cable for most  
applications. Order 48" cable for  
LS1, Ram Jet 350, and Vortec  
applications.



GPS-6016  
1/2" Billet Aluminum Floor Mount  
Throttle Pedal Spacer

### BILLET ALUMINUM ADJUSTABLE FOOT RESTS

#### Features

- Matches Lokar pedals
- Adjustable angles for foot comfort
- Universal mounting locations
- Available in three styles:

Oval pad with rubber inserts - brushed or black  
Rectangular pad in ball-milled billet aluminum - brushed  
Rectangular pad with rubber inserts - brushed or black

PART NO.	DESCRIPTION
----------	-------------

BFR-6114	Oval Billet Aluminum Pad w/Rubber - Brushed
XBFR-6114	Oval Billet Aluminum Pad w/Rubber - Black
BFR-6115	Rectangular Billet Aluminum Pad Ball-milled - Brushed
BFR-6116	Rectangular Billet Aluminum Pad w/Rubber - Brushed
XBFR-6116	Rectangular Billet Aluminum Pad w/Rubber - Black

#### DIMENSIONS:

Oval: 1-3/4" x 3-3/4"  
Rectangular: 1-1/2" x 4"



BFR-6116



BFR-6115



BFR-6114



XBFR-6116

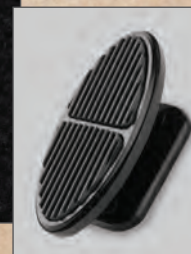

XBFR-6114



## OVAL BILLET ALUMINUM THROTTLE ASSEMBLIES & PEDAL PADS

Oval billet aluminum throttle pedals and brake pads come in three convenient sizes – Mini, Standard, and XL. The throttle pedal is spring-loaded with a removable lower arm that is splined for versatility and can be mounted to the right or left of the mounting bracket. The shaft and arm are one piece – requiring no pins. Rubber inserts provide foot traction for safety. Brake pads are designed with a 1/2"-20 thread and include a 1/2"-20 stud in the kit. Can be mounted centered or off center.

PART NO.	DESCRIPTION
BAG-6103	Mini Oval Billet Aluminum Throttle Pedal - Brushed
XBAG-6103	Mini Oval Billet Aluminum Throttle Pedal - Black
BAG-6104	Standard Oval Billet Aluminum Throttle Pedal - Brushed
XBAG-6104	Standard Oval Billet Aluminum Throttle Pedal - Black
BAG-6105	XL Oval Billet Aluminum Throttle Pedal - Brushed
XBAG-6105	XL Oval Billet Aluminum Throttle Pedal - Black
BAG-6106	Mini Oval Billet Aluminum Brake Pad - Brushed
XBAG-6106	Mini Oval Billet Aluminum Brake Pad - Black
BAG-6107	Standard Oval Billet Aluminum Brake Pad - Brushed
XBAG-6107	Standard Oval Billet Aluminum Brake Pad - Black
BAG-6108	XL Oval Billet Aluminum Brake Pad - Brushed
XBAG-6108	XL Oval Billet Aluminum Brake Pad - Black
BAG-6109	Oval Billet Aluminum Dimmer Switch Cover - Brushed
XBAG-6109	Oval Billet Aluminum Dimmer Switch Cover - Black



Brake Pad and Dimmer Cover can be mounted vertically or horizontally.

### STANDARD



BAG-6109



BAG-6107



BAG-6104

#### OVAL THROTTLE PEDAL AND BRAKE PAD DIMENSIONAL COMPARISON

	Throttle Pedal	Brake Pad
Mini Oval	1-3/8" x 2-3/8"	3-7/16" x 1-5/8"
Standard Oval	1-3/4" x 3-3/4"	3-3/4" x 1-3/4"
XL Oval	2-3/8" x 5"	5" x 2-3/8"



**ORDERING TIP** { Designed to compliment Foot Rest brushed part no. BFR-6114 and black part no. XBR-6114 (See Page 54).

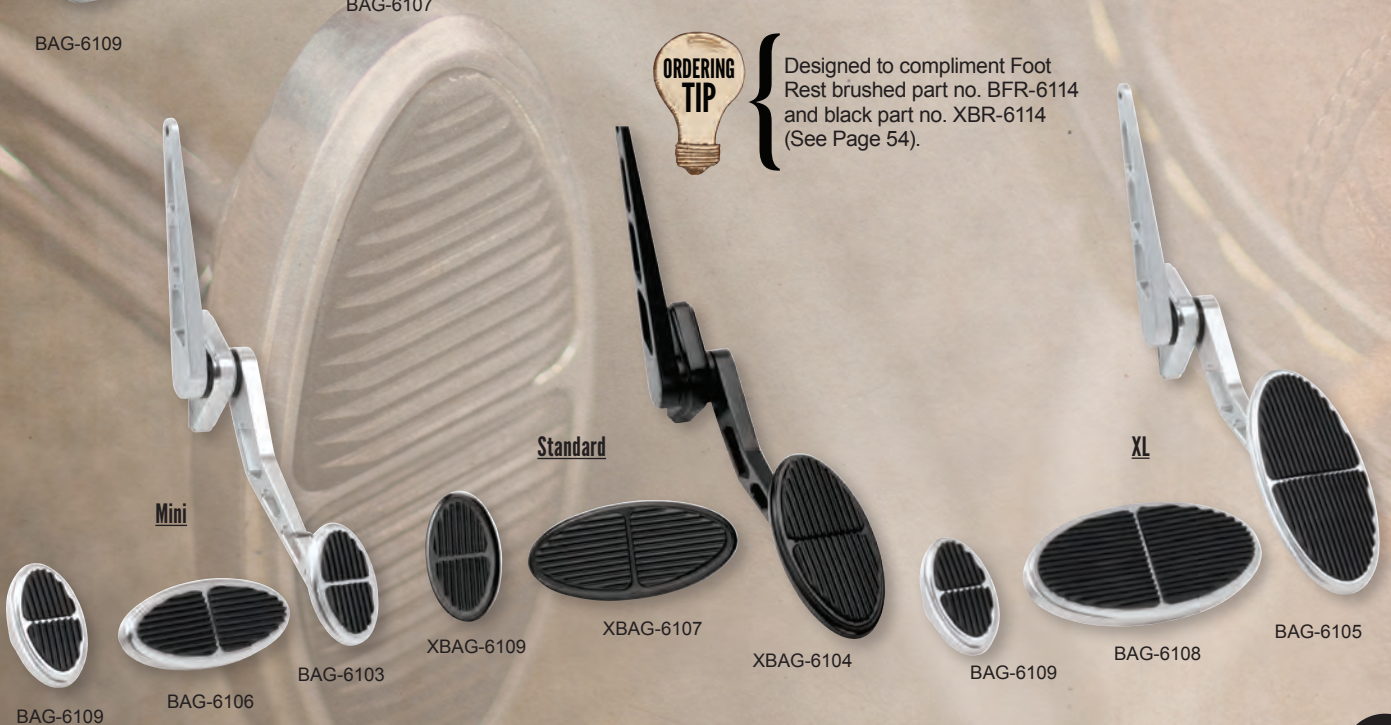

Mini

Standard

XL

BAG-6109

BAG-6106

BAG-6103

XBAG-6109

XBAG-6107

XBAG-6104

BAG-6109

BAG-6108

BAG-6105



## COMPETITOR SERIES THROTTLE ASSEMBLIES

Lokar's Competitor Series Throttle Assemblies are designed with a unique internal spanner nut ensuring perfect pedal tension. This pedal is in a class of its own. By adding this built in tensioning feature, we have eliminated the possibility of excess 'slop' in the throttle pedal.

Another milestone of the Competitor Series Throttle Pedal is its incredibly sturdy mounting base. The design of this pedal has enabled us to provide over an inch and a quarter wide mounting base yet maintain a narrow and sleek appearance. If that weren't enough, the mounting base is available in either a centered or an offset version which will raise or lower the center of the throttle assembly an entire inch. This feature is incredibly accommodating when installing the pedal in a vehicle which already has the throttle cable installed.

We have also built the Competitor Series Throttle Assemblies with our exclusive large diameter  $\frac{3}{4}$ " x 48 tooth fine-spline steel insert to provide ultimate strength and durability. This also allows for infinitely adjustable arms which can also be swapped for right and left adjustment of the throttle pad.

All of these features coupled with a spring-loaded throttle pad, Delrin® bushings, and superior design have made the Competitor Series Throttle Pedal the finest and most versatile throttle pedal available.

Centered  
Mounting



Vertical  
Offset Mounting

XBAG-6148

XBAG-6149

BAG-6148

PART NO.	DESCRIPTION
BAG-6148	Billet Aluminum Competitor Throttle Pedal Assembly with Rubber - Centered Mounting - Brushed
XBAG-6148	Billet Aluminum Competitor Throttle Pedal Assembly with Rubber - Centered Mounting - Black
BAG-6149	Billet Aluminum Competitor Throttle Pedal Assembly with Rubber - Vertical Offset Mounting - Brushed
XBAG-6149	Billet Aluminum Competitor Throttle Pedal Assembly w/Rubber - Vertical Offset Mounting - Black

## LAKESTER THROTTLE ASSEMBLIES AND PEDAL PADS

Lakester™ hot rod pedal styling is a continuation of the many nostalgic products we offer at Lokar. The pedals have the same quality you have come to expect from its sister steel spoon throttle pedal and round brake/clutch pad. The removable lower arm is splined for versatility in mounting to the right or left of the mounting bracket. Lakester pedals feature curved pads and arms and are available in chrome, black and raw giving your vehicle an all new look. The throttle pedal is designed using Delrin® bushings for smooth operation when throttling up or down during daily use.

PART NO.	DESCRIPTION
BAG-6151	Lakester Steel Throttle Pedal - Chrome
XBAG-6151	Lakester Steel Throttle Pedal - Black
BAG-6154	Lakester Steel Throttle Pedal - Raw
BAG-6152	Lakester Steel Brake/Clutch - Chrome(each)
XBAG-6152	Lakester Steel Brake/Clutch - Black (each)
BAG-6155	Lakester Steel Brake/Clutch - Raw (each)
BAG-6153	Lakester Steel Automatic Brake - Chrome
XBAG-6153	Lakester Steel Automatic Brake - Black
BAG-6156	Lakester Steel Automatic Brake - Raw
BAG-6170	Lakester Steel Dimmer Switch Cover - Chrome
XBAG-6170	Lakester Steel Dimmer Switch Cover - Black
BAG-6171	Lakester Steel Dimmer Switch Cover - Raw



Raw

Chrome

Black



Lakester Throttle Assemblies match Lakester Door Handles and Window Cranks on Page 27.



## STEEL THROTTLE ASSEMBLIES AND PEDAL PADS STANDARD & XL SERIES

Lokar's Steel Throttle Pedals are the first spring-loaded steel pedal in the industry and are designed after OEM pedals. Removable lower arm is splined for versatility in mounting to the right or left of the mounting bracket. Lokar offers these steel assemblies in both our standard pad size and our larger, XL pad. The XL pad is EXTRA LARGE for those seeking more substance under foot. Matching Steel Brake Pads mount with a 1/2"-20 stud built into the back of the pad. Matching Dimmer Switch Cover fits both Chevy and Ford. Available in chrome or black finish.

PART NO.	DESCRIPTION
SG-6007	Steel Throttle Pedal w/Rubber – Chrome
XSG-6007	Steel Throttle Pedal w/Rubber – Black Powder Coated
SG-6008	Steel Brake Pad w/Rubber – Chrome
XSG-6008	Steel Brake Pad w/Rubber – Black Powder Coated
SG-6009	Steel Dimmer Switch Cover (Fits Chevy and Ford) - Chrome
XSG-6009	Steel Dimmer Switch Cover (Fits Chevy and Ford) - Black Powder Coated
SG-6016	XL Steel Throttle Pedal w/Rubber – Chrome
XSG-6016	XL Steel Throttle Pedal w/Rubber – Black Powder Coated
SG-6017	XL Steel Brake Pad w/Rubber – Chrome
XSG-6017	XL Steel Brake Pad w/Rubber – Black Powder Coated
GPS-6015	1/2" Throttle Pedal Spacer for Steel Pedals – Brushed
XGPS-6015	1/2" Throttle Pedal Spacer for Steel Pedals – Black Powder Coated

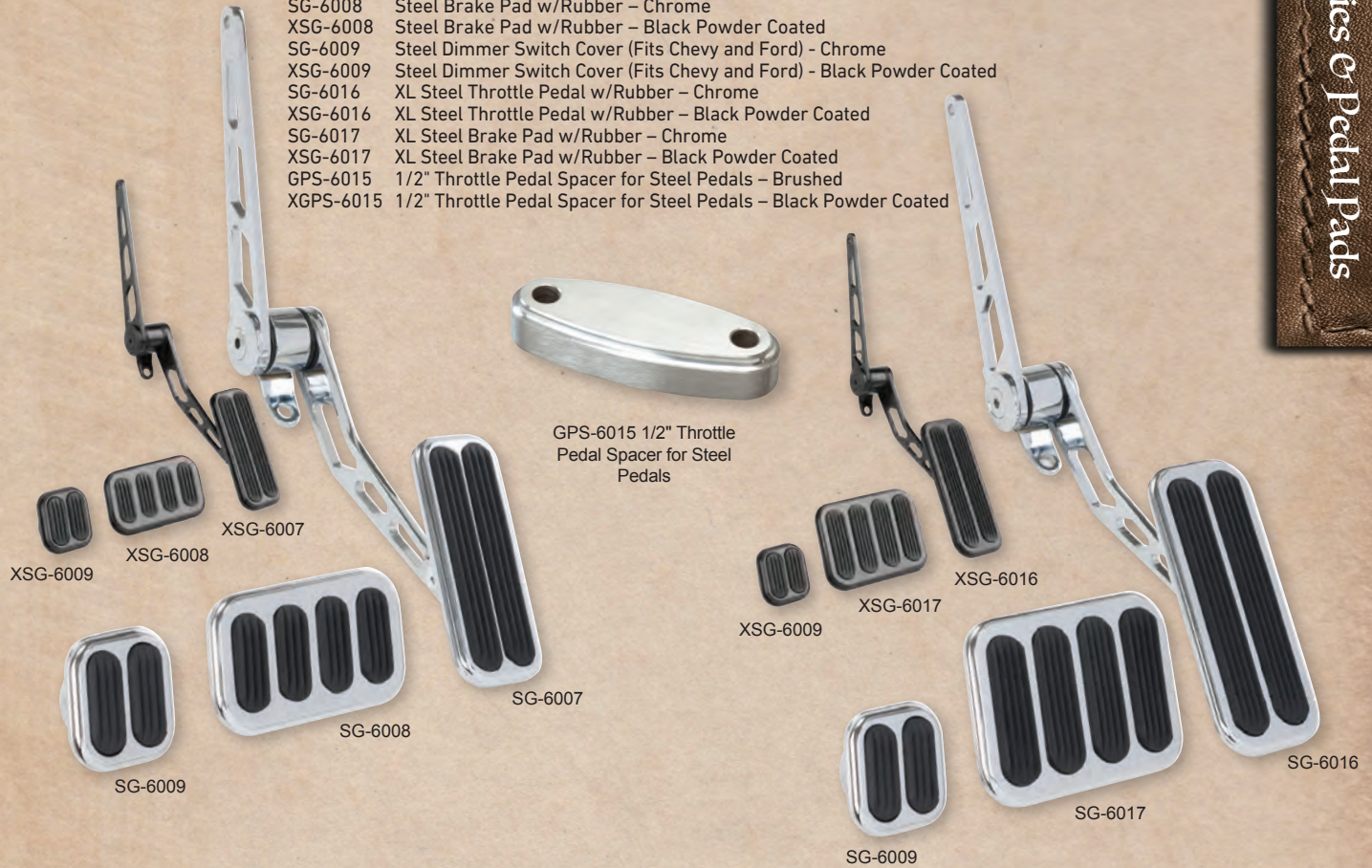

## STEEL SPOON THROTTLE ASSEMBLIES AND PEDAL PADS

Nostalgic hot rod style is exhibited with Lokar's Spoon Throttle Pedal. The pedal is designed with the same quality as demonstrated in other Lokar Throttle assemblies. The removable lower arm is splined for versatility in mounting to the right or left of the mounting bracket. Steel round brake/clutch pads and dimmers are equipped with rubber inserts which completes the ensemble. The Spoon Pedal and matching Brake/Clutch Pad and Dimmer are available in chrome or black finish.

PART NO.	DESCRIPTION
SPO-6070	Steel Spoon Throttle Pedal – Chrome
XSP0-6070	Steel Spoon Throttle Pedal – Black Powder Coated
SPO-6071	Round Steel Brake/Clutch Pad w/Rubber – Chrome
XSP0-6071	Round Steel Brake/Clutch Pad w/Rubber – Black Powder Coated
SPO-6072	Round Steel Dimmer Switch Cover w/Rubber – Chrome
XSP0-6072	Round Steel Dimmer Switch Cover w/Rubber – Black Powder Coated







# EDGE™ EDITION PEDAL PADS



The Goolsby Edge Edition Billet Aluminum Throttle Pedal Assembly and Pedal Pads bring a new rugged muscle car feel to your ride. Throttle assembly has customizable removable inserts and utilizes the Competitor Series base.

PART NO.	DESCRIPTION
BAG-6194	Goolsby Edge Edition Billet Aluminum Brake And Clutch Pad - Pair
BAG-6195	Goolsby Edge Edition Billet Aluminum Throttle Pedal Pad
BAG-6196	Goolsby Edge Edition Billet Aluminum Throttle Pedal Assembly
BAG-6197	Goolsby Edge Edition Billet Aluminum Automatic Brake Pad



## GOOLSBY EDITION BY LOKAR THROTTLE PEDAL ASSEMBLY

The Goolsby Edition by Lokar Throttle Pedal Assembly features alloy steel construction and is available in chrome and raw. The removable lower arm is a splined arm for maximum versatility. The Brake and Clutch Pedal Pads feature billet aluminum constructions. The mounting stud is 1/2-20 to be compatible with most aftermarket brake and clutch arms. They are also available for use with the Lokar Brake and Clutch arms.

PART NO.	DESCRIPTION
BAG-6188	Goolsby Edition Steel Throttle Pedal with Polished Round Pad - Chrome
XBAG-6188	Goolsby Edition Steel Throttle Pedal with Polished Round Pad - Black
BAG-6189	Goolsby Edition Steel Throttle Pedal with Polished Round Pad - Raw
BAG-6190	Goolsby Edition Round Brake/Clutch Pad - Polished
XBAG-6190	Goolsby Edition Round Brake/Clutch Pad - Black





# Direct Fit Brake & Clutch Arms

Direct Fit Brake & Clutch Arms



**ORDERING TIP** } Compliment your design by pairing these Goolsby Edition by Lokar Throttle Pedal Assemblies and Brake and Clutch Arms with other product on pages 15 and 23.

## GOOLSBY EDITION BY LOKAR BRAKE & CLUTCH ARMS

The Goolsby Edition by Lokar, Brake and Clutch Arms are made of an alloy steel construction. They are available in your choice of chrome or raw finish. The arms work with Kugel Komponenten 90° and 180° pedal aftermarket under-the-dash brake and clutch systems. The Goolsby Edition pedal pads are included. The design complements other products in the Goolsby Edition series.

PART NO.	DESCRIPTION
BCA-9515	Goolsby Edition 90 Degree Direct Fit Brake & Clutch Arm with Round Pad - Chrome
XBCA-9515	Goolsby Edition 90 Degree Direct Fit Brake & Clutch Arm with Round Pad - Black
BCA-9516	Goolsby Edition 90 Degree Direct Fit Brake & Clutch Arm with Round Pad - Raw
BCA-9517	Goolsby Edition 180 Degree Direct Fit Brake & Clutch Arm with Round Pad - Chrome
XBCA-9517	Goolsby Edition 180 Degree Direct Fit Brake & Clutch Arm with Round Pad - Black
BCA-9518	Goolsby Edition 180 Degree Direct Fit Brake & Clutch Arm with Round Pad - Raw



**ORDERING TIP** } See Page 61 For Tri-Five brake and clutch arms.  
See page 65 for Chevy / GMC C-10 brake and clutch arms.

## BILLET ALUMINUM DIRECT FIT BRAKE AND CLUTCH PEDAL ARMS

### FEATURES

- Direct replacement of the original brake & clutch pedal arms
- Billet aluminum construction
- Windowed arms complement other Lokar products
- Bronze pivot bushing for increased durability
- Unique styling
- Brushed or black finish
- Available for Kugel Komponenten 90° & 180° pedal assemblies.



XBCA-9502



BCA-9501

PART NO.	DESCRIPTION
BCA-9500	90° Billet Aluminum Direct Fit Automatic Brake Pedal Arm with XL Oval Pad
XBCA-9500	90° Billet Alum Direct Fit Automatic Brake Pedal Arm with XL Oval Pad - Black
BCA-9501	90° Billet Aluminum Direct Fit Automatic Brake Pedal Arm with XL Pad
XBCA-9501	90° Billet Aluminum Direct Fit Automatic Brake Pedal Arm with XL Pad - Black
BCA-9502	90° Billet Alum Direct Fit Brake & Clutch Pedal Arm with Standard Oval Pad
XBCA-9502	90° Billet Alum Direct Fit Brake & Clutch Pedal Arm with Standard Oval Pad - Black
BCA-9503	90° Billet Aluminum Direct Fit Brake & Clutch Pedal Arm with Standard Pad
XBCA-9503	90° Billet Alum Direct Fit Brake & Clutch Pedal Arm with Standard Pad - Black
BCA-9504	180° Billet Aluminum Direct Fit Automatic Brake Pedal Arm with XL Oval Pad
XBCA-9504	180° Billet Alum Direct Fit Automatic Brake Pedal Arm with XL Oval Pad - Black
BCA-9505	180° Billet Aluminum Direct Fit Automatic Brake Pedal Arm with XL Pad
XBCA-9505	180° Billet Alum Direct Fit Automatic Brake Pedal Arm with XL Pad - Black
BCA-9506	180° Billet Alum Direct Fit Brake & Clutch Pedal Arm with Standard Oval Pad
XBCA-9506	180° Billet Alum Direct Fit Brake & Clutch Pedal Arm w/Standard Oval Pad - Black
BCA-9507	180° Billet Alum Direct Fit Brake & Clutch Pedal Arm with Standard Pad
XBCA-9507	180° Billet Alum Direct Fit Brake & Clutch Pedal Arm with Standard Pad - Black



BCA-9502



# Direct Fit Throttle Assemblies & Pedal Pads

## 1955 - 1957 CHEVY THROTTLE ASSEMBLIES

The Lokar 1955-1957 Chevy billet aluminum Throttle Assembly is designed to convert original rod linkage to Lokar's modern throttle cable system. It is designed to mount in original firewall location with offset bezel washers to align cable through firewall. The arms are splined for fine adjustment and can be switched for right and left adjustment of the throttle pad. The Throttle Pad is spring-loaded like the OEM design and measures 2" x 5".



BAG-6074 Throttle Pedal Shown and BAG-6076 Brake/Clutch Pad shown



PART NO.	DESCRIPTION
BAG-6073	1955-1957 Chevy Billet Aluminum Throttle Pedal Assembly - Brushed
BAG-6074	1955-1957 Chevy Billet Aluminum Throttle Pedal Assembly w/Rubber - Brushed
XBAG-6074	1955-1957 Chevy Billet Aluminum Throttle Pedal Assembly w/Rubber - Black
BAG-6112	1955-1957 Chevy Billet Aluminum Throttle Pedal Assembly (1" longer upper arm for Big Block) - Brushed
BAG-6113	1955-1957 Chevy Billet Aluminum Throttle Pedal Assembly w/Rubber (1" longer upper arm for Big Block) - Brushed
XBAG-6113	1955-1957 Chevy Billet Aluminum Throttle Pedal Assembly w/Rubber (1" longer upper arm for Big Block) - Black



XBAG-6078

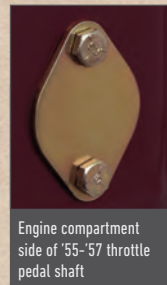

Engine compartment side of '55-'57 throttle pedal shaft



'55-'57 throttle pedal shaft

XBAG-6074

## 1955 - 1957 CHEVY TRADITIONAL FLAT BRAKE PADS, CLUTCH PADS & POWER BRAKE PADS

Brake and Clutch Pads are designed to match the Throttle Pedal assemblies. With Lokar's exclusive mounting design, no drilling is needed to mount pads, which allows for easy installation.

PART NO.	DESCRIPTION
BAG-6075	1955-1957 Chevy Billet Aluminum Brake/Clutch Pad - Brushed
BAG-6076	1955-1957 Chevy Billet Aluminum Brake/Clutch Pad w/Rubber - Brushed
XBAG-6076	1955-1957 Chevy Billet Aluminum Brake/Clutch Pad w/Rubber - Black
BAG-6077	1955-1957 Chevy Billet Aluminum Automatic Power Brake Pad - Brushed
BAG-6078	1955-1957 Chevy Billet Aluminum Automatic Power Brake Pad w/Rubber - Brushed
XBAG-6078	1955-1957 Chevy Billet Aluminum Automatic Power Brake Pad w/Rubber - Black
BAG-6079	1955-1957 Chevy XL Billet Aluminum Automatic Non-Power Brake Pad - Brushed
BAG-6080	1955-1957 Chevy XL Billet Aluminum Automatic Non-Power Brake Pad w/Rubber - Brushed
XBAG-6080	1955-1957 Chevy XL Billet Aluminum Automatic Non-Power Brake Pad w/Rubber - Black



BAG-6078 Power Brake Mount



BAG-6079 XL Non-Power Brake Mount



### Brake and Clutch Pads

(Outside measurement of 3-7/8" x 2-5/8" fits 3-1/4" x 1-5/8" original steel brake pedal)

### Power Brake Pads

(Outside measurement of 6" x 2-3/4" fits 4-3/4" x 2-3/8" original steel brake pedal)

### XL Non-Power Brake Pads

(Outside measurement of 6" x 2-3/4" and fits 3-1/4" x 1-5/8" original steel brake pedal)



## 1955 - 1957 CHEVY CURVED BRAKE PADS, CLUTCH PADS & POWER BRAKE PADS

For a compact and clean look, Lokar has put a modern bend on classic brake pedal pads. Our Curved Brake/Clutch Pedal Pads add style and function to your classic car. Designed with hidden screws, these pads are curved and pocketed to match and bolt directly to the factory steel brake pedal. Each brake pedal pad has been fashioned after its corresponding factory rubber pad and is available in brushed or black finish.

PART NO.	DESCRIPTION
BAG-6137	1955-1957 Chevy Billet Aluminum Curved Power Brake Pad w/Rubber - Brushed
XBAG-6137	1955-1957 Chevy Billet Aluminum Curved Power Brake Pad w/Rubber - Black
BAG-6138	1955-1957 Chevy Billet Aluminum Curved XL Non-Power Brake Pad w/Rubber - Brushed
XBAG-6138	1955-1957 Chevy Billet Aluminum Curved XL Non-Power Brake Pad w/Rubber - Black
BAG-6139	1955-1957 Chevy Billet Aluminum Curved Brake/Clutch Pad Manual w/Rubber (Pair) - Brushed
XBAG-6139	1955-1957 Chevy Billet Aluminum Curved Brake/Clutch Pad Manual w/Rubber (Pair) - Black



BAG-6137 and BAG-6138



Curved Power Brake Mount BAG-6137



XL Curved Non-Power Brake Mount BAG-6138



BAG-6139 (Pair)



BAG-6074 (Recommended Throttle)



XBAG-6137 and XBA6-6138



XBAG-6139 (Pair)



XBAG-6074 (Recommended Throttle)



BAG-6140 (Pair)

## 1955 - 1957 CHEVY BRAKE AND CLUTCH ARMS WITH PADS

BCA-9511	55-57 Billet Aluminum Curved Chevy Direct Fit Automatic Brake Pedal Arm with Standard Pad
XBCA-9511	55-57 Billet Aluminum Curved Chevy Direct Fit Automatic Brake Pedal Arm with Standard Pad - Black
BCA-9512	55-57 Billet Aluminum Curved Chevy Direct Fit Automatic Brake Pedal Arm with Power Brake Pad
XBCA-9512	55-57 Billet Aluminum Curved Chevy Direct Fit Automatic Brake Pedal Arm with Power Brake Pad - Black
BCA-9513	55-57 Billet Aluminum Curved Chevy Direct Fit Brake & Clutch Pedal Arm with Standard Pad
XBCA-9513	55-57 Billet Aluminum Curved Chevy Direct Fit Brake & Clutch Pedal Arm with Standard Pad - Black



BCA-9513



## 1967 - 1969 CAMARO/FIREBIRD THROTTLE ASSEMBLIES

Direct replacement Throttle Pedal Assemblies for 1967-1969 Camaro/ Firebird with ball-milled or with rubber insert pads eliminate the factory rod linkage, are designed to mount in the original firewall location and utilize a modern Lokar Throttle Cable system. The arms are splined for fine adjustment and can be switched for right and left adjustment of the throttle pad, which is spring-loaded and measures 2" x 5". Available in brushed or black finish.

PART NO.	DESCRIPTION
BAG-6095	1967-1969 Camaro/Firebird Billet Aluminum Throttle Pedal Assembly – Brushed
BAG-6096	1967-1969 Camaro/Firebird Billet Aluminum Throttle Pedal Assembly w/ Rubber – Brushed
XBAG-6096	1967-1969 Camaro/Firebird Billet Aluminum Throttle Pedal Assembly w/ Rubber – Black



Engine compartment side of Camaro/ Firebird throttle pedal shaft

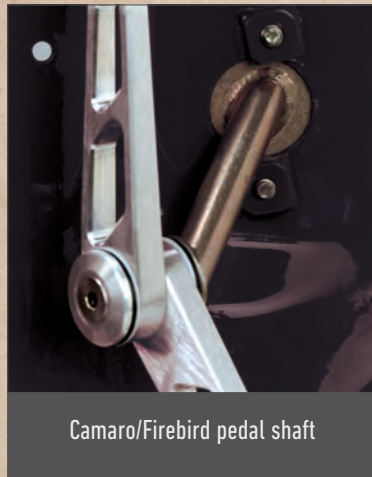

Camaro/Firebird pedal shaft



BAG-6096

XBAG-6096

## 1967 - 1969 CURVED CAMARO/FIREBIRD BRAKE/CLUTCH PEDAL PADS

For a compact and clean look, Lokar has put a modern bend on classic brake/clutch pedal pads. Our Curved Brake/Clutch Pedal Pads add style and function to your classic car. Designed with hidden screws, these pads are curved to match and bolt directly to the factory steel brake pedal. Each brake pedal pad has been fashioned after its corresponding factory rubber pad and is available in brushed or black finish.

PART NO.	DESCRIPTION
BAG-6133	1967-1969 Camaro/Firebird Billet Aluminum Curved Brake/Clutch Pad w/Rubber (Pair) – Brushed
XBAG-6133	1967-1969 Camaro/Firebird Billet Aluminum Curved Brake/Clutch Pad w/Rubber (Pair) – Black
BAG-6134	1967-1969 Camaro/Firebird Billet Aluminum Curved Automatic Brake Pad w/Rubber – Brushed
XBAG-6134	1967-1969 Camaro/Firebird Billet Aluminum Curved Automatic Brake Pad w/Rubber – Black
BAG-6159	1969-1981 Camaro/Firebird Billet Aluminum Curved E-Brake Pad w/Rubber
XBAG-6159	1969-1981 Camaro/Firebird Billet Aluminum Curved E-Brake Pad w/Rubber – Black
BAG-6161	1967-1968 Camaro/Firebird Billet Aluminum Curved E-Brake Pad w/Rubber
XBAG-6161	1967-1968 Camaro/Firebird Billet Aluminum Curved E-Brake Pad w/Rubber – Black



BAG-6134



XBAG-6134



BAG-6133 (Pair)



XBAG-6133 (Pair)



**ORDERING TIP**

For a truly complete look, combine these brake pedal pads with one of our direct fit throttle assemblies.



## 1967 - 1969 CAMARO/FIREBIRD TRADITIONAL FLAT BRAKE/CLUTCH PADS

Billet aluminum Brake and Clutch Pads are designed to match the Lokar Throttle Pedal Assemblies and are machined to fit over the stock steel pads with Lokar's exclusive mounting design. No drilling is needed and installation is simple. Traditional pads are available with ball-mill or rubber inserts and a brushed or black finish.

PART NO.	DESCRIPTION
BAG-6093	1967-1969 Camaro/Firebird Billet Aluminum Automatic Brake Pad - Brushed
BAG-6094	1967-1969 Camaro/Firebird Billet Aluminum Automatic Brake Pad with Rubber - Brushed
XBAG-6094	1967-1969 Camaro/Firebird Billet Aluminum Automatic Brake Pad with Rubber - Black
BAG-6100	1967-1968 Camaro/Firebird Billet Aluminum E-Brake Pad - Brushed
BAG-6099	1967-1968 Camaro/Firebird Billet Aluminum E-Brake Pad w/Rubber - Brushed
XBAG-6099	1967-1968 Camaro/Firebird Billet Aluminum E-Brake Pad w/Rubber - Black
BAG-6101	1967-1969 Camaro/Firebird Billet Aluminum Brake/Clutch Pad - Brushed
BAG-6102	1967-1969 Camaro/Firebird Billet Aluminum Brake/Clutch Pad w/ Rubber Brushed
XBAG-6102	1967-1969 Camaro/Firebird Billet Aluminum Brake/Clutch Pad w/ Rubber Black



## 1967 - 1969 CAMARO/FIREBIRD THROTTLE PADS

If your set up requires that you retain the factory throttle linkage, but you still want an updated look inside the car, these Throttle Pads will do the trick. Throttle pad replaces the factory pad and mounts onto the factory arm and spring. Available with ball-mill or rubber inserts and a brushed or black finish.

PART NO.	DESCRIPTION
BAG-6091	1967-1969 Camaro/Firebird Billet Aluminum Throttle Pad - Brushed
BAG-6092	1967-1969 Camaro/Firebird Billet Aluminum Throttle Pad w/Rubber - Brushed
XBAG-6092	1967-1969 Camaro/Firebird Billet Aluminum Throttle Pad w/Rubber - Black

## 1964 - 1967 CHEVELLE THROTTLE PEDAL ASSEMBLIES AND PEDAL PADS

Direct replacement Throttle Pedal Assemblies for 1964 - 1967 Chevelle with ball-milled pad or with rubber inserts eliminate the factory rod linkage, are designed to mount in the original firewall location and utilize a modern Lokar Throttle Cable system. The arms are splined for fine adjustment and can be switched for right and left adjustment of the throttle pad, which is spring-loaded and measures 2" x 5". Available in brushed or black finish.

For a compact and clean look, Lokar has put a modern bend on classic brake/clutch pedal pads. Our Curved Brake/Clutch Pedal Pads add style and function to your classic car. Designed with hidden screws, these pads are curved to match and bolt directly to the factory steel brake/clutch pedal. Each brake/clutch pedal pad has been fashioned after its corresponding factory rubber pad and is available in brushed or black finish.



PART NO.	DESCRIPTION
BAG-6128	1964-1967 Chevelle Billet Aluminum Throttle Pedal Assembly - Brushed
BAG-6129	1964-1967 Chevelle Billet Aluminum Throttle Pedal Assembly w/Rubber - Brushed
XBAG-6129	1964-1967 Chevelle Billet Aluminum Throttle Pedal Assembly w/Rubber - Black
BAG-6132	1964-1972 Chevelle Billet Aluminum Curved Brake/Clutch Pad w/Rubber (Pair) Brushed
XBAG-6132	1964-1972 Chevelle Billet Aluminum Curved Brake/Clutch Pad w/Rubber (Pair) - Black
BAG-6135	1964-1972 Chevelle Billet Aluminum Curved Automatic Brake Pad w/Rubber - Brushed
XBAG-6135	1964-1972 Chevelle Billet Aluminum Curved Automatic Brake Pad w/Rubber - Black
BAG-6163	1964-1975 Chevelle Billet Aluminum Curved E-Brake Pad w/Rubber
XBAG-6163	1964-1975 Chevelle Billet Aluminum Curved E-Brake Pad w/Rubber - Black



## CHEVY/GMC C-10 TRUCK THROTTLE PEDAL ASSEMBLIES AND CURVED PADS

PART NO.	DESCRIPTION
BAG-6164	1967-1970 Chevrolet/GMC C-10 Billet Alum. Throttle Pedal Assembly w/Rubber
BAG-6165	1971-1972 Chevrolet/GMC C-10 Billet Alum. Throttle Pedal Assembly w/ Rubber
BAG-6166	1967-1972 Chevrolet/GMC Billet Alum. Curved Automatic Brake Pad w/Rubber
BAG-6167	1967-1972 Chevrolet/GMC Billet Alum. Curved Automatic Brake Pad w/Rubber (Long)
BAG-6168	1967-1972 Chevrolet/GMC Billet Alum. Curved Manual Brake/Clutch Pad w/Rubber (Pair)
BAG-6169	1967-1972 Chevrolet/GMC Billet Aluminum Curved E-Brake Pad w/Rubber
BAG-6177	1971-1972 Chevrolet/GMC C-10 Throttle Pedal Pad w/Rubber
BAG-6191	1960-1966 Chevrolet/GMC C-10 Billet Aluminum Curved Automatic Brake Pad w/Rubber
BAG-6192	1960-1966 Chevrolet/GMC C-10 Billet Aluminum Curved Manual Brake/Clutch Pad w/Rubber (Pair)
BAG-6193	1960-1966 Chevrolet/GMC C-10 Billet Aluminum Curved E-Brake Pad w/Rubber
XBAG-6164	1967-1970 Chevrolet/GMC C-10 Billet Alum. Throttle Pedal Assembly w/Rubber - Black
XBAG-6165	1971-1972 Chevrolet/GMC C-10 Billet Alum. Throttle Pedal Assembly w/Rubber - Black
XBAG-6166	1967-1972 Chevrolet/GMC Billet Alum. Curved Auto Brake Pad w/Rubber - Black
XBAG-6167	1967-1972 Chevrolet/GMC Billet Alum. Curved Auto Brake Pad w/Rubber (Long) - Black
XBAG-6168	1967-1972 Chevrolet/GMC Billet Alum. Curved Manual Brake/Clutch Pad w/Rubber (Pair) - Black
XBAG-6169	1967-1972 Chevrolet/GMC Billet Aluminum Curved E-Brake Pad w/Rubber - Black
XBAG-6177	1971-1972 Chevrolet GMC C-10 Throttle Pedal Pad w/Rubber - Black
XBAG-6191	1960-1966 Chevrolet/GMC C-10 Billet Aluminum Curved Automatic Brake Pad w/Rubber - Black
XBAG-6192	1960-1966 Chevrolet/GMC C-10 Billet Aluminum Curved Manual Brake/Clutch Pad w/Rubber (Pair) - Black
XBAG-6193	1960-1966 Chevrolet/GMC C-10 Billet Aluminum Curved E-Brake Pad w/Rubber - Black

### THROTTLE PEDALS FEATURE:

- Direct replacement (mounts into the factory location)
  - Billet aluminum construction
  - Adjustable upper and lower arms
  - 48 tooth fine spline
  - Delrin® bushings for smooth operation
  - Compatible with Lokar cables
  - Brushed or black finish
- \*Replaces factory rod linkage with cable linkage*

### CURVED PEDAL PADS FEATURE:

- Direct replacement
- Curved to match and bolt directly onto factory steel brake /clutch pedal arms
- Billet aluminum construction
- Hidden screws
- Rubber inserts for added traction
- Brushed or black finish







### 67-72 CHEVY/GMC C-10 DIRECT FIT BRAKE AND CLUTCH ARMS WITH PADS

- BCA-9508 67-72 Billet Aluminum Curved Chevy/GMC C-10 Direct Fit Automatic Brake Pedal Arm with Standard Pad
- XBCA-9508 67-72 Billet Aluminum Curved Chevy/GMC C-10 Direct Fit Automatic Brake Pedal Arm w/Standard Pad - Black
- BCA-9509 67-72 Billet Aluminum Curved Chevy/GMC C-10 Direct Fit Automatic Brake Pedal Arm with Long Pad
- XBCA-9509 67-72 Billet Aluminum Curved Chevy/GMC C-10 Direct Fit Automatic Brake Pedal Arm with Long Pad - Black
- BCA-9510 67-72 Billet Aluminum Curved Chevy/GMC C-10 Direct Fit Brake & Clutch Pedal Arm with Standard Pad
- XBCA-9510 67-72 Billet Aluminum Curved Chevy/GMC C-10 Direct Fit Brake & Clutch Pedal Arm with Standard Pad - Black



XBCA-9510

### LATE CHEVY TRUCK BILLET ALUMINUM THROTTLE PAD

#### Features

- Mounts onto factory arm and spring for easy installation
- Available in brushed or black finish

#### PART NO. DESCRIPTION

- BAG-6081 1973 - 1998 Chevy Truck Billet Aluminum Throttle Pad - Brushed
- BAG-6085 1973 - 1998 Chevy Truck Billet Aluminum Throttle Pad w/Rubber - Brushed
- XBAG-6085 1973 - 1998 Chevy Truck Billet Aluminum Throttle Pad w/Rubber - Black



BAG-6088



BAG-6086  
BAG-6087



BAG-6085

### LATE CHEVY TRUCK BILLET ALUMINUM BRAKE PAD

#### Features

- Billet Aluminum Brake Pad replaces factory rubber pad
- Quick and Easy Installation
- No drilling required
- No alignment problems
- Hardware included
- Available in brushed or black finish

#### PART NO. DESCRIPTION

- BAG-6082 1973 - 1975 Chevy Truck Billet Aluminum Automatic Brake Pad - Brushed
- BAG-6086 1973 - 1975 Chevy Truck Billet Aluminum Automatic Brake w/Rubber - Brushed
- XBAG-6086 1973 - 1975 Chevy Truck Billet Aluminum Automatic Brake Pad w/Rubber - Black
- BAG-6083 1976 - 2003 Chevy Truck Billet Aluminum Automatic Brake Pad - Brushed
- BAG-6087 1976 - 2003 Chevy Truck Billet Aluminum Automatic Brake Pad w/Rubber - Brushed
- XBAG-6087 1976 - 2003 Chevy Truck Billet Aluminum Automatic Brake Pad w/Rubber - Black
- BAG-6144 1976 - 2003 Chevy Truck Billet Aluminum Curved Automatic Brake Pad w/Rubber - Brushed
- XBAG-6144 1976 - 2003 Chevy Truck Billet Aluminum Curved Automatic Brake Pad w/Rubber - Black



BAG-6084



BAG-6082  
BAG-6083



BAG-6081

### LATE CHEVY TRUCK BILLET ALUMINUM BRAKE & CLUTCH PADS

#### PART NO. DESCRIPTION

- BAG-6089 1988 - 1998 Chevy Truck Billet Aluminum Late Manual Brake/Clutch Pad - Brushed
- BAG-6090 1988 - 1998 Chevy Truck Billet Aluminum Late Manual Brake/Clutch Pad w/Rubber - Brushed
- XBAG-6090 1988 - 1998 Chevy Truck Billet Aluminum Late Manual Brake/Clutch Pad w/Rubber - Black



XBAG-6088



XBAG-6086  
XBAG-6087



XBAG-6085

### LATE CHEVY TRUCK BILLET ALUMINUM EMERGENCY BRAKE PEDAL PADS

#### Features

- Replaces factory rubber pad
- Quick and Easy Installation
- No drilling required
- No alignment problems
- Hardware included
- Available in brushed or black finish

#### PART NO. DESCRIPTION

- BAG-6084 1973 - 2002 Chevy Truck Billet Aluminum Emergency Brake Pad - Brushed
- BAG-6088 1973 - 2002 Chevy Truck Billet Aluminum Emergency Brake Pad w/Rubber - Brushed
- XBAG-6088 1973 - 2002 Chevy Truck Billet Aluminum Emergency Brake Pad w/Rubber - Black



XBAG-6090



BAG-6090



BAG-6089



## 1962 - 1972 CHEVY II/NOVA

### THROTTLE PEDAL ASSEMBLIES AND PEDAL PADS

Direct replacement Throttle Pedal Assemblies for 1962-1972 Chevy II/Nova with ball-milled pads or rubber inserts eliminate the factory rod linkage, are designed to mount in the original firewall location and utilize a modern Lokar Throttle Cable system. The arms are splined for fine adjustment and can be switched for right and left adjustment of the throttle pad, which is spring-loaded and measures 2" x 5". Available in brushed or black finish.

For a compact and clean look, Lokar has put a modern bend on classic brake/clutch pedal pads. Our Curved Brake/Clutch Pedal Pads add style and function to your classic car. Designed with hidden screws, these pads are curved to match and bolt directly to the factory steel brake/clutch pedal. Each brake/clutch pedal pad has been fashioned after its corresponding factory rubber pad and is available in brushed or black finish.



Lokar's 1968-1972 Nova Throttle Pedal is designed to replace rod style throttle linkage only. Part Nos. BAG-6142 and XBAG-6142. To complete the installation use Lokar's Throttle Cables and Mounting Brackets.



BAG-6127

BAG-6142

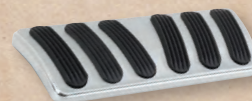

BAG-6143



XBAG-6131

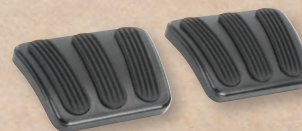

XBAG-6130 (Pair)

#### PART NO. DESCRIPTION

BAG-6126	1962-1967 Chevy II/Nova Billet Aluminum Throttle Pedal Assembly - Brushed
BAG-6127	1962-1967 Chevy II/Nova Billet Aluminum Throttle Pedal Assembly w/Rubber - Brushed
BAG-6130	1962-1972 Chevy II/Nova Billet Aluminum Curved Brake/Clutch Pad w/Rubber (Pair) - Brushed
BAG-6131	1962-1967 Chevy II/Nova Billet Aluminum Curved Automatic Brake Pad w/Rubber - Brushed
BAG-6142	1968-1972 Nova Billet Aluminum Throttle Pedal Assembly w/Rubber - Brushed
BAG-6143	1968-1972 Nova Billet Aluminum Curved Automatic Brake Pad w/Rubber - Brushed
BAG-6160	1969-1974 Nova Billet Aluminum Curved E-Brake Pad w/Rubber - Brushed
BAG-6162	1968 Nova Billet Aluminum Curved E-Brake Pad w/Rubber - Brushed
XBAG-6127	1962-1967 Chevy II/Nova Billet Aluminum Throttle Pedal Assembly w/Rubber - Black
XBAG-6130	1962-1972 Chevy II/Nova Billet Aluminum Curved Brake/Clutch Pad w/Rubber (Pair) - Black
XBAG-6131	1962-1967 Chevy II/Nova Billet Aluminum Curved Automatic Brake Pad w/Rubber - Black
XBAG-6142	1968-1972 Nova Billet Aluminum Throttle Pedal Assembly w/Rubber - Black
XBAG-6143	1968-1972 Nova Billet Aluminum Curved Automatic Brake Pad w/Rubber - Black
XBAG-6160	1969-1974 Nova Billet Aluminum Curved E-Brake Pad w/Rubber - Black
XBAG-6162	1968 Nova Billet Aluminum Curved E-Brake Pad w/Rubber - Black

## 1958 - 1962 CORVETTE BRAKE/CLUTCH PADS

1958 - 1962 Corvette billet aluminum Curved Brake/Clutch Cover is machined to fit over the stock Corvette steel brake/clutch pads. Available in brushed or black finish.

#### FEATURES

- Replaces factory rubber pad
- Quick and easy installation
- No alignment problems
- Hardware included

#### PART NO. DESCRIPTION

BAG-6110	1958-1962 Corvette Billet Aluminum Brake/Clutch w/Rubber - Brushed
BAG-6136	1958-1962 Corvette Billet Aluminum Curved Brake/Clutch Pad w/Rubber (Pair) - Brushed
XBAG-6110	1958-1962 Corvette Billet Aluminum Brake/Clutch w/Rubber - Black
XBAG-6136	1958-1962 Corvette Billet Aluminum Curved Brake/Clutch Pad w/Rubber (Pair) - Black



BAG-6136 (Pair)



XBAG-6136 (Pair)



FMG-6098  
(Recommended  
Throttle)  
See Page 54

XFMG-6098  
(Recommended  
Throttle)  
See Page 54



XBAG-6141



XBAG-6140  
(Pair)



BAG-6141

## 1958 - 1965 FULL SIZE CHEVY CURVED BRAKE & CLUTCH PADS

For a compact and clean look, Lokar has put a modern bend on classic brake pedal pads. Our Curved Brake/Clutch Pedal Pads add style and function to your classic car. Designed with hidden screws, these pads are curved to match and bolt directly to the factory steel brake/clutch pedal. Each brake/clutch pedal pad has been fashioned after its corresponding factory rubber pad and is available in brushed or black finish. 1958-1965 Pedal Pads are available for Automatic Brake and Brake/Clutch.

#### PART NO. DESCRIPTION

BAG-6140	1958-1965 Chevy Billet Aluminum Curved Manual Brake/Clutch Pad w/Rubber (Pair) - Brushed
XBAG-6140	1958-1965 Chevy Billet Aluminum Curved Manual Brake/Clutch Pad w/Rubber (Pair) - Black
BAG-6141	1958-1965 Chevy Billet Aluminum Curved Automatic Brake w/Rubber - Brushed
XBAG-6141	1958-1965 Chevy Billet Aluminum Curved Automatic Brake w/Rubber - Black



## 1967 - 1969 DART/CUDA COMPETITOR SERIES THROTTLE ASSEMBLIES & PEDAL PADS

Lokar's Competitor Series Throttle Assemblies are designed with a unique internal spanner nut ensuring perfect pedal tension. This pedal is in a class of its own; by adding this built in tensioning feature, we have eliminated the possibility of excess 'slop' in the throttle pedal.

Another milestone of the Competitor Series Throttle Pedal is its incredibly sturdy mounting base. The design of this pedal has enabled us to provide over an inch and a quarter wide mounting base yet maintain a narrow and sleek appearance. If that weren't enough, the mounting base is mounted to a thick steel plate allowing the pedal to be installed in the vehicle using the factory mounting locations without any drilling or modification. This is incredibly accommodating when installing the pedal in a vehicle which has already been painted.

In our everlasting quest for perfection, we have also built the Competitor Series Throttle Assemblies with our exclusive large diameter 3/4" x 48 tooth fine-spline steel insert to provide ultimate strength and durability.

All of these features coupled with a spring-loaded throttle pad, Delrin® bushings, and superior design have made the Competitor Series Throttle Pedal the finest and most versatile throttle pedal available.

For a compact and clean look, Lokar has put a modern bend on classic brake/clutch pedal pads. Our Curved Brake/Clutch Pedal Pads add style and function

to your classic car. Designed with hidden screws, these pads are curved to match and bolt directly to the factory steel brake/clutch pedal. Each brake/clutch pedal pad has been fashioned after its corresponding factory rubber pad and is available in brushed or black finish.

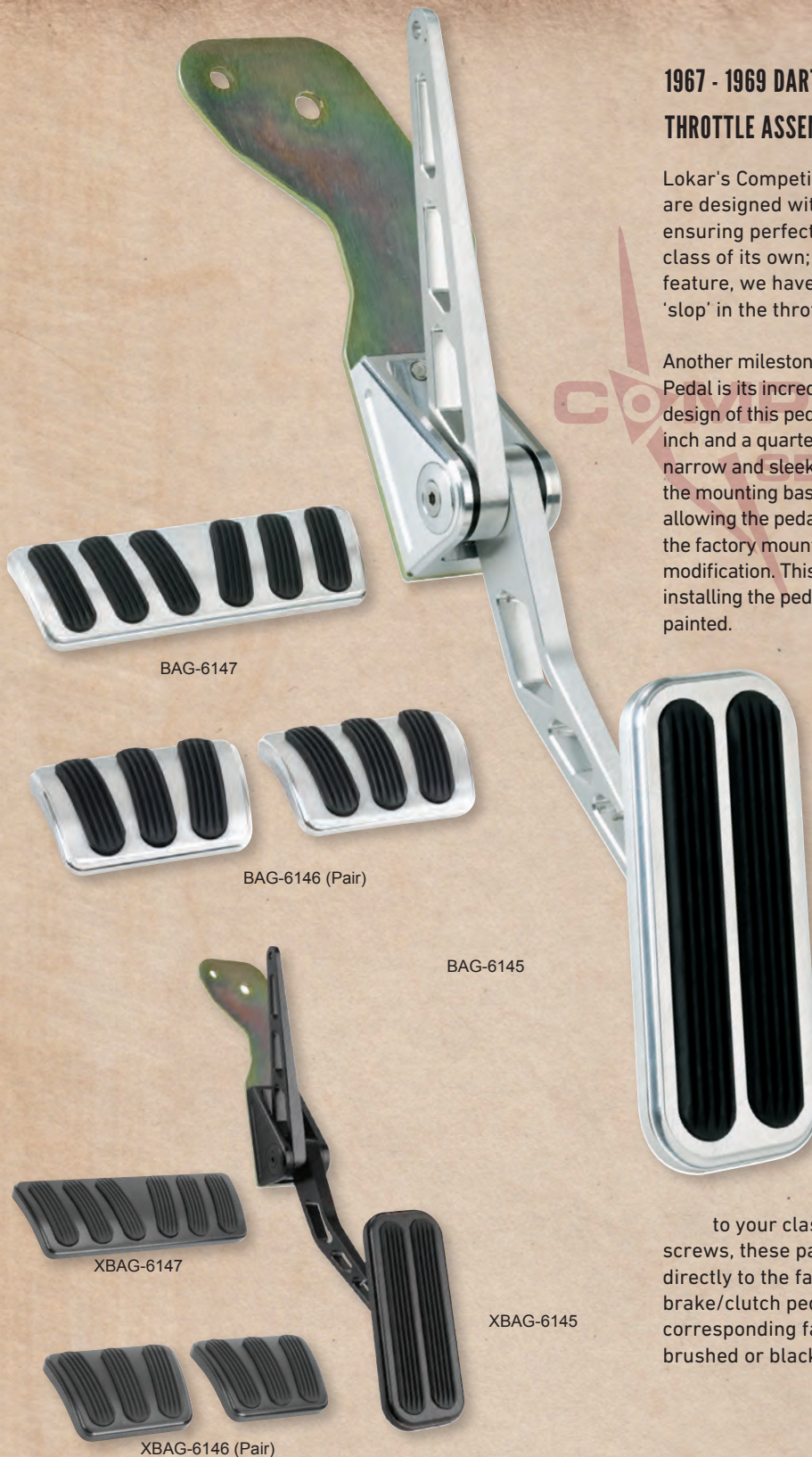

PART NO.	DESCRIPTION
BAG-6145	1967 - 1969 Dart/Cuda Billet Aluminum Throttle Assembly w/Rubber - Brushed
XBAG-6145	1967 - 1969 Dart/Cuda Billet Aluminum Throttle Assembly w/Rubber - Black
BAG-6146	1967 - 1969 Dart/Cuda Billet Aluminum Curved Brake/Clutch Pad w/Rubber (Pair) - Brushed
XBAG-6146	1967 - 1969 Dart/Cuda Billet Aluminum Curved Brake/Clutch Pad w/Rubber (Pair) - Black
BAG-6147	1967 - 1969 Dart/Cuda Billet Aluminum Curved Automatic Brake Pad w/Rubber - Brushed
XBAG-6147	1967 - 1969 Dart/Cuda Billet Aluminum Curved Automatic Brake Pad w/Rubber - Black
BAG-6178	1967 - 1976 Billet Aluminum Throttle Pedal Assembly w/Rubber Fits Dart, Demon, Duster, Valiant, Scamp - Brushed
XBAG-6178	1967 - 1976 Billet Aluminum Throttle Pedal Assembly w/Rubber Fits Dart, Demon, Duster, Valiant, Scamp - Black
BAG-6179	1967 - 1976 Billet Aluminum Curved Brake/Clutch Pad w/Rubber (Pair) Fits Dart, Demon, Duster, Valiant, Scamp - Brushed
XBAG-6179	1967 - 1976 Billet Aluminum Curved Brake/Clutch Pad w/Rubber (Pair) Fits Dart, Demon, Duster, Valiant, Scamp - Black
BAG-6180	1967 - 1976 Billet Aluminum Curved Automatic Brake Pad w/Rubber Fits Dart, Demon, Duster, Valiant, Scamp - Brushed
XBAG-6180	1967 - 1976 Billet Aluminum Curved Automatic Brake Pad w/Rubber Fits Dart, Demon, Duster, Valiant, Scamp - Black



## 1964 - 1970 MUSTANG THROTTLE PEDAL ASSEMBLIES & PEDAL PADS

Replace your worn out Mustang hard throttle linkage and pedal pads with Lokar's Mustang Throttle Assembly and Pedal Pads. Designed as a direct replacement for the stock assembly when paired with Lokar Throttle Cable and Brackets. Throw away your old stock hard linkages and get a high quality look that functions smoothly.

### FEATURES:

- 6061-T6 Aluminum
- CNC machined for looks and durability
- Direct replacement for stock assemblies
- Spring-loaded Throttle Pedal
- Delrin® bushings for smooth pedal movement
- Rubber inserts on all pads for traction
- 3M black adhesive included for installing rubber inserts
- Easy to install with basic hand tools
- Available in brushed or black finish

### BENEFITS:

- Throttle Pedal is a direct fit in OEM firewall location for easy installation
- Use with Lokar Teflon®-lined Throttle and Kickdown Cables for complete conversion
- Provides ability to change from hard linkage to cable linkage
- Conversion to Lokar assemblies makes EFI swaps a breeze
- Improves adjustment capabilities when using an AOD transmission



BAG-6117 1969 - 1970 Mounting



Engine compartment side of bracket



BAG-6123



BAG-6121 (Pair)



BAG-6115



XBAG-6123

XBAG-6121 (Pair)

XBAG-6115

PART NO.	DESCRIPTION
BAG-6115	1964-1968 Mustang Billet Aluminum Throttle Pedal w/Rubber - Brushed
BAG-6117	1969-1970 Mustang Billet Aluminum Throttle Pedal w/Rubber - Brushed
BAG-6121	1964-1970 Mustang Billet Aluminum Brake/Clutch Pad Manual w/Rubber (Pair) - Brushed
BAG-6123	1964-1968 Mustang Billet Aluminum Automatic Brake Pad w/Rubber - Brushed
BAG-6125	1969-1970 Mustang Billet Aluminum Automatic Brake Pad w/Rubber - Brushed
XBAG-6115	1964-1968 Mustang Billet Aluminum Throttle Pedal w/Rubber - Black
XBAG-6117	1969-1970 Mustang Billet Aluminum Throttle Pedal w/Rubber - Black
XBAG-6121	1964-1970 Mustang Billet Aluminum Brake/Clutch Pad Manual w/Rubber (Pair) - Black
XBAG-6123	1964-1968 Mustang Billet Aluminum Automatic Brake Pad w/Rubber - Black
XBAG-6125	1969-1970 Mustang Billet Aluminum Automatic Brake Pad w/Rubber - Black



## EARLY FORD BRONCO THROTTLE PEDAL AND BRAKE/CLUTCH PADS

**PART NO.**      **DESCRIPTION**

- BAG-6181 1966-1977 Bronco Billet Aluminum Curved E-Brake Pad with Rubber
- BAG-6182 1966-1977 Bronco Billet Aluminum Throttle Pedal Pad with Rubber
- BAG-6183 1973-1977 Bronco Billet Aluminum Curved Automatic Non Power Brake Pad w/Rubber
- BAG-6184 1976-1977 Bronco Billet Aluminum Curved Automatic Power Brake Pad with Rubber
- BAG-6185 1976-1977 Bronco Billet Aluminum Curved Brake/Clutch Pad with Rubber-Pair
- BAG-6186 1966-1977 Bronco Billet Aluminum Curved Automatic XL Non Power Brake Pad with Rubber
- XBAG-6181 Black 1966-1977 Bronco Billet Aluminum Curved E-Brake Pad with Rubber
- XBAG-6182 Black 1966-1977 Bronco Billet Aluminum Throttle Pedal Pad with Rubber
- XBAG-6183 Black 1973-1977 Bronco Billet Aluminum Curved Automatic Non Power Brake Pad with Rubber
- XBAG-6184 Black 1976-1977 Bronco Billet Aluminum Curved Automatic Power Brake Pad with Rubber
- XBAG-6185 Black 1976-1977 Bronco Billet Aluminum Curved Brake/Clutch Pad with Rubber-Pair
- XBAG-6186 Black 1966-1977 Bronco Billet Aluminum Curved Automatic XL Non Power Brake Pad with Rubber



BAG-6184  
BAG-6186



BAG-6181

BAG-6182



BAG-6185 (Pair)



XBAG-6184  
XBAG-6186



XBAG-6181



XBAG-6182



XBAG-6185  
(Pair)

## BILLET ALUMINUM DIRECT FIT JEEP THROTTLE PEDAL ASSEMBLIES AND PEDAL PADS



BAG-6175



BAG-6176



BAG-6173



XBAG-6173



XBAG-6175



XBAG-6174  
(Pair)

XBAG-6176



BAG-6174 (Pair)

**PART NO.**      **DESCRIPTION**

- BAG-6173 1976-2006 Billet Aluminum Jeep Throttle Pedal Pad w/Rubber Fits CJ-5, CJ-7, CJ-8, Scrambler, Wrangler, YJ, TJ Unlimited, Cherokee, XJ
- BAG-6174 1946-2010 Jeep, Wrangler, JK, JK Unlimited, CJ, Scrambler, YJ, TJ, & XJ Cherokee Curved Clutch & Brake Pad w/Rubber
- BAG-6175 1984-1996 Jeep Cherokee Automatic Curved Brake Pad w/Rubber
- BAG-6176 1997-2001 Jeep Cherokee Automatic Curved Brake Pad w/Rubber
- XBAG-6173 1976-2006 Billet Aluminum Jeep Throttle Pedal Pad w/Rubber Fits CJ-5, CJ-7, CJ-8, Scrambler, Wrangler, YJ, TJ Unlimited, Cherokee, XJ - Black
- XBAG-6174 1946-2010 Jeep, Wrangler, CJ, YJ, TJ, XJ Unlimited, Scrambler & Cherokee Curved Clutch & Brake Pad w/Rubber - Black
- XBAG-6175 1984-1996 Jeep Cherokee Automatic Curved Brake Pad w/Rubber - Black
- XBAG-6176 1997-2001 Jeep Cherokee Automatic Curved Brake Pad w/Rubber - Black



# Transmission Dipsticks

## HI-TECH FLEXIBLE BRAIDED STAINLESS TRANSMISSION DIPSTICKS

You have flexibility with our Teflon®-lined Flexible Braided Stainless. Transmission Dipstick. Kit comes complete with braided stainless outer housing and heat resistant E-Z to read flexible inner dipstick measuring cable. Inner cable is molded with appropriate trans fluid levels. Billet aluminum handle and billet aluminum fittings complement Lokar's Flexible Engine Dipsticks. Kit includes dipstick funnel adapter to assist in filling. Designed for "push in" style transmissions. Dipstick seals with double O-rings. Applications available for GM, Ford and Chrysler in both firewall mount and transmount. Firewall mount measures 24" in length.

Transmount mounts to the bell housing and the length varies according to the transmission application. Kit comes complete with installation instructions. Call for information on custom lengths and applications. C4 Pan is screw in style. Firewall Mount Dipsticks also available in 36" and 48" lengths.



Order additional or replacement Funnel Adapter using part # S-3026



Funnel Adapter assists in filling transmission fluid (Included)



E-Z to Read Inner Cable



Versatile firewall mount can be mounted on firewall or anywhere in engine compartment

### Firewall Mount Dipsticks

TRANSMISSION	STAINLESS STEEL	BLACK STAINLESS STEEL
GM TH350	TD-3350400FM	XTD-3350400FM
GM TH400	TD-3350400FM	XTD-3350400FM
GM Powerglide	TD-30PGFM	XTD-30PGFM
GM 700-R4	TD-3700FM	XTD-3700FM
GM TH200	TD-3200FM	XTD-3200FM
GM 200-4R	TD-3200RFM	XTD-3200RFM
GM 4L60	TD-34L60FM	XTD-34L60FM
GM 4L60E/4L65E/4L70E	TD-34L60EFM	XTD-34L60EFM
GM 4L80E	TD-34L80FM	XTD-34L80FM
GM 6L80E/6L90E	TD-36L80FM	XTD-36L80FM
FORD C4	TD-30C4FM	XTD-30C4FM
FORD C4 PAN	TD-30C4FMPAN	XTD-30C4FMPAN
FORD C6	TD-30C6FM	XTD-30C6FM
FORD FMX	TD-3FMXFM	XTD-3FMXFM
FORD AOD/4R70W/AODE	TD-3AODFM	XTD-3AODFM
CHRYSLER 727	TD-3727FM	XTD-3727FM
CHRYSLER 904	TD-3904FM	XTD-3904FM
CHRYSLER 518	TD-3518FM	XTD-3518FM
CHRYSLER 45RFE	TD-345RFEFM	XTD-345RFEFM

### Transmount Dipsticks

TRANSMISSION	STAINLESS STEEL	BLACK STAINLESS STEEL
GM TH350	TD-3350TM	XTD-3350TM
GM TH400	TD-3400TM	XTD-3400TM
GM Powerglide	TD-30PGTM	XTD-30PGTM
GM 700-R4	TD-3700TM	XTD-3700TM
GM TH200	TD-3200TM	XTD-3200TM
GM 200-4R	TD-3200RTM	XTD-3200RTM
GM 4L60	TD-34L60TM	XTD-34L60TM
GM 4L60E/4L65E/4L70E	TD-34L60ETM	XTD-34L60ETM
GM 4L80E	TD-34L80TM	XTD-34L80TM
GM 6L80E/6L90E	TD-36L80TM	XTD-36L80TM
FORD C4	TD-30C4TM	XTD-30C4TM
FORD C4 PAN	TD-30C4TMPAN	XTD-30C4TMPAN
FORD C6	TD-30C6TM	XTD-30C6TM
FORD FMX	TD-3FMXTM	XTD-3FMXTM
FORD AOD/4R70W/AODE	TD-3AODTM	XTD-3AODTM
CHRYSLER 727	TD-3727TM	XTD-3727TM
CHRYSLER 904	TD-3904TM	XTD-3904TM
CHRYSLER 518	TD-3518TM	XTD-3518TM
CHRYSLER 45RFE	TD-345RFETM	XTD-345RFETM



Firewall mount recommended for full fendered cars and trucks. Special lengths available upon request.



Firewall mount can be mounted anywhere you desire under the hood such as the firewall or inner fender apron, etc. All firewall mount dipsticks are 24" in length.

Double O-Rings for Secure Seal

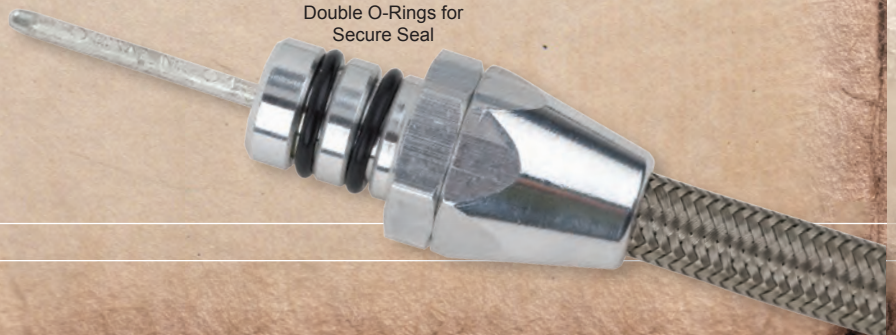



# ANCHOR-TIGHT® LOCKING FLEXIBLE TRANSMISSION DIPSTICKS



**NHRA accepted for use in all categories of competition!**

Available in Brite or Black Anodized

U.S. Patent No. 7,546,693

Flexible Dipstick with Firewall Mount Bracket

## FEATURES

- No filler tube needed
- Locking mechanism prevents expulsion of dipstick handle under trans pressure
- Bolted in sealed pan fitting to prevent expulsion of dipstick under trans pressure
- Large filler tube accepts standard transmission funnels
- Made from 6061-T6 aluminum
- Teflon®-lined stainless braided outer housing
- Flexible inner dipstick measuring cable
- No pan fitting leaks during storage
- Dipsticks available with firewall mount or transmount mounting bracket
- Trans & Firewall Mount styles supplied with trans storage plug for quick change & storage
- Spare trans fittings available for quick transmission changes
- Available for most GM, Ford and Chrysler transmissions
- Available in brite or black, and Black Stainless Steel (All Black)

REFER TO CHART ON NEXT PAGE FOR PART NUMBERS



Direct Mount

3" Direct Mount



Transmission Dipsticks



# ANCHOR-TIGHT® LOCKING FLEXIBLE TRANSMISSION DIPSTICKS



**NHRA accepted for use in all categories of competition!**

Transmission	Style	Brite Part No.	Black Part No.	All Black Part No.
Powerglide OEM & Aftermarket	3" Direct Mount	1209124	1209127	X1209127
Powerglide OEM & Aftermarket	Transmount	1210134	1210137	X1210137
Powerglide OEM & Aftermarket	Firewall Mount	1210144	1210147	X1210147
Powerglide OEM & Aftermarket	Bottom Fitting Assembly for Spare Trans	1208114	1208117	X1208117
TH350/400	3" Direct Mount	1209144	1209147	X1209147
TH350	Transmount	1211134	1211137	X1211137
TH350/400	Firewall Mount	1211144	1211147	X1211147
TH400	Transmount	1213134	1213137	X1213137
TH350/400	Bottom Fitting Assembly for Spare Trans	1208144	1208147	X1208147
700-R4	3" Direct Mount	1209154	1209157	X1209157
700-R4	Transmount	1211234	1211237	X1211237
700-R4	Firewall Mount	1211244	1211247	X1211247
700-R4	Bottom Fitting Assembly for Spare Trans	1208134	1208137	X1208137
TH200	3" Direct Mount	1209164	1209167	X1209167
TH200	Transmount	1211334	1211337	X1211337
TH200	Firewall Mount	1211344	1211347	X1211347
TH200	Bottom Fitting Assembly for Spare Trans	1208164	1208167	X1208167
Chrysler 727/904/518	Direct Mount	1209174	1209177	X1209177
Chrysler 727	Transmount	1211434	1211437	X1211437
Chrysler 727/904/518	Firewall Mount	1211444	1211447	X1211447
Chrysler 727/904/518	Bottom Fitting Assembly for Spare Trans	1208174	1208177	X1208177
All Anchor Tight Dipsticks	Storage Plug*	RP189	N/A	N/A
200-4R	3" Direct Mount	1209184	1209187	X1209187
200-4R	Transmount	1211734	1211737	X1211737
200-4R	Firewall Mount	1211744	1211747	X1211747
AOD/AODE-4R70W	Direct Mount	1209214	1209217	X1209217
AOD/AODE-4R70W	Transmount	1211834	1211837	X1211837
AOD/AODE-4R70W	Firewall Mount	1211844	1211847	X1211847
AOD/AODE-4R70W	Bottom Fitting Assembly Spare Trans	1208194	1208197	X1208197
C4	Direct Mount	1209194	1209197	X1209197
C4	Firewall Mount	1211644	1211647	X1211647
C4/C6	Bottom Fitting Assembly Spare Trans	1208184	1208187	X1208187
C6	Direct Mount	1209134	1209137	X1209137
C6	Firewall Mount	1211544	1211547	X1211547

\*Plug available in Brite finish only

Trans storage plug supplied with trans mount and firewall mount.



Firewall mount can be mounted anywhere you desire under the hood such as the firewall or inner fender apron, etc. All firewall mount dipsticks are 26" in length.





# Engine Dipsticks

## FLEXIBLE ENGINE DIPSTICKS

Flexible Engine Dipstick designed with billet aluminum handle to coordinate with Lokar's Flexible Transmission Dipstick. Slim design allows mounting inside headers. Designed for use with factory or block hugger headers. Applications available for GM, Ford and Chrysler. E-Z read flexible inner dipstick measuring cable for accurate measure of engine oil.



1980 & later Small Block Chevy ED-5001 and GM Vortec Ram Jet 350 ED-5009



Early 289-302 Ford ED-5010



1979 & earlier Small Block Chevy ED-5002



Some after-market oil pans may require a custom-made dipstick.



Small Block Chevy 1979 & earlier is on the driver's side. Small Block Chevy 1980 & later is on the passenger side.

ENGINE MAKE	YEAR/STYLE	STAINLESS STEEL	BLACK STAINLESS
Small Block Chevy	1980 & Later/Push into Block Passenger's Side	ED-5001	XED-5001
Small Block Chevy	1979 & Earlier/Push into Block Driver's Side	ED-5002	XED-5002
302 Ford	1986 to 1995 5.0/Push into Block Driver's Side	ED-5004	XED-5004
351W Ford	NA/Screw into Pan Style 5/8"-18	ED-5005	XED-5005
Chevy II	1962-1967 283/327/Front Sump	ED-5007	XED-5007
GM LS1	1997 & Later (Car)	ED-5008	XED-5008
GM Vortec Ram Jet 350	5.7L Push into Block Passenger's Side	ED-5009	XED-5009
Early 289-302 Ford	NA/thru timing chain cover	ED-5010	XED-5010
FE Ford	NA/ Push into Block Front Sump	ED-5012	XED-5012
302 Ford	NA/Crate Engine Only - Push into Pan	ED-5013	XED-5013
4.6 Modular Ford, 2 Valve	1994 & Later/Push into Block Driver's Side	ED-5014	XED-5014
Chrysler 5.7L & 6.1L Hemi	Rear Sump Pan (Truck) Push into Block Passenger's Side	ED-5015	XED-5015
Ford Flathead V8	1937-1953 - Screw into Pan	ED-5016	XED-5016
302 Ford Roush	1/4" NPT pan gauge to fit	ED-5017	XED-5017
Dart Small Block Chevy	SHP (Special High Performance Block)	ED-5018	XED-5018
LS Series	1999 & Later Truck	ED-5019	XED-5019
LS Series	1997 & Later Car with Doug Thorley Tri-Y Headers	ED-5020	XED-5020
LS Series	1999 & Later Truck with Doug Thorley Tri-Y Headers	ED-5021	XED-5021
Chrysler 5.7L & 6.1L Hemi	Front Sump Pan (Car) Push into Pan Passenger's Side	ED-5022	XED-5022
351 Cleveland Ford	1969-1974 (US), 1971-1984 (302-351 Australia)	ED-5023	XED-5023
253-308 Holden	1968-1984 (Australia)	ED-5024	XED-5024
Big Block Mopar	Front Sump Only	ED-5026	XED-5026



## BIG BLOCK FLEXIBLE ENGINE DIPSTICKS

Flexible Engine Dipstick designed with billet aluminum handle to coordinate with Lokar's Flexible Transmission Dipstick. Slim design allows mounting inside headers. Designed for clearance with block hugger headers. E-Z read flexible inner dipstick measuring cable for accurate measure of engine oil level.

ENGINE MAKE	STAINLESS STEEL	BLACK SS
Chevy Big Block	ED-5003	XED-5003
Chevy Big Block 502	ED-5006	XED-5006
Ford Big Block 460 & 514	ED-5011 (Crate Motors Only)	XED-5011
Mopar Big Block, front sump only	ED-5026	XED-5026

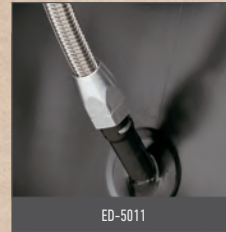

ED-5011

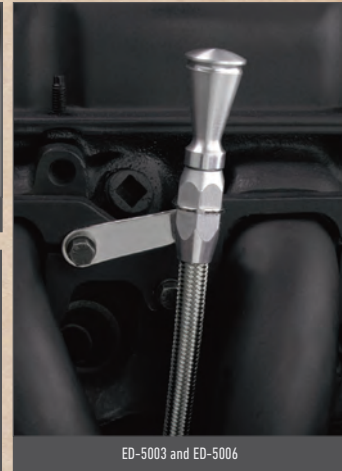

ED-5003 and ED-5006

ED-5001 & ED-5009 1220001 through 1220007 1220081 through 1220087	ED-5002 1220011 through 1220017	ED-5003 & ED-5006 1220021 through 1220027 1220051 through 1220057	ED-5004 1220031 through 1220037	ED-5005 1220041 through 1220047	ED-5007 1220061 through 1220067	ED-5008, ED-5019, ED-5020, & ED-5021 1220071 through 1220077	ED-5010 1220091 through 1220097		
ED-5011 1220101 through 1220107	ED-5012 1220111 through 1220117	ED-5013 1220121 through 1220127	ED-5014 1220131 through 1220137	ED-5015 1220141 through 1220147	ED-5016 1220151 through 1220157	ED-5017 1220171 through 1220177	ED-5018 1220181 through 1220187	ED-5023 1220251 through 1220257	ED-5026 1220261 through 1220267



**ORDERING TIP**

1220--- Part Numbers ending in '4' is brite; 7 is black.



ED-5000ESB



XED-5000ESB

### SMALL BLOCK CHEVY ENGINE DIPSTICKS

Billet aluminum and stainless Dipstick for pre-1980 Small Block Chevy. Application is straight into the engine block – no upper tube necessary. Dipstick seals at bottom of handle with double O-rings. Billet aluminum handle designed to coordinate with Lokar Flexible Transmission Dipstick.

ENGINE MAKE	YEAR	HI-TECH	BLACK
Small Block Chevy	1979 & Earlier (No Upper Tube)	ED-5000ESB	XED-5000ESB

## BILLET ALUMINUM DIRECT MOUNT LS SERIES AND FORD COYOTE GAUGE TO FIT ENGINE DIPSTICKS

With its billet aluminum handle and E-Z read flexible inner cable, Lokar's Billet Aluminum Direct Mount LS Series and Coyote Gauge to Fit Engine Dipsticks are ideal replacements for factory dipsticks and handles. Designed to mount directly into the factory dipstick tube, the Direct Mount LS Series and Coyote Gauge to Fit Engine Dipsticks feature billet aluminum handles and a U-Cut-To-Fit, E-Z read flexible inner cables for accurate engine oil measurement.

ENGINE MAKE	HI-TECH	BLACK
LS Series Engine	ED-5000LS1	XED-5000LS1
Ford Coyote Engine	ED-5000COY	XED-5000COY





## ANCHOR-TIGHT® LOCKING FLEXIBLE ENGINE DIPSTICKS



**NHRA accepted for use in all categories of competition!**

- Locking mechanism prevents expulsion of dipstick handle under pressure
- Holds vacuum
- Teflon®-lined stainless braided outer housing
- E-Z to read flexible inner dipstick measuring cable
- Available for most engine applications
- Available in brite or black anodized, and Black Stainless Steel (All Black)



U.S. Patent No. 7,779,555



Most aftermarket custom pans utilize a 1/4" NPT fitting for dipstick. Use Lokar Universal Dipstick for these applications.

### APPLICATION CHART

ENGINE	YEAR	STYLE	BRITE PART NO.	BLACK PART NO.	ALL BLACK PART NO.
Chevy 502 Big Block	N/A	Push into Pan	1220054	1220057	X1220057
Chevy Big Block	N/A	Push into Pan	1220024	1220027	X1220027
Chevy II V-8 283/327 Front Sump	1962 thru 1967	Push into Pan Passenger's side	1220064	1220067	X1220067
Chevy Small Block	1980 & Later	Push into Block Passenger's side	1220004	1220007	X1220007
Chevy Small Block	1979 & Earlier	Push into Block Driver's side	1220014	1220017	X1220017
Chevy Small Block Ram Jet 350	N/A	Push into Block Passenger's side	1220084	1220087	X1220087
Chrysler 5.7L & 6.1L Hemi	N/A	Rear Sump Pan (Truck) Push into Block Passenger's Side	1220144	1220147	X1220147
Ford 302	N/A	Crate Only Push into Pan	1220124	1220127	X1220127
Ford 302 5.0L	1986 thru 1995	Push into Block Driver's side	1220034	1220037	X1220037
Ford 351W	N/A	Screw into Pan 5/8"-18	1220044	1220047	X1220047
Ford 4.6 Modular, 2 Valve	1994 & Later	Push into Block Driver's side	1220134	1220137	X1220137
Ford Big Block 460 & 514	N/A	Crate Only Push into Pan	1220104	1220107	X1220107
Ford Early 289-302	N/A	Through Timing Chain Cover	1220094	1220097	X1220097
Ford FE	N/A	Push into Block Front Sump	1220114	1220117	X1220117
Ford V8 Flathead	1937 thru 1953	Screw into Pan	1220154	1220157	X1220157
GM LS1	1997 & Later	Push into Block Passenger's side	1220074	1220077	X1220077
GM Small Block Vortec	1996 thru 2000	5.7L Push into Block Passenger's side	1220084	1220087	X1220087
Universal	N/A	1/4" NPT Pan Fitting Gauge to Fit -12" Housing length; extra long inner rod	1220174	1220177	X1220177
Dart Small Block Chevy	N/A	Special High Performance Block	1220184	1220187	X1220187
LS Series	1999 & Later	Truck	1220214	1220217	X1220217
LS Series	1997 & Later	Car with Doug Thorley Tri-Y Headers	1220224	1220227	X1220227
LS Series	1999 & Later	Truck with Doug Thorley Tri-Y Headers	1220234	1220237	X1220237
Chrysler 5.7L & 6.1L Hemi	N/A	Front Sump Pan (Car) Push into Pan Passenger's Side	1220244	1220247	X1220247
351 Cleveland Ford	1969 thru 1984	69-74 (US), 71-84 (302-351 Australia)	1220254	1220257	X1220257
Mopar Big Block	N/A	Front Sump Only	1220264	1220267	x1220267

Engine Dipsticks



# PREMIUM BILLET ALUMINUM DIPSTICK HANDLES

Designed to fit both your flexible engine dipstick or your flexible transmission dipstick, our premium billet aluminum dipstick handles are great items to customize your engine and trans. We offer various designs including some to match the shifter knob in your vehicle. Each handle comes with two o-rings and an E-Z-Read flexible inner cable.

PART NO.	DESCRIPTION
DH-03	Premium Billet Aluminum Dipstick Handle w/ Inner Cable - 9 Ball
DH-05	Premium Billet Aluminum Dipstick Handle w/ Inner Cable - Bullet
DH-06	Premium Billet Aluminum Dipstick Handle w/ Inner Cable - Keg
DH-08	Premium Billet Aluminum Dipstick Handle w/ Inner Cable - Shifter Lever
DH-09	Premium Billet Aluminum Dipstick Handle w/ Inner Cable - Venetian
DH-10	Premium Billet Aluminum Dipstick Handle w/ Inner Cable - Deco
DH-11	Premium Billet Aluminum Dipstick Handle w/ Inner Cable - Solid Round
DH-12	Premium Billet Aluminum Dipstick Handle w/ Inner Cable - 8 Ball
DH-13	Premium Billet Aluminum Dipstick Handle w/ Inner Cable - Piston



Does not fit Anchor-Tight® Locking Dipsticks



Add 'X' before part number when ordering black anodized finish. e.g. XDH-09



Check out some of our matching shifter knobs on page 8.





# Drag Racing Products

## INTERIOR BATTERY DISCONNECT LEVER KIT



### Features

- Turn electrical power on or off from the driver's seat
- Red anodized billet aluminum power lever for quick recognition
- Works in conjunction with fire system kill switch
- **Lokar Direct-Mount™ Lever Kit** fits B&M® Pro Bandit, Quarter Pro®, Precision Performance Products Shifters
- **Lokar Vari-Mount™ Lever Kit** fits B&M® Pro Ratchet, TCI Thunder Stick™, TCI Outlaw™, TCI Lightning™ and Hurst Quarter Stick® shifters or can be mounted to the floor
- Master power switch available in 125 or 300 amp
- Kit standard with 8' push pull cable
- Push Pull Cables also available in 6' and 7'
- Mounting hardware included
- Kit available without the Master Power Switch

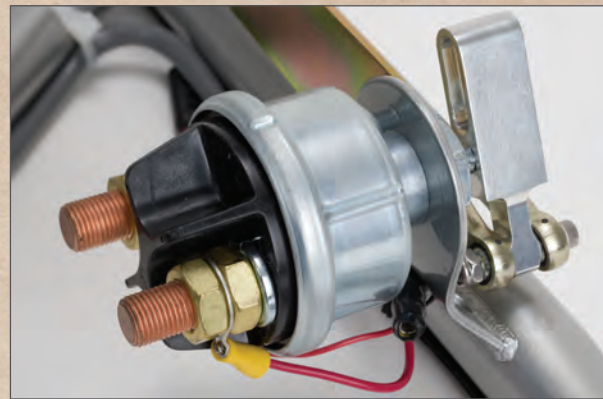
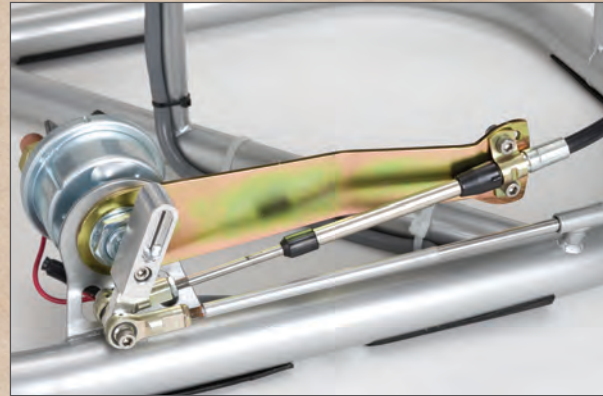

PART NO.	DESCRIPTION
1330011	Lokar Direct Mount™ Fits B&M® Pro Bandit, Quarter Pro, Precision Performance Products Shifters - 125 Amp
1330012	Lokar Direct Mount™ Fits B&M® Pro Bandit, Quarter Pro, Precision Performance Products Shifters - 300 Amp
1330013	Lokar Direct Mount™ Fits B&M® Pro Bandit, Quarter Pro, Precision Performance Products Shifters - No Switch
1330021	Lokar Vari-Mount™ Fits B&M® Pro Ratchet, TCI Thunder Stick™, TCI Outlaw™, TCI Lightning™, Hurst Quarter Stick® Shifters or can be mounted to the floor - 125 Amp Switch
1330022	Lokar Vari-Mount™ Fits B&M® Pro Ratchet, TCI Thunder Stick™, TCI Outlaw™, TCI Lightning™, Hurst Quarter Stick® Shifters or can be mounted to the floor - 300 Amp Switch
1330023	Lokar Vari-Mount™ Fits B&M® Pro Ratchet, TCI Thunder Stick™, TCI Outlaw™, TCI Lightning™, Hurst Quarter Stick® Shifters or can be mounted to the floor - No Switch







## LOKAR DIAL-IN BOARD, CAGE MOUNT AND UNIVERSAL ADJUSTABLE ANGLE MOUNT

Cage and Universal Adjustable Angle Mount Dial-In Board and Brackets are manufactured with 6061-T6 aluminum featuring a ball-milled design. Mounts onto cage without interfering with roll-bar padding. No drilling required for mounting to the cage. Bracket available for 1-1/2" cages and 1-5/8" cages. Offered in polished, black or clear finishes. Features an adjustable arm for leveling and a quickly reversible dial-in board. Also available in a universal adjustable angle mount style which can be mounted on a flat or angled surface such as a scoop tray.



Universal Adjustable Angle Mount Bracket

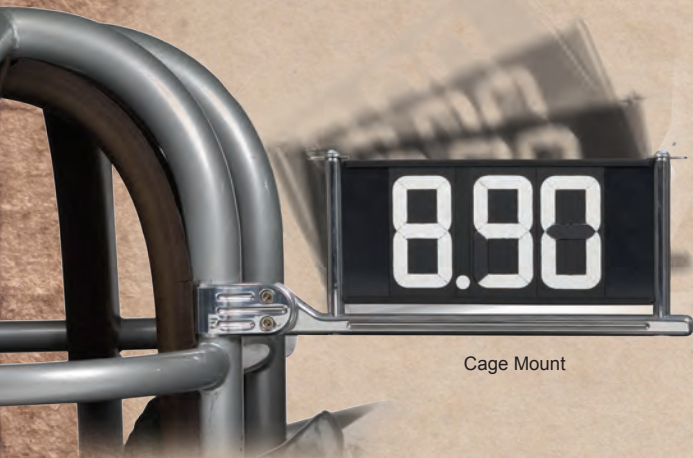

Cage Mount

PART NO.	DESCRIPTION
1110104	1.625" Dial-In Board Cage Mount - Polished
1110107	1.625" Dial-In Board Cage Mount - Black
1110108	1.625" Dial-In Board Cage Mount - Clear
1110114	1.625" Dial-In Board Cage Mount - Polished
1110117	1.625" Dial-In Board Cage Mount - Black
1110118	1.625" Dial-In Board Cage Mount - Clear
1110124	Universal Adjustable Angle Mount - Polished
1110127	Universal Adjustable Angle Mount - Black
1110128	Universal Adjustable Angle Mount - Clear
1110134	Universal Adjustable Angle Mount for MEGA Dial-In Board - Polished
1110137	Universal Adjustable Angle Mount for MEGA Dial-In Board - Black
1110138	Universal Adjustable Angle Mount for MEGA Dial-In Board - Clear
1110144	1.5" Dial-In Board Cage Mount for MEGA Dial-In Board - Polished
1110147	1.5" Dial-In Board Cage Mount for MEGA Dial-In Board - Black
1110148	1.5" Dial-In Board Cage Mount for MEGA Dial-In Board - Clear
1110164	1.625" Dial-In Board Cage Mount for MEGA Dial-In Board - Polished
1110167	1.625" Dial-In Board Cage Mount for MEGA Dial-In Board - Black
1110168	1.625" Dial-In Board Cage Mount for MEGA Dial-In Board - Clear



If you don't see your style of digital dial-in board call our tech department for support.

## BILLET ALUMINUM SAFETY LED TAILLIGHT

### Features

- 1-1/4" Billet 6061-T6 aluminum taillight housing
- Taillight housing bolts directly to Lokar Dial-In Board or can be mounted in a universal location
- Taillight wiring can be hidden in machined slot on Lokar Dial-In Board
- Colors and styles match Lokar Dial-In Boards
- Available in black, polished and clear finish
- Stainless steel mounting hardware
- Long-life LED illuminates to red for safety

PART NO.	DESCRIPTION
1110157	Billet Safety LED Taillight - Black (Compatible w/Lokar Dial-in Board)
1110158	Billet Safety LED Taillight - Clear (Compatible w/Lokar Dial-in Board)
1110154	Billet Safety LED Taillight - Polished (Compatible w/Lokar Dial-in Board)



Midnight Series™ Universal Mount



Clear LEDs illuminate to Red





## 4500/4150 SERIES CARBURETOR ROD TYPE THROTTLE LINKAGE SPRING RETURN KIT

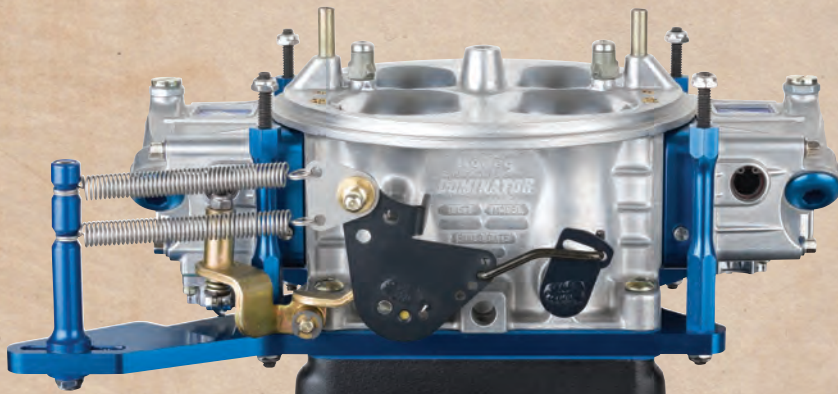

BLUE AND RED FINISH SHOWN FOR DISPLAY PURPOSES ONLY



Single Non-In-Line Cylinder Shown

### KIT INCLUDES

- Complete with two Stainless Steel Return Springs with dual wound ends for safety (eliminates single hook ends opening up)
- Adjustable spring tensioner
- Throttle Plate also drilled for scoop tray studs
- Scoop tray studs included
- Stainless hardware included
- Styles: 4 Hole Plenum

### PART NO. DESCRIPTION

PART NO.	DESCRIPTION
1010144	4500 Rod Type Throttle Linkage/Spring Return Kit 4 Hole Plenum - Brushed
1010148	4500 Rod Type Throttle Linkage/Spring Return Kit 4 Hole Plenum - Black
1010164	4150 Rod Type Throttle Linkage & Spring Return Kit 4 Hole Plenum - Brushed
1010168	4150 Rod Type Throttle Linkage & Spring Return Kit 4 Hole Plenum - Black

## 4500/4150 SERIES CARBURETOR PUSH/PULL THROTTLE CABLE MOUNTING BRACKET & SPRING RETURN KIT

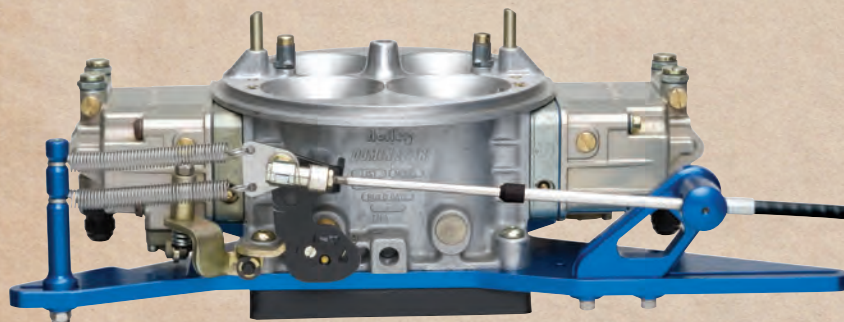

BLUE AND RED FINISH SHOWN FOR DISPLAY PURPOSES ONLY

Designed for push/pull style cables using dual cylinder in-line throttle stops or single cylinder in-line throttle stops.

### Features

- Includes two brackets to allow use of many different throttle stop styles
- Complete with two Stainless Steel Return Springs with dual wound ends for safety (eliminates single hook ends opening up)
- Adjustable Angle throttle cable mount for obtaining correct angle, creating less strain on throttle cable
- When using a throttle stop, design allows cylinders to hang below and remain in-line, eliminating typical top mount "flopping".

### PART NO. DESCRIPTION

PART NO.	DESCRIPTION
1010114	4500 Push/Pull Throttle Cable Mounting Bracket and Spring Return Kit 4 Hole Plenum - Brushed
1010118	4500 Push/Pull Throttle Cable Mounting Bracket and Spring Return Kit 4 Hole Plenum - Black
1010124	4500 Push/Pull Throttle Cable Mounting Bracket and Spring Return Kit Open Plenum - Brushed
1010128	4500 Push/Pull Throttle Cable Mounting Bracket and Spring Return Kit Open Plenum - Black
1010158	4150 Push/Pull Throttle Cable Mounting Bracket & Spring Return Kit 4 Hole Plenum- Black

BLUE AND RED FINISH SHOWN FOR DISPLAY PURPOSES ONLY



Double In-Line Shown



Push/Pull Throttle Cable Mounting Bracket & Spring Return Kit Open Plenum

### KIT INCLUDES

- Complete with two Stainless Steel Return Springs with dual wound ends for safety (eliminates single hook ends opening up)
- Adjustable spring tensioner
- Throttle Plate also drilled for scoop tray studs
- Scoop tray studs included
- Stainless hardware included
- Styles: 4 Hole Plenum  
Open Plenum (4500 Only)



# Lokar Wear

Lokar t-shirts and sweatshirts are designed for comfort and durability. It's a great way to show your support of Lokar while looking great too!



## LOKAR EQUIPPED T-SHIRT

Featuring an iconic lead sled on the back.  
Gildan DryBlend 50% cotton, 50% polyester  
Sizes: S, M, L, XL, 2XL, 3XL, 4XL  
Color: Black

## LOKAR VINTAGE PERFORMANCE T-SHIRT

Gildan DryBlend 50% cotton, 50% polyester  
Sizes: S, M, L, XL, 2XL, 3XL, 4XL  
Color: Black



Pullover

Full-zip

## LOKAR EQUIPPED HOODIE SWEATSHIRTS

Available in Pullover and Full-zip  
Gildan DryBlend 50% cotton, 50% polyester  
Sizes: S, M, L, XL, 2XL, 3XL  
Color: Black





1-877-469-7440 | [LOKAR.COM](http://LOKAR.COM) | LIFETIME WARRANTY | U.S.A. MADE