

Axle Order Form

800-772-2678 Fax 800-772-2618



BILLING ADDRESS

Name: _____

Phone: _____

Address _____

City _____ State _____ Post Code _____

SHIPPING ADDRESS (same as billing)

Name: _____

Phone: _____

Address _____

City _____ State _____ Post Code _____

ORDER DETAILS

Package # _____

Additional Parts & Options _____

AXLES The information below is required for all orders

Application street strip circle other _____

Axle Type alloy alloy (c-clip style) hy-tuf

Carrier Brand & Type (posi, spool...) _____

Brake Description (drum, disc, manufacturer...) _____

Spline Count _____ Bolt Circle _____ A _____ D _____

WHEEL STUD INFORMATION

Bolt Head Style Wheel Studs 1/2"-20 x 2"
 1/2"-20 x 3"
 5/8"-18 x 3"



Press-in Wheel Studs _____
 Thread & Length (applicable to alloy axles only)

Hole Diameter for Custom Studs _____

MEASURING PRE-EXISTING AXLES FOR UPGRADE

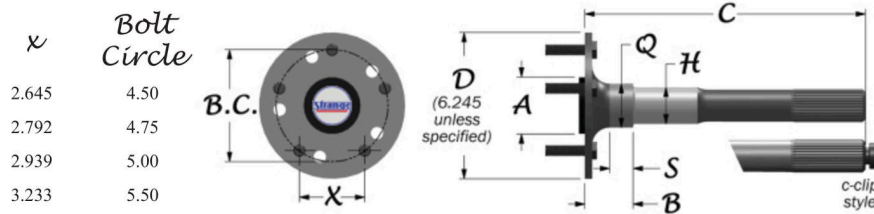

\times	Bolt Circle
2.645	4.50
2.792	4.75
2.939	5.00
3.233	5.50

DIMENSIONS

B _____

H _____

Q _____

S _____

Driver Side C _____

Passenger Side C _____

MEASURING REAR END FOR UPGRADING AXLES

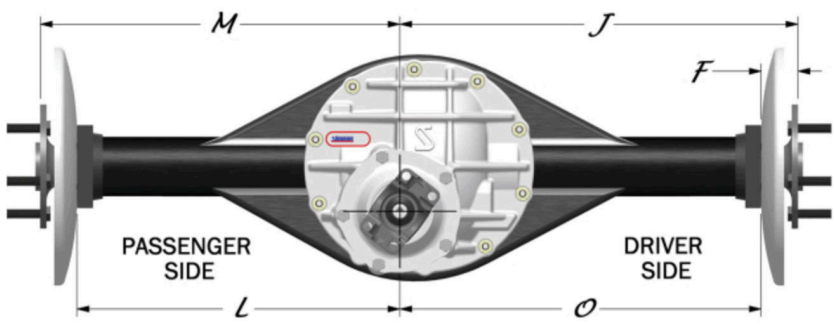

DIMENSIONS

F _____

J _____

M _____

Axle Flange to Axle Flange (J+M) _____

O _____

L _____

Housing End to Housing End (O+L) _____

INDICATE TYPE OF HOUSING END Check the corresponding box next to the housing end type

<input type="checkbox"/>	<input type="checkbox"/>	<input type="checkbox"/>	<input type="checkbox"/>	<input type="checkbox"/>	<input type="checkbox"/>	<input type="checkbox"/>
Strange Ford 8.8" H1138	Factory Ford 8.8"	Big Ford H1135	Late Big Ford H1137 H1148	Mustang H1134	Factory 05-up Mustang	Olds H1132 H1142
<input type="checkbox"/>	<input type="checkbox"/>	<input type="checkbox"/>	<input type="checkbox"/>	<input type="checkbox"/>	<input type="checkbox"/>	<input type="checkbox"/>
Strange Small GM H1143	Factory Small GM	Factory Large GM	Mopar H1133	Mopar H1147	Symmetrical H1131	Symmetrical H1136

Axle Order Form

Dimension Definitions & Common Sizes



- A** Brake Register
Centers the factory OEM brake drum or rotor and where applicable the wheels. Rotors applied in drag racing are typically centered by the wheel studs and have an oversized center allowing compatibility with various brake register sizes.
Chrysler/Dana/Mopar common *A* dimensions: 2.300 or 2.820
Ford common *A* dimensions: 2.430, 2.525, 2.750, 2.780, 2.796, 2.875 or 3.060
General Motors common *A* dimensions: 2.780, 2.812 or 3.060
- B** Bearing Shoulder
This is the bearing stop machined on the axle. This feature is not applicable to c-clip style axles. This is not identical to the *F* axle offset dimension since most axle bearings protrude from the housing end. The type of bearing, sealed ball or tapered, will result in a different axle offset using the same *B* dimension. If an original type of bearing is not used then the *B* dimension will need to be changed in order to maintain the original wheel offset.
Chrysler/Dana/Mopar common *B* dimensions: 2.200, 2.3125 or 2.5625
Ford common *B* dimensions: 1.875, 2.0625, 2.125, 2.250, 2.375, 2.4375
- C** Axle Overall Length
This dimension is taken from the outside face of the axle flange to the end of the splines. Driver side and passenger side typically have different *C* dimensions. Measurement must be precise, best accomplished by using a straight edge and tape measure. Please let us know if you have given a *C* dimension with an existing carrier and intend to change the carrier. The change may alter the *C* dimension.
- D** Axle Flange Diameter
Ø 6.245 is the Strange Engineering standard axle flange diameter unless otherwise specified. Customer must request a different size if clearance with the rotor or drum is an issue.
- F** Axle Offset (Brake Gap)
Measured from outside face of axle flange to the outside face of the housing end.
Ford common *F* dimensions: 2.145, 2.3326, 2.500, 2.625
General Motors common *F* dimension: 2.8325
- F** Axle Offset (Brake Gap) with Chrysler or Mopar Rarends
Measured from outside face of axle flange to the outside face of the housing end. On Chrysler/Dana/Mopar type housing ends, *F* is obtained with the backing plate and gasket installed or combined thickness accounted for. If aftermarket disc brakes are being used then it's best to remove the axle bearing and supply the *B* dimension to ensure proper fitment of axles.
Chrysler/Dana/Mopar common *F* dimensions: 2.3125, 2.423 or 2.673
- H** Bearing Journal Diameter
Diameter on which the axle bearing is pressed onto. Dimension is not required if purchasing bearings with axle order.
Chrysler/Dana/Mopar common *H* dimension: 1.5635
Ford common *H* dimensions: 1.379, 1.400, 1.532, 1.563, 1.626 or 1.773
General Motors common *H* dimensions: 1.379, 1.400, 1.532, 1.563, 1.626 or 1.773
- J** Distance from outside face of driver side axle flange to center of pinion
- L** Distance from outside face of passenger side housing end to center of pinion
- M** Distance from outside face of passenger side axle flange to center of pinion
- O** Distance from outside face of driver side housing end to center of pinion
- Q** Seal Journal Diameter
Diameter on which the seal rides. Only necessary if the axle requires an outer seal, but the axle bearings are not being purchased
- S** Seal Journal Width
The width of the seal journal diameter. Only necessary if the axle requires an outer seal, but bearings are not being purchased.
- X** Distance Between Centers of Wheel Studs for Calculating Bolt Circle
Measurement is taken from the center of one wheel stud to the center of the wheel stud closest to it. This dimension is used as a reference to calculate the bolt circle (B.C.)
Only applies to 5 wheel stud pattern.
This does NOT apply to a 4,6 or 8 wheel stud pattern.



OUTLAW
SPEED SHOP

www.outlawspeed.com.au

Custom Order Release

Please be advised that in placing this order for custom manufactured merchandise you are accepting full responsibility for the correctness and accuracy of all pertinent ordering information.

Further, be advised that by filling out and signing this form you are affirming the correctness and accuracy of the information contained herein and authorizing Outlaw Speed Shop to order this

custom merchandise. Once this form has been signed, the purchaser assumes full responsibility for paying for the custom merchandise and no refund will be issued unless it can be shown that any errors or defects were the fault of the manufacturer and not caused by incorrect information.

As a rule, custom orders cannot be cancelled once the order is placed with the manufacturer.

All custom orders are subject to freight and handling charges from the manufacturer.

No returns will be accepted on custom-built items.

Customer Name _____

Address _____

City _____ State _____ Post Code _____

Phone _____

Fax _____

Email _____

Print Your Name _____ Date _____

Authorized Signature _____

Outlaw Speed Shop

50 Grand Junction Rd, Rosewater, S.A, 5013

web: www.outlawspeed.com.au | phone: 08 8240 9500 | fax: 08 8240 3619